

# C-800NC

## SNC-100 Programmable Automatic Mass Production Horizontal Bandsaw

---

# Manual

*!!! We **saw** the future !!!*

# Safety rules



- It's essential to power on your bandsaw machine for at least one hour every two years, if you seldomly use the machine. (This period of power-on must be without proceeding with other operation) Otherwise the machine program may disappear due to not strictly follow this safety rule.

**\*\*The restoration-service fee for improper use will be extra charge. Please note.\*\***



- Make sure your work area is cleared of uninvited people and obstacles every time before you start operating the machine.



- Never step or stand on the roller table. Your foot may slip or trip on the rollers and you will fall.



- Never wear gloves or loose clothing when operating the machine. It may lead to serious injury if they are caught in the running machine. Wrap or cover long hair.

- Never touch the running saw blade with gloves or not. It is dangerous if your hands, clothing or gloves are caught by the running blade.



- Make sure any use of fire is prohibited in the shop and install a fire extinguisher or other fire control device near the machine when cutting titanium, magnesium, or any other material that produces flammable chips. Never leave the machine unattended when cutting flammable materials.



- Use a water-soluble cutting fluid on this machine. Oil-based cutting fluids may emit smoke or catch fire, depending on how they are used.

# Safety rules



- Never cut carbon or any other material that may produce and disperse explosive dust. It is possible that sparks from motors and other machine parts will ignite and explode the air-borne dust.



- Never adjust the wire brush or remove chips while the saw blade is still running. It is extremely dangerous if hands or clothing are caught by the running blade.

- Stop the saw blade before you clean the machine. It is dangerous if hands or clothing are caught by the running blade.

- Never start the saw blade unless the workpiece has been clamped firmly. If the workpiece is not securely clamped, it will be forced out of the vise during cutting.



- Take preventive measures when cutting thin or short pieces from the work to keep them from falling. It is dangerous if the cut pieces fall.

- Use roller tables at the front and rear sides of the machine when cutting long work. It is dangerous if the work piece falls off the machine.



- Turn off the shop circuit breaker switch before performing maintenance on the machine. Post a sign indicating the machine is under maintenance.

# Table of Contents

<b>Section 1 – Safety Information</b>	<b>1-1</b>
Safety Instructions .....	1-1
Safeguard Devices .....	1-3
<i>Illustration: Safety Fence (CE model only)</i> .....	1-4
Emergency Stop .....	1-5
<i>Illustration: Emergency Stop</i> .....	1-6
Safety Labels .....	1-7
<i>Illustration: Safety Labels</i> .....	1-10
Hearing Protection .....	1-11
CE Compliance .....	1-11
Risk Assessment .....	1-11
<b>Section 2 – General Information</b>	<b>2-1</b>
Specification .....	2-2
Machine Parts Identification .....	2-4
Floor Plan .....	2-5
<b>Section 3 – Moving &amp; Installation</b>	<b>3-1</b>
Location & Environment .....	3-1
Unpacking & Inspecting .....	3-2
Lifting .....	3-3
<i>Illustration: Lifting Points</i> .....	3-5
Removing Shipping Bracket .....	3-6
Cleaning .....	3-6
Installing .....	3-6
Supplying Hydraulic Oil .....	3-6
Supplying Coolant .....	3-7
Connecting Electric Power .....	3-7
Leveling .....	3-8
Anchoring the Machine .....	3-9
Installing Roller Table (Optional) .....	3-9
Relocating .....	3-9
<b>Section 4 – Operating Instructions</b>	<b>4-1</b>
Safety Precautions .....	4-2
Before Operating .....	4-3
Control Panel .....	4-4
Control Panel .....	4-4

# Table of Contents

Control Buttons .....	4-5
HMI Touch Screen & Functions .....	4-8
HMI Error Codes .....	4-19
Standard Accessories .....	4-20
Optional Accessories .....	4-23
Unrolling & Installing the Blade .....	4-25
Adjusting Wire Brush .....	4-27
Adjusting Saw Arm .....	4-27
Placing Workpiece onto Workbed .....	4-27
Positioning Workpiece for Cutting .....	4-28
Adjusting Blade Speed .....	4-28
Adjusting Coolant Flow .....	4-29
Breaking-In the Blade .....	4-29
Test -Running the Machine .....	4-30
Cutting Operation .....	4-30
Starting an Automatic Operation .....	4-31
Using Top Clamp for Bundle Cutting .....	4-32
Terminating a Cutting Operation .....	4-33
<b>Section 5 – Electrical System</b> .....	<b>5-1</b>
Electrical Circuit Diagrams .....	5-1
<b>Section 6 – Hydraulic System</b> .....	<b>6-1</b>
Hydraulic Diagrams .....	6-1
<b>Section 7 – Bandsaw Cutting: A Practical Guide</b> .....	<b>7-1</b>
Introduction .....	7-1
Saw Blade Selection .....	7-1
WISE LOADING .....	7-3
BladeBreak -In .....	7-3
<b>Section 8 – Maintenance &amp; Service</b> .....	<b>8-1</b>
Introduction .....	8-1
Basic Maintenance .....	8-1
Maintenance Schedule .....	8-1
Before Beginning a Day’s Work .....	8-2
After Ending a Day’s Work .....	8-2
Every 2 weeks .....	8-2
First 600hrs for new machine,then every 1200h.....	8-2

# Table of Contents

Every Six Months .....	8-3
Storage Conditions .....	8-3
Terminating the Use of Machine .....	8-3
Oil Recommendation for Maintenance .....	8-4
<b>Section 9 – Troubleshooting</b>	<b>9-1</b>
Introduction .....	9-1
Precautions .....	9-2
General Troubles & Solutions .....	9-2
Minor Troubles & Solutions .....	9-3
Motor Troubles & Solutions .....	9-3
Blade Troubles & Solutions .....	9-4
Sawing Problems & Solutions .....	9-5
Re-Adjusting the Roller Table .....	9-12
<b>Section 10 – Parts List</b>	<b>10-1</b>
Spare Parts Recommendations .....	10-1
Parts List .....	10-2

# SAFETY INFORMATION

SAFETY INSTRUCTIONS

SAFEGUARD DEVICES

EMERGENCY STOP

SAFETY LABELS

HEARING PROTECTION

CE COMPLIANCE

RISK ASSESSMENT

Safety is a combination of a well-designed machine, operator's knowledge about the machine and alertness at all times. COSEN's band machine has incorporated many safety measures during the design process and used protective devices to prevent personal injuries and potential risks. Warning labels also serve as a reminder to the operator.

Throughout this manual, you will also see various safety-related symbols indicating **important information that you should take note of prior to use of the machine or part of its functions**. These important safety instructions do not cover all possible situations that might occur. It is your responsibility to **take caution** and follow procedures stated in this manual when installing, maintaining and operating your machine. Cosen will not be liable for damages resulting from improper use.

## SAFETY INSTRUCTIONS

What the icons and signs in this user manual mean:



This icon marks **WARNING**; hazards or unsafe practices that may result in **personal injury or damage to the machine**.



Supplementary information to the procedures described in this manual.



Call your local agent or our service center for help.



This manual has important safety information. Read through it carefully before operating this machine to prevent personal injury or machine damage. Learn the operation, limitation and the specific potential hazards peculiar to this band saw. All users must read it before performing any activity on the machine, such as replacing the saw band or doing regular maintenance.



Disconnect the power cord before making adjustment, maintenance or blade changes.



Do not operate this machine unless it is completely assembled.



Make sure the power switch is off before plugging in power cord.



Always remember to switch off the machine when the work is completed.



Use recommended accessories. Improper accessories may be hazardous.



Never hold the material by hand for cutting. Always use the vise and make sure the material is clamped securely before cutting.



When a workpiece is too long or heavy, make sure it is supported with a roller table (recommended).



Keep your work area well illuminated at minimum 500 lumen.



Remove adjusting keys, wrenches or any loose parts or items from the machine before turning on power.



Use a sharp saw blade and keep the machine in its best and safest performance by following a periodical maintenance schedule.



Wear proper apparel during operation and when servicing the machine. Some personal protective equipment is required for the safe use of the machine, e.g. protection goggles.



Moving parts should be kept in proper alignment and connection with the machine. Check for breakage, mounting and any other conditions that may affect its operation. Any damaged part or guard should be properly repaired or replaced.



It is dangerous to operate the machine when the floor is slippery. Keep the floor clean and dry. Check for ice, moisture, or grease before entering.



Do not use the machine to cut explosive material or high pressure vessels as it will generate great amount of heat during the sawing process and may ignite an explosion.



Keep your work area clean. Cluttered and slippery floors invite accidents.



Keep blade protection cover and wheel covers in place and in working order.



Never operate while under the influence of drugs, alcohol or medication.



Do not reach over or stand on any part of the machine.



Keep the work environment safe. Do not use band saw in a damp or wet location.



Keep all guards and shields in place before installing or starting up the machine.



Keep unauthorized personnel away.



## SAFEGUARD DEVICES

The safeguard devices incorporated in this machine include the following two main parts:

1. Protection covers & guards
2. Safety-related switches

### **Protection Covers & Guards**

1. Idle wheel housing cover
2. Drive wheel housing cover
3. Gear reducer cover
4. Wire brush belt cover
5. Blade guard cover (left & right)
6. Safety fence (left & right)(CE model only, as shown in Illustration: *Safety Fence*)
7. Chip conveyor cover (CE model only)



The protection devices should always be mounted on the machine whenever the machine is running.



Do not remove any of these safeguard devices under any circumstances except when servicing the machine. Even skilled service technicians should still take cautions when performing repairs or service on the machine with any of these protectors removed. It is the responsibility of the user to make sure all these elements are not lost and damaged.



Take note of the following main moving parts on the machine prior to and during machine operation:

- Saw bow assembly
- Drive and idle wheels
- Blade guide arm
- Saw blade guide rollers
- Quick approach device
- Wire brush
- Chip conveyor (optional)
- Workpiece clamping vises
- Shuttle vises and workbed rollers
- Top clamps (optional)
- Gear reducer

**Illustration: Safety Fence (CE model only)**

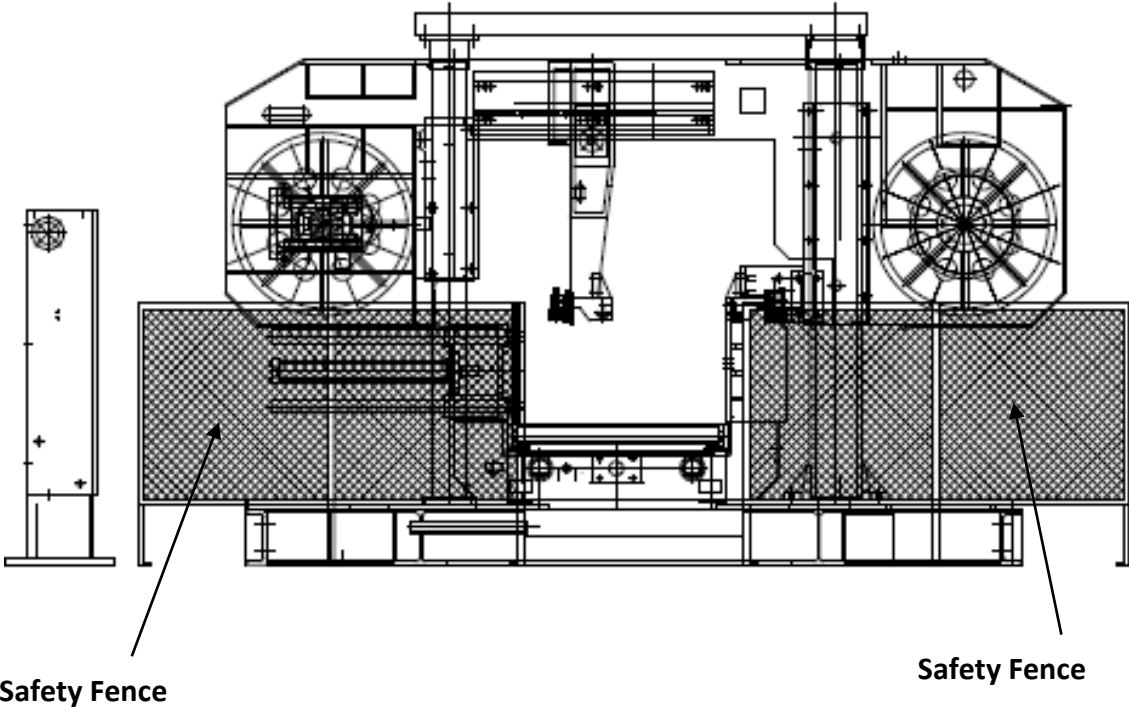

## **Safety Related Switches**

To protect the operator, the following safety related switches on the machine are actuated when the machine is in operation.

Wheel motion detector	This is a proximity sensor used to detect the motion of the drive wheel. Once the saw blade is broken <b>or as soon as it starts slipping</b> , the sensor will detect and stop the drive wheel and the machine.
Power switch	Located on the cover of electrical cabinet, the power switch controls the main power of the machine.
Emergency stop button	Located on <b>the control panel</b> , the button when pressed will stop the machine completely.
Vise clamp switch	This switch assures firm clamping of the workpiece. If the workpiece is not clamped properly, the saw blade is not allowed to run.
<b>Wheel cover interlock switches (CE model only)</b>	<b>Located on the two wheel housings, these switches are used to assure that the machine will stop whenever the wheel covers are open. This device is to protect users from being cut by the running saw blades.</b>

Among all these safety switches, some of them are used to protect the users and some of them are used to prevent damage to saw blades, the workpiece and the machine itself, etc. We have taken every precaution to prevent injury or damage and to provide safe and economical operation of the machine.

## **EMERGENCY STOP**

Designed to be easily accessible, the emergency stop button is located on the left bottom corner on the control panel and is made in red color and rubber material. **For CE models, supplementary emergency stop button may be available at other area(s) of the machine depending on machine type. Please refer to *Illustration: Emergency Stop*.**

When you press the button, the machine will immediately come to a full stop to avoid injury or damage when an accident occurs. The button will be locked when you press it. To unlock it, pull it upward.

You should press it immediately without any hesitation when observing:

- An emergency situation that would cause any injury or damage
- An abnormal situation or problem such as fire, smoke, abnormal noise and etc.

**Illustration: Emergency Stop**

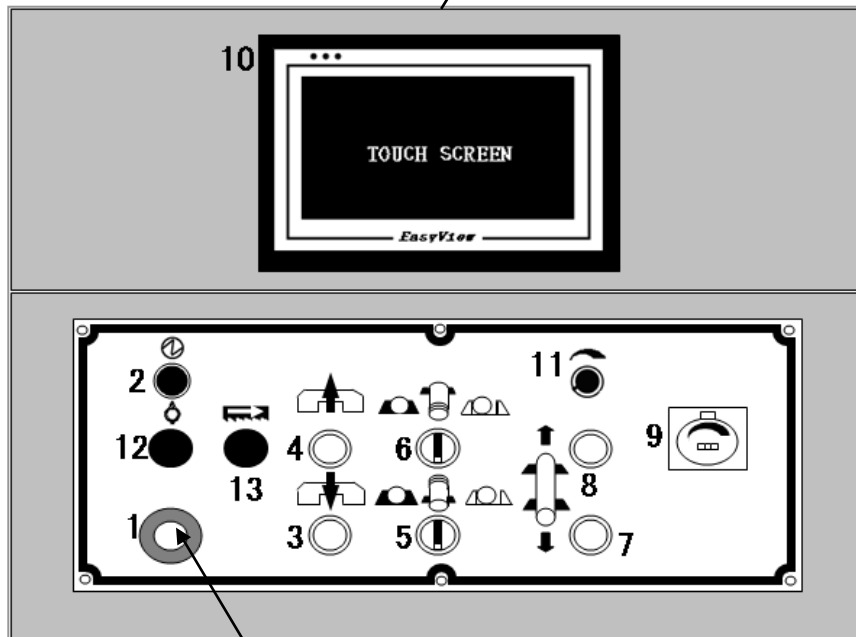
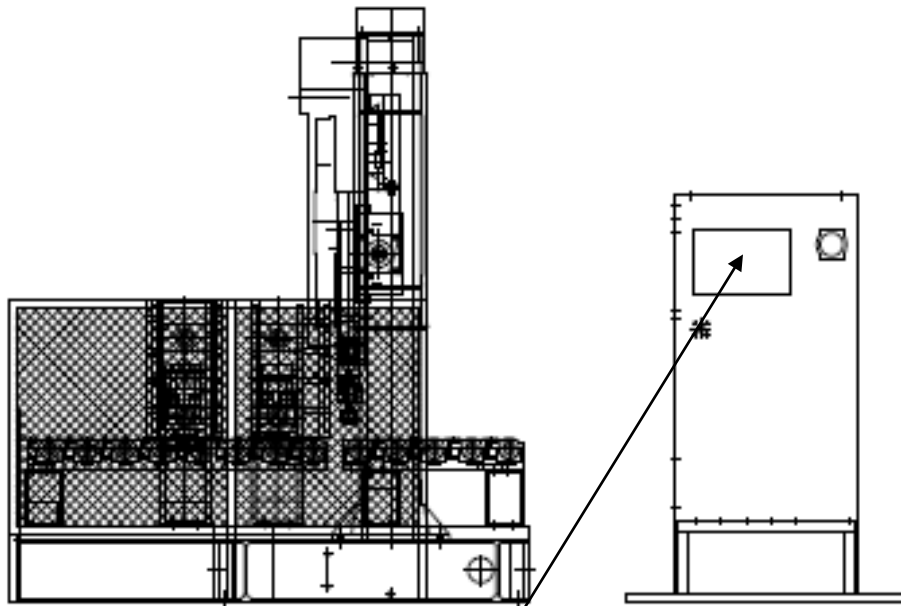

**Emergency Stop**

## SAFETY LABELS

Safety-related labels mounted on the machine are categorized into the following four categories. Please read through and understand them before operating the machine. Refer to *Illustration: Safety Labels*.

Label	Meaning	Label	Meaning
	Impact Hazard  WEAR SAFETY SHOES. Do not approach dropping area during operation.		Read Operator's Manual  This manual has important safety information. Read through it carefully before operating this machine to prevent personal injury or machine damage.
	Keep Unauthorized Personnel Away		Do not step.  Do not stand on the machine or on the accessories!
	DANGER: Running Blade  Blade runs through this area. Keep your hands away from a running blade to avoid severe injury. The arrow indicates direction of the blade.		Cutting Hazard  KEEP COVER CLOSED / KEEP HAND OFF while the blade is running. Turn power off before opening cover. Failure to follow the warning can result in severe injury.
	Hazardous Voltage  TURN POWER OFF before servicing. Failure to following the warning can result in severe injury.		Burn Hazard/Hot Surface
	Hand Crush/Force from Above		Crush hazard by vise
	Loose Hand Hazard  KEEP HAND OFF. Do not touch chip conveyor. Failure to follow the warning can result in severe injury.		Pinch Point/Hand Entanglement
	CAUTION : Class I invisible Laser Radiation Present.  Avoid direct exposure to beam.		





## DANGER Labels

A red and white DANGER labels marks hazards or unsafe practices that will result in severe personal injury or death.

Label	Meaning	Label	Meaning
	<p>Hazardous Voltage</p> <p>TURN POWER OFF before servicing. Failure to following the warning can result in severe injury.</p>		<p>DANGER: Running Blade</p> <p>Blade runs through this area. Keep your hands away from a running blade to avoid severe injury. The arrow indicates direction of the blade.</p>

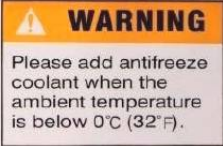

## WARNING Labels

An orange and black WARNING label marks hazards or unsafe practices that can result in severe personal injury or damage to the machine.

Label	Meaning	Label	Meaning
	<p>Cutting Hazard</p> <p>KEEP COVER CLOSED while the blade is running. Turn power off before opening cover. Failure to follow the warning can result in severe injury.</p>		<p>Cutting Hazard</p> <p>KEEP HAND OFF while the blade is running. Turn power off before opening cover. Failure to follow the warning can result in severe injury.</p>
	<p>Please add antifreeze coolant when the ambient temperature is below 0°C (32°F).</p>		<p>Loose Hand Hazard</p> <p>KEEP HAND OFF. Do not touch chip conveyor. Failure to follow the warning can result in severe injury.</p>
	<p>Impact Hazard</p> <p>WEAR SAFETY SHOES. Do not approach dropping area during operation.</p>		



## CAUTION Labels

Yellow and black CAUTION labels mark hazards or unsafe practices that can result in considerable personal injury.

Label	Meaning
	Keep hands out of the machine while the blade is running.
	Power to machine must be turned off when changing blades or adjusting wire brush.

## NOTICE Labels

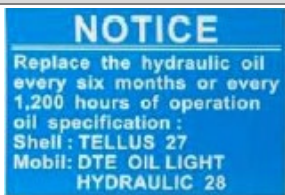
Blue and white NOTICE labels mean unsafe practices that could result in damage to products or property.

Label	Meaning
	Replace the hydraulic oil every six months or every 1,200 hours of operation.  Oil specification: Shell TELLUS 27 or Mobil DTE OIL LIGHT / HYDRAULIC 28
	To extend blade life, always adjust the location of wire brush so that it is properly touching the blade. Also replace a worn wire brush with a new one.

## **SAFETY INSTRUCTION Labels**

Green and white SAFETY INSTRUCTIONS are important reminders that should be read before operating the machine.

Label	Meaning
 <p><b>SAFETY INSTRUCTIONS</b></p> <ol style="list-style-type: none"><li>1. READ AND UNDERSTAND THE INSTRUCTION MANUAL AND WARNING SIGNS BEFORE OPERATING MACHINE. FAILURE TO FOLLOW THESE INSTRUCTIONS AND WARNINGS CAN RESULT IN SERIOUS INJURY OR DEATH.</li><li>2. Do not wear gloves, neckties, jewelry or loose clothing while operating.</li><li>3. Always wear eye protection goggle.</li><li>4. Check blade tension and adjust blade guide before starting cut.</li><li>5. Always clamp stock firmly in place before cutting and use auxiliary support for long material.</li><li>6. Do not remove jammed or cut-off pieces until blade has stopped.</li><li>7. Keep fingers out of path of blade.</li><li>8. Guards should be in place and used at all times.</li><li>9. Disconnect machine from power source before making repairs or adjustments.</li><li>10. Do not operate while under the influence of drugs, alcohol or medication.</li></ol> <p>DO NOT REMOVE OR DISFIGURE THIS SIGN</p>	<ol style="list-style-type: none"><li>1. Read and understand the instruction manual and warning signs before operating machine. Failure to follow these instructions and warnings can result in serious injury or death.</li><li>2. Do not wear gloves, neckties, jewelry or loose clothing while operating the machine.</li><li>3. Always wear eye protection goggles.</li><li>4. Check blade tension and adjust blade guide before starting to cut.</li><li>5. Always clamp stock firmly in place before cutting.</li><li>6. Do not remove jammed or cut-off pieces until blade has stopped.</li><li>7. Keep fingers out of path of blade.</li><li>8. Blade guards should be in place and used at all times.</li><li>9. Disconnect machine from power source before marking repairs or adjustments.</li><li>10. Do not operate while under the influence of drugs, alcohol or medication.</li></ol>



# Illustration: Safety Labels

C-800NC /C-1000NC

**WARNING**  
Cutting Hazard  
KEEP COVER CLOSED during sawblade running.  
Turn Power Off before opening cover.  
Failure to follow the warning can result in severe injury.

**POWER TO MACHINE MUST BE TURNED OFF WHEN CHANGING BLADES OR ADJUSTING CHIP BRUSH**

**COSEN**

**NOTICE**  
Always adjust the location of wire brush and use a new one instead of exhausted can extend the saw blade life.

**CAUTION**  
KEEP HANDS OUT OF MACHINE

**WARNING**  
Cutting Hazard  
KEEP COVER CLOSED during sawblade running.  
Turn Power Off before opening cover.  
Failure to follow the warning can result in severe injury.

**SAFETY INSTRUCTIONS**

1. READ AND UNDERSTAND THE INSTRUCTION MANUAL AND WARNINGS FROM BEFORE OPERATING MACHINES.
2. ALWAYS WEAR THE PROTECTIVE EQUIPMENT AND TOOLS. ALWAYS USE SAFETY DEVICES OR TOOLS.
3. DO NOT USE POWER, REVERSE, RESET OR HOLD CUTTING WHEN OPERATING.
4. Always wear seat belt and adjust from your vehicle cutting when operating.
5. Do not operate powered in cut of power and brake cutting off.
6. Do not adjust blade being in place before cutting and use auxiliary support to long material.
7. Do not adjust pressure in cut of power and brake cutting off.
8. Always keep out of path of blade.
9. Handle should be a place and end of all lines.
10. Disconnect auxiliary from ground before making.
11. Check maintenance with the volume of high speed in instruction manual or consult your dealer.
12. DO NOT REMOVE OR OBSCURE THIS SIGN.

**NOTICE**  
Replace the hydraulic oil every six months or every 1,500 hours of operation oil specification:  
Shell: TELLUS 27  
Mobil: DTE OIL LIGHT HYDRAULIC 28

**WARNING**  
Impact Hazard  
WEAR SAFETY SHOES.  
Do not approach work dropping area during operation.

**CE**

**COSEN MACHINERY INDUSTRIAL CO., LTD.**  
MODEL: C-800NC / C-1000NC  
SERIAL NO.:  
MFR: COSEN MACHINERY INDUSTRIAL CO., LTD.  
BLVD. 200-1  
TEL: 86-574-83511111  
FAX: 86-574-83511111

**WARNING**  
POWER VOLTAGE: V  
CYCLE: HZ  
TOTAL POWER: KW

**DANGER**  
Electrical Shock  
Turn Power Off before operation.  
The warning sign nearby.

**WARNING**  
Please add antifreeze coolant when the ambient temperature is below 0°C (32°F).

## HEARING PROTECTION

Noise has a major effect on the quality of your work environment. Here we refer you to testing data and information as follows:

Excessive exposure to high levels of noise may cause impairment to hearing, but the vulnerability to hearing loss varies between individuals and must be taken into account in specifying an allowable limit for noise exposure.

A level of 90 dBA is widely accepted as a criterion for 8 hour/day exposure to steady-state broadband noise. The unprotected ear should not be exposed to noise levels higher than 120 dBA.

Noise generated by the machine may come from the following:

- Saw blade during cutting or material feed mechanism
- Wire brush unit
- Chip conveyor unit
- Speed reducer
- Hydraulic motor/pump
- Belt transmissions variable speed motors
- Blade motor
- Coolant pump
- Drive wheel
- Parts not assembled tightly causing mechanical vibration

When your machine is running, noise will come out. This is a machine-electric interface problem that may make people feel uncomfortable. Our products pass noise testing less than 78 dBA. If your machine produces an undesirable noise while it is running, you should:

1. Make sure all maintenance tasks have been performed following the prescribed maintenance schedule (Refer to Section 8)
2. If maintenance does not seem to solve the problem, follow the troubleshooting procedures under Section 9.

## CE COMPLIANCE

**Cosen's** CE model is designed to satisfy regulations of the Council Directive on the approximation of the laws of the Member States relating to machinery ([2006/42/EC](#)) - Annex I Essential health and safety requirements relating to the design and construction of machinery.

## RISK ASSESSMENT

Risk assessment generally takes account of intended use and foreseeable misuse, including process control and maintenance requirements. We made every effort to avoid any personal injury or equipment damage during the machine design stage. However, the operator (or other people) still needs to take precautions when handling any part of the machine that is unfamiliar and anywhere on the machine that has potential hazards (e.g. the electrical control box).

# *GENERAL INFORMATION*

## **SPECIFICATION**

## **MACHINE PARTS IDENTIFICATION**

## **FLOOR PLAN**

This band saw machine is designed by Cosen's R&D engineers to provide you the following features and advantages:

### Safety

- This machine is designed to fully protect the operator from its moving parts during cutting operation.
- The machine and each component has passed strict testing (Council Directive on the approximation of the laws of the Member States relating to Machinery).
- The machine will shut off automatically when the saw blade is broken, protecting both the operator and the machine.

### Convenience & High-Performance

- The machine is designed in the way that the operation and adjustment can be easily performed.
- The machine will stop automatically when out of stock.
- Dual valve system is designed to achieve optimal cutting performance with the simple setting of feed rate and perspective cutting pressure for different material.

## SPECIFICATION

Model / Name of Equipment		<b>C-800NC</b> SNC-100 Programmable Automatic Mass Production Horizontal Bandsaw
	Round	800 mm (31.5 in)
	Square	800 x 800 mm (31.5 x 31.5 in)
	Rectangle (H x W)	800 x 850 mm (31.5 x 33.5 in)
Top Clamp Capacity	Bundle Cutting	W : 280 ~ 850 mm (11 ~ 34 in) H : 247 ~ 800 mm (9.7 ~ 31 in)
Saw Blade	Speed	15~80 m/min (49~262 ft/min)
	Size (L x W x T)	8300 x 67 x 1.6 mm (326.8 x 2.64 x 0.06 in)
	Pressure	45~50 kgs / cm <sup>2</sup> (tolarence:+1~+2 kgs / cm <sup>2</sup> )
	Tension	Hydraulic with automatic blade breakage detection 2500~2700 kgs / cm <sup>2</sup> (tolarence:+100~+150 kgs / cm <sup>2</sup> )
	Guide	Interchangeable tungsten carbide
	Cleaning	Steel wire brush with flexible drive shaft driven by main motor
Main Electricity Output *	Saw Blade	10 HP (7.5 kW) / 15HP (Option)
	Hydraulic	3 HP (2.25 kW)
	Coolant Pump	1/2 HP (0.375 kW)
saw bow down feed ( if available )		Infinitely Speed Programmable Proportional Valve
Servo shuttle feeding ( if available )		1 HP ( 0.75KW) Servo Driven Ball Screw Feed
Tank Capacity	Hydraulic	100 L (26.4 gal)
	Coolant	120 L (31.7 gal)
Vise Clamping	Control Method	Hydraulic with full stroke cylinder
Remnant Length		340 mm
Feeding	Control Method	-----
	Vise-Clamping Material Pull Weight	-----
	Speed	-----
	Single Stroke	-----
	Multi Stroke	-----
Workbed	Height	630 mm (24.8 in)
Weight	Net	7850 kg (17300 lb)
	Gross	8500 kg (18739 lb)
Floor Space (L x W x H)		2111 x 4226 x 2870 mm (83.1 x 166.4 x 113 in.)
Operating Environment	Temperature ( ° C )	5~40 ° C (41~104 ° F)
	Humidity (%)	30~85% (without condensation)

\*Please refer to the formula "Watt/Voltage = Amperage" with the information above.

\*Design and specification are subjected to change without notice.

\*The saw blade pressure and tension standard above are the general values. For special saw blade, please contact to your saw blade manufacturer for the applicable values.

## SPECIFICATION

Model	<b>C-1000NC</b> NC Controlled Automatic Bandsaw	
Capacity	Round	1000 mm (39.4 in)
	Square	1000 x 1000 mm (39.4 x 39.4 in)
	Rectangular (H x W)	1000 x 1000 mm (39.4 x 39.4 in)
Saw Blade	Speed	15~80 m/min (49 ~262 ft/min)
	Size (L x W x T)	9400 x 67 x 1.6 mm (370 x 2.64 x 0.06 in)
	Pressure	45~50 kgs / cm <sup>2</sup> (tolarence:+1~+2 kgs / cm <sup>2</sup> )
	Tension	Hydraulic with automatic blade breakage detection 2500~2700 kgs / cm <sup>2</sup> (tolarence:+100~+150 kgs / cm <sup>2</sup> )
	Guide	Interchangeable tungsten carbide
	Cleaning	Steel wire brush with flexible drive shaft driven by main motor
Motor Output	Saw Blade	15 HP (11.25 kW)
	Hydraulic	3 HP (2.25 kW)
	Coolant Pump	1/2 HP (0.375 kW)
	Other components	-----
Tank Capacity	Hydraulic	100 L (26.4 gal)
	Coolant	120 L (31.7 gal)
Vise Clamping	Control Method	Hydraulic with full stroke cylinder
	Min. Clamping Capacity	-----
	Clamping Pressure	-----
Remnant Length	395 mm	
Feeding	Control Method	Hydraulic Control
	Speed	-----
	Single Stroke	-----
	Multi. Stroke	-----
Workbed	Height	640 mm (25.2 in)
	Weight Capacity	-----
Weight	Net	11000 kg (23626 lb)
	Gross	12200 kg (26200 lb)
Floor Space (L x W x H)	2050 x 4678 x 3510 mm (80.7 x 184.2 x 138.2 in)	
Operating Environment	Temperature (° C)	5~40° C (41~104° F)
	Humidity (%)	30~85% (without condensation)

\*Please refer to the formula "Watt/Voltage = Amperage" with the information above.

\*Design and specification are subjected to change without notice.

\*The saw blade pressure and tension standard above are the general values. For special saw blade, please contact to your saw blade manufacturer for the applicable values.

# MACHINE PARTS IDENTIFICATION

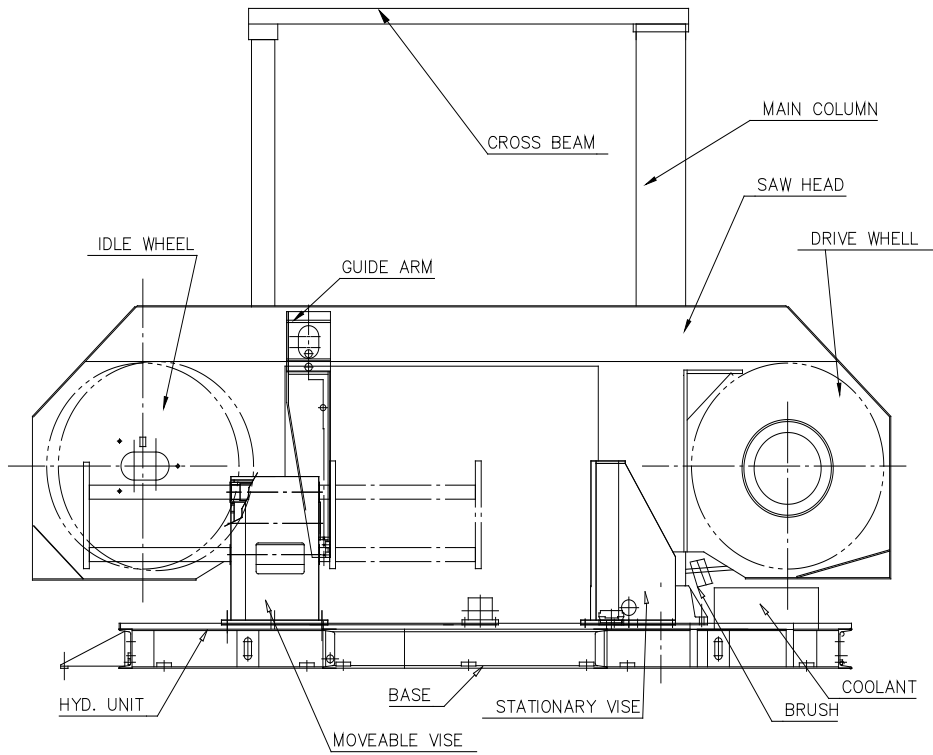

Machine back view

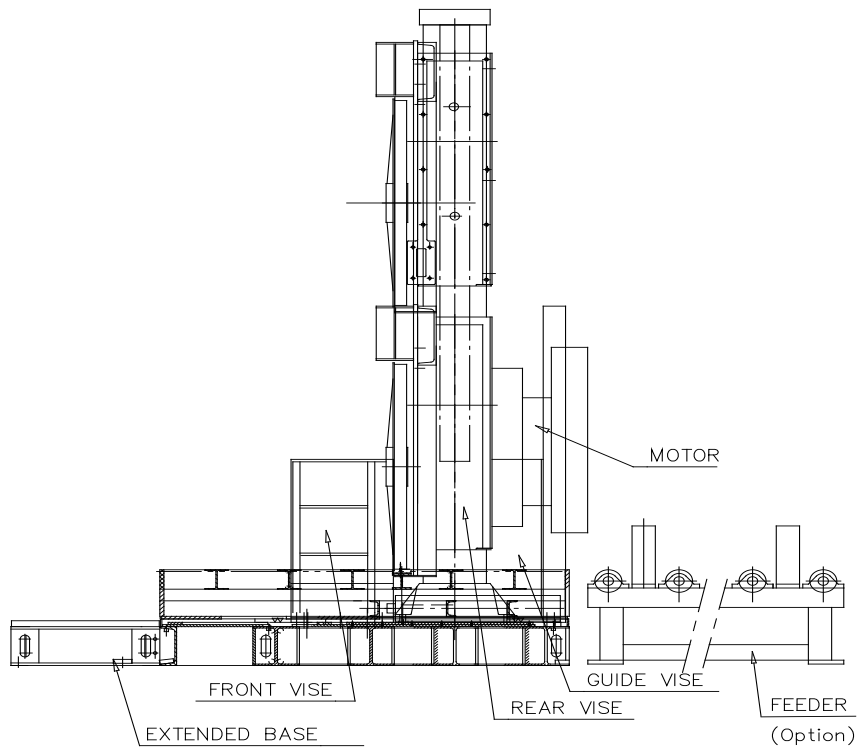

Machine side view

**FLOOR PLAN**  
**(NON-CE)**

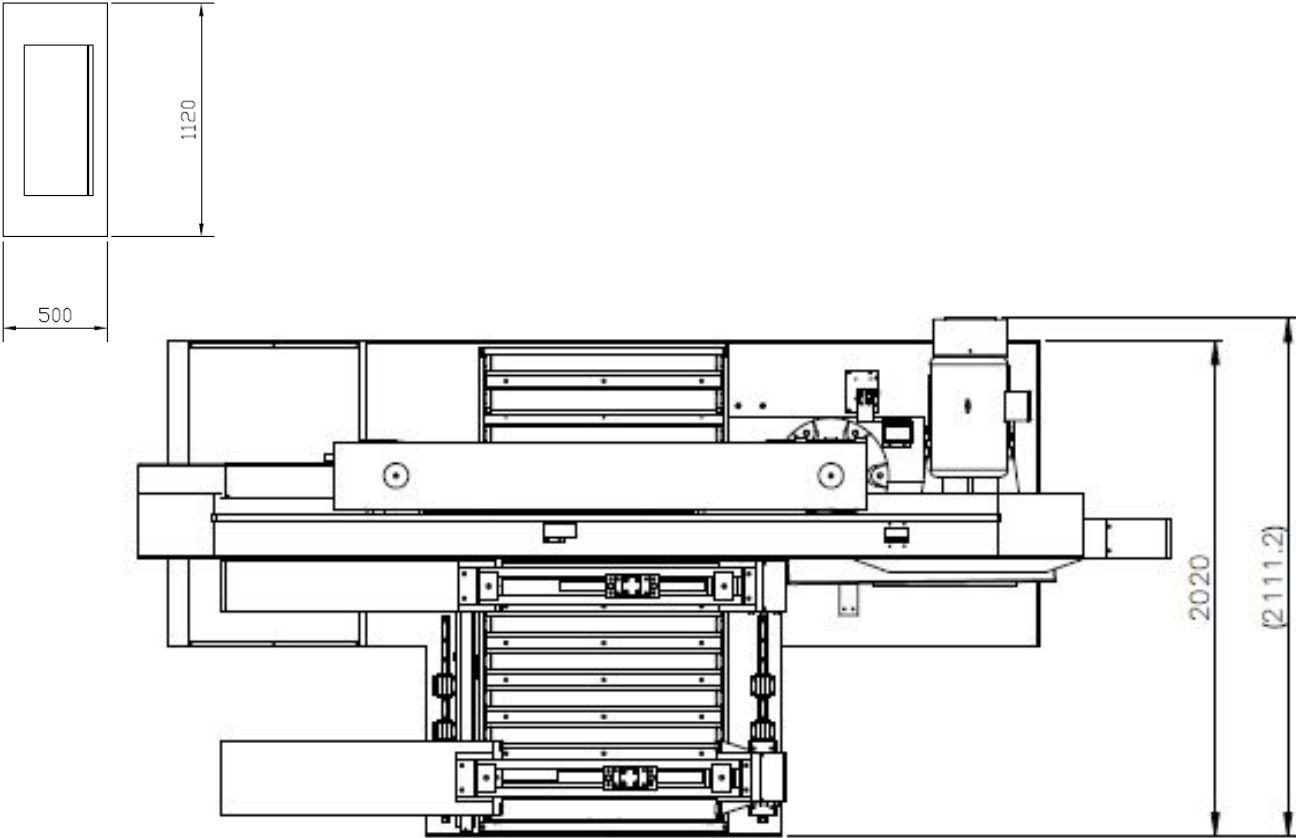

**Machine top view**

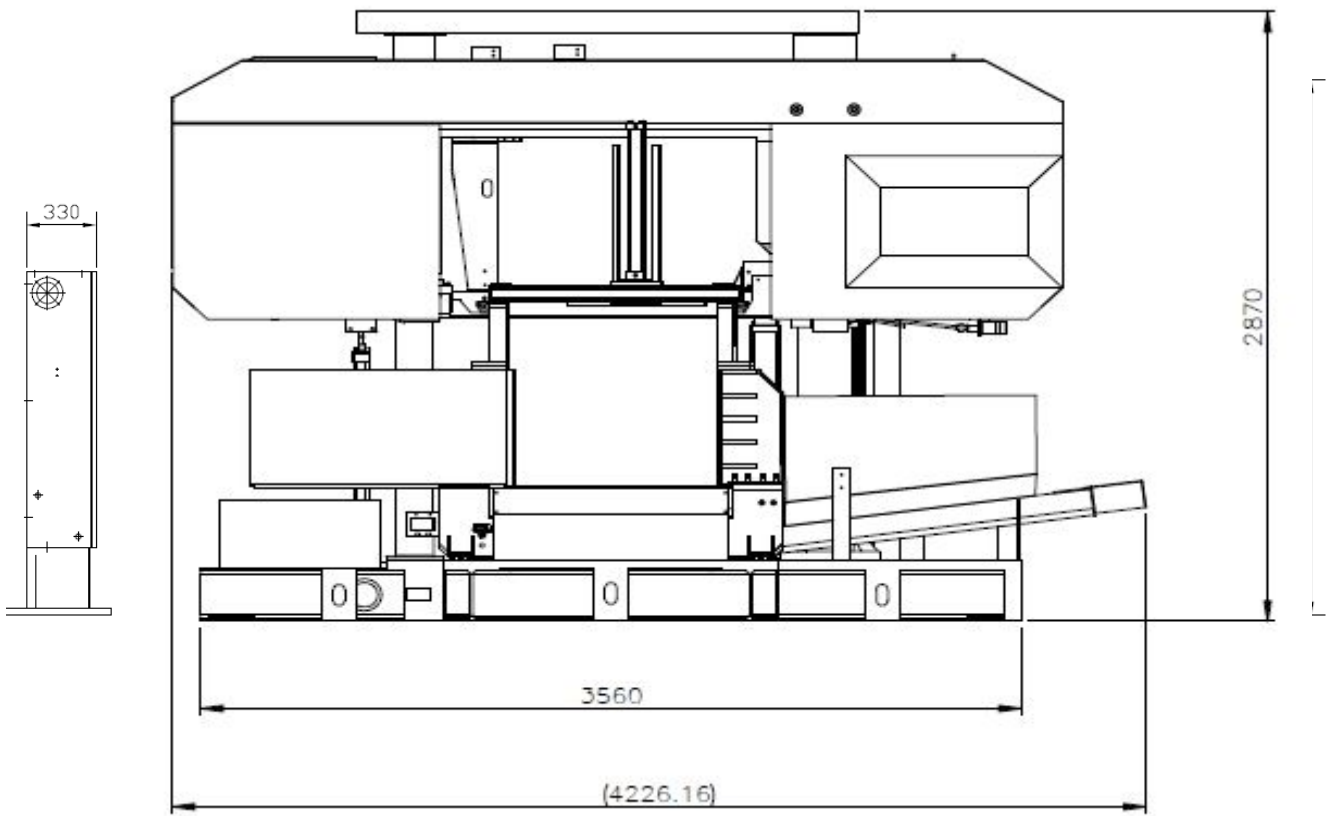

**Machine back view**

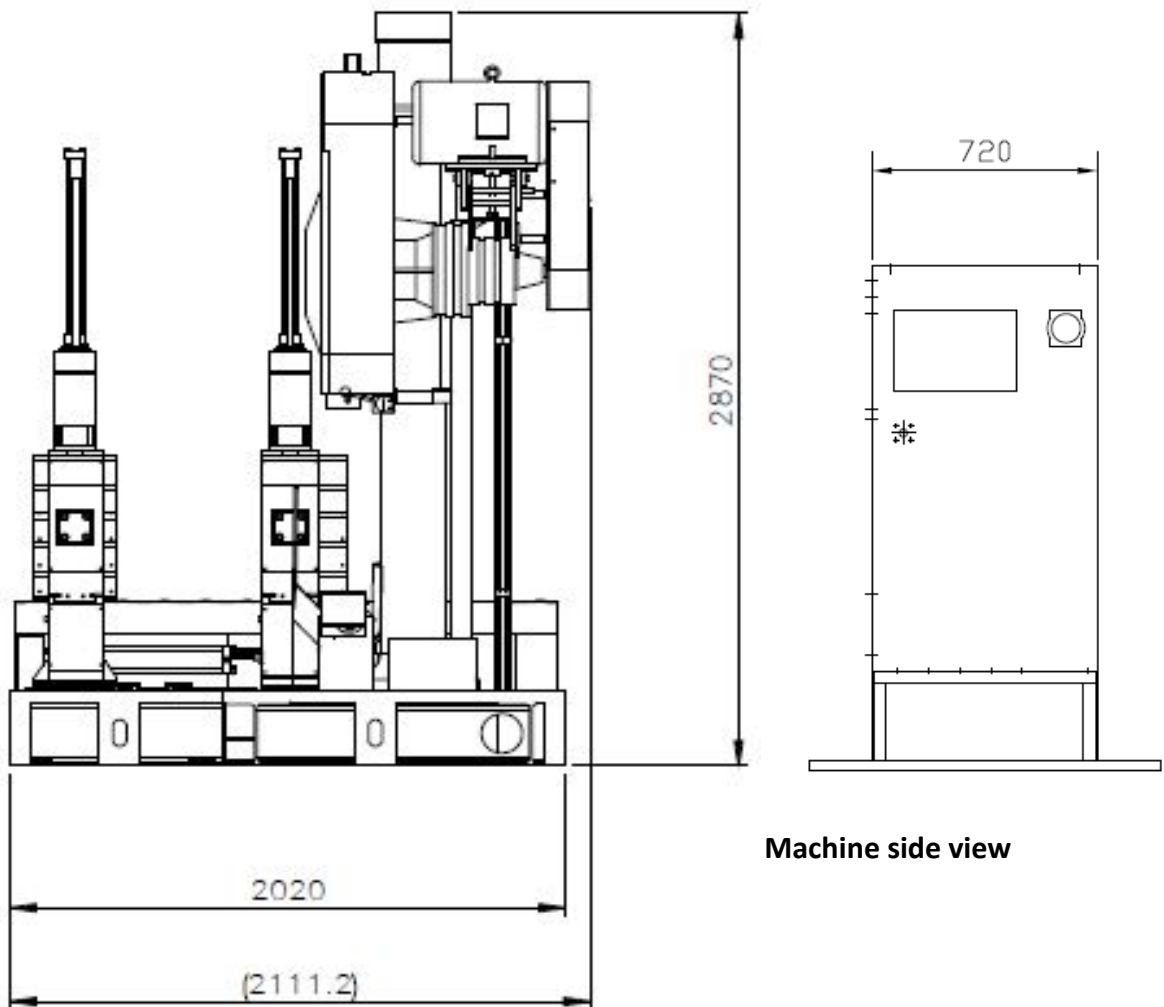

**Machine side view**



**C-1000NC**

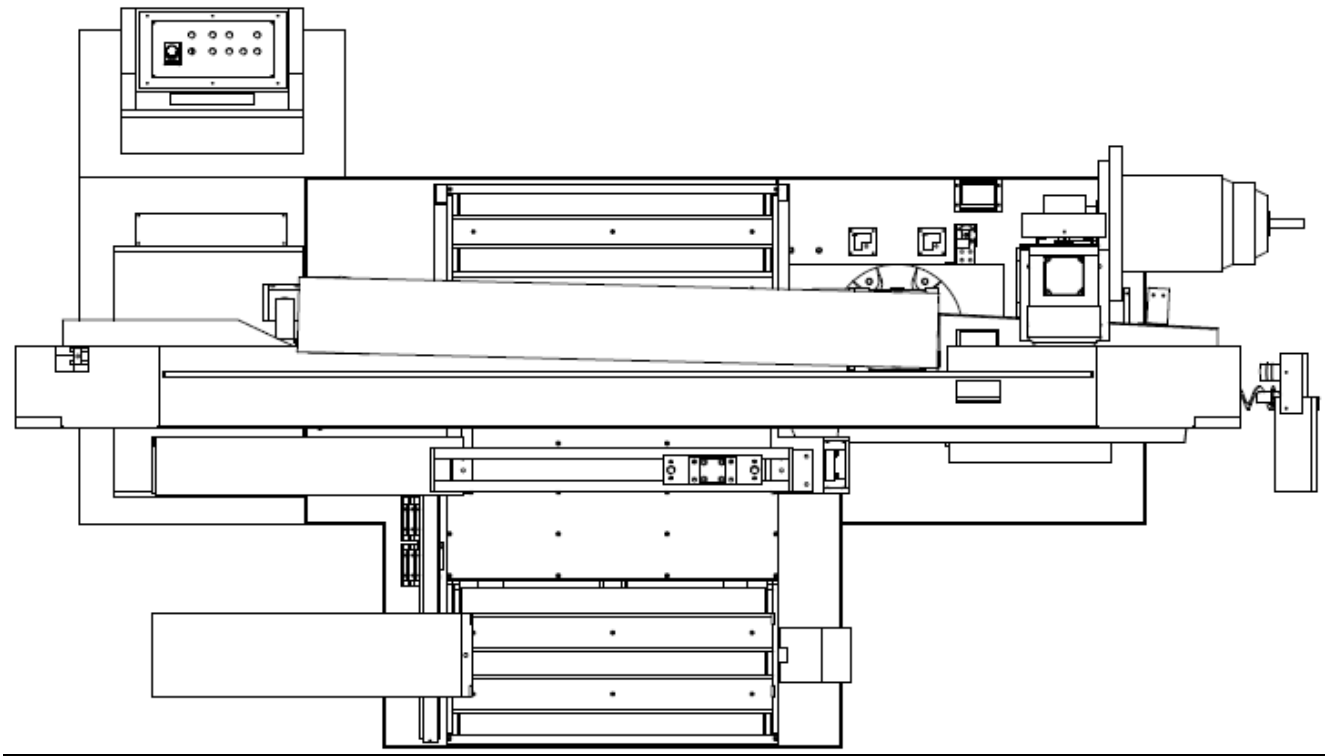

**Machine top view**

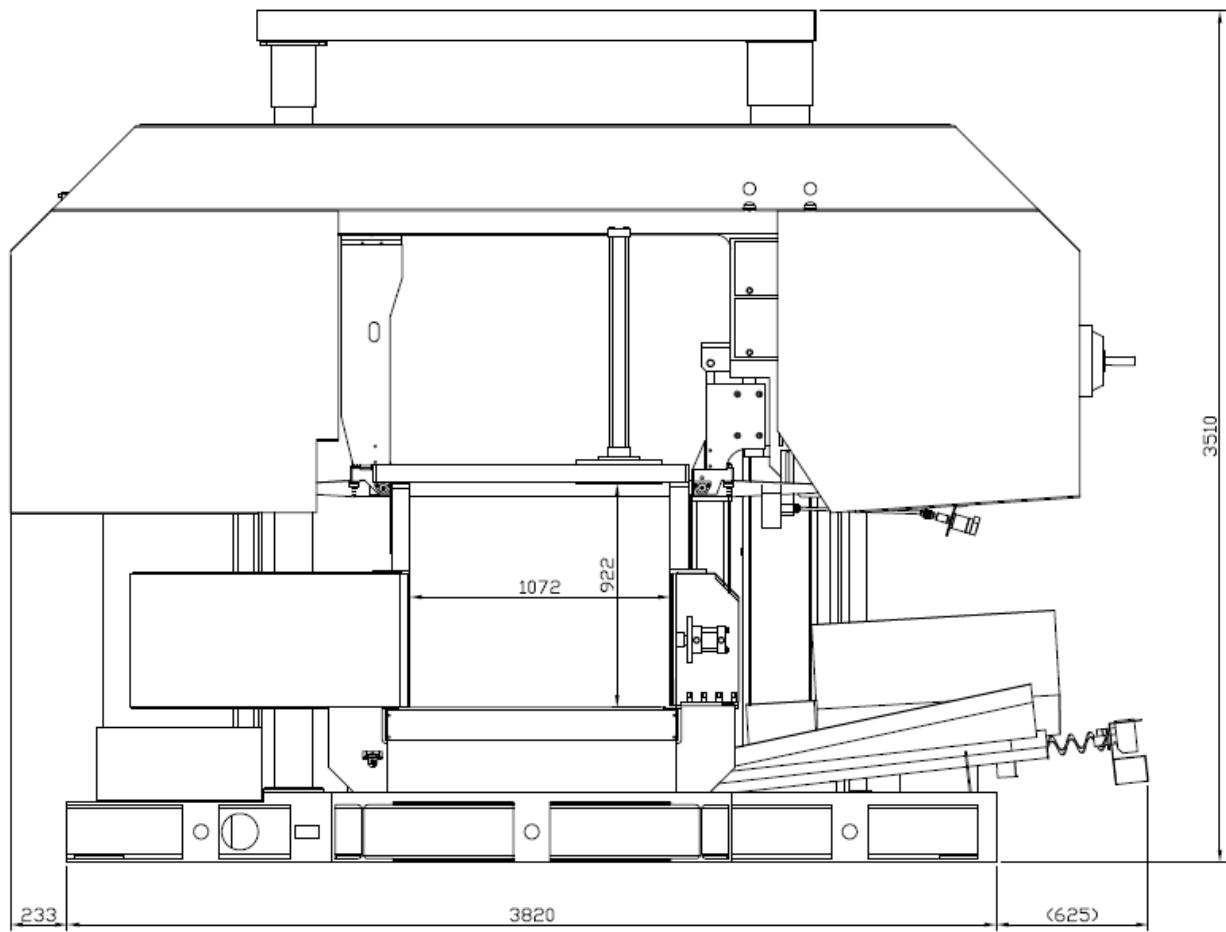

**Machine back view**

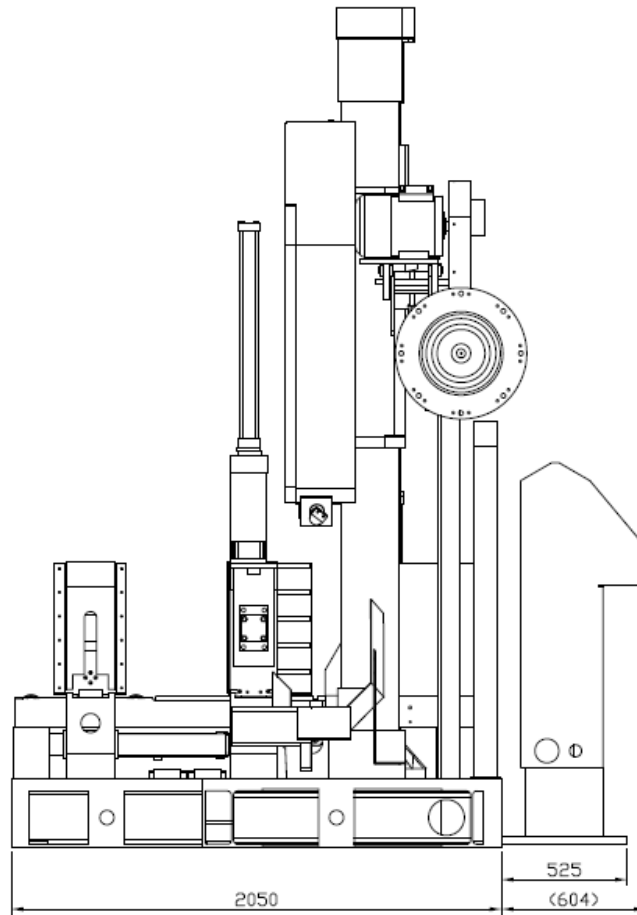

**Machine side view**

# MOVING & INSTALLATION

LOCATION & ENVIRONMENT

UNPACKING & INSPECTING

LIFTING

REMOVING SHIPPING BRACKET

CLEANING

INSTALLING

RELOCATING

## LOCATION & ENVIRONMENT

For your safety, please read all information regarding installation before proceeding. Install your machine in a place satisfying all of the following conditions:

### Space:

- Leave enough free space around the machine for loading work and unloading cut-off pieces as well as for maintenance and inspection. Refer to *Section 1 Description* for machine dimensions and floor space.

### Environment:

- Well lighted (500 lumen at minimum).
- Floor kept dry at all times in order to prevent operators from slipping.
- Away from direct exposure to the sunlight
- Room temperature between 5°C to 40°C.
- Humidity level kept at 30%~85%“(without condensation) to avoid dew on electric installation and machine.
- Away from vibration of other machines
- Away from powders or dusts emitted from other machines
- Avoid uneven ground. Choose a solid level concrete floor which can sustain weight of approximately 15 tons (including both machine and material weight).
- Limit the operation area of the machine to staff only.

## UNPACKING & INSPECTING

- Unpack your machine carefully to avoid damage to machine parts or surfaces.
- Upon arrival of your new band saw, please confirm that your machine is the correct model and it comes in the same specification you ordered by checking the model plate on the machine base.
- It is also imperative that a thorough inspection be undertaken to check for any damage that could have occurred during shipping. Pay special attention to machine surface, equipments furnished and the electrical and hydraulic systems for damaged cords, hoses and fluid leaks.
- In the event of damage caused during shipping, please contact your dealer and consult about filing a damage claim with the carrier.
- Your machine comes in with a set of tools for you to maintain the machine. The accessories furnished are as follows:
  1. Tool box 1 pc
  2. Grease gun 1 pc
  3. Screwdriver (+, -) 2 pcs
  4. Open-ended spanner 3 pcs
  5. Hexagon wrench 1 set
  6. Chip spade (only for manual models) 1 pc
  7. Operation manual 1 pc



Should you find any missing accessories, please contact your local agent immediately.

## LIFTING

When moving the machine, we strongly suggest you choose any one of the methods described below to move your machine.



1. **Use a crane (Only applies to the machine with the design of the hanging point.)**

Move the machine to its location by using a crane and a wire rope sling that can fully withstand the weight of the machine (refer to machine specification under Section 2 *General Information*).



Machine hanging with a crane should be done strictly according to the hanging points designated by the original manufacturer. If there is any doubt on missing hanging points on your machine, please consult with the original manufacturer or its qualified agent before hanging the machine.

- Machine lifting is likely to damage the machine if not performed properly.



You must have a qualified crane operator to perform the job.



- You must use tools and equipment with the proper tensile strength and use proper method when moving your machine.

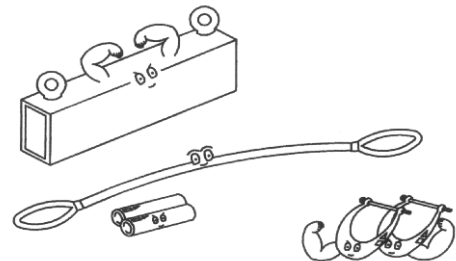

- Apply the wire rope sling to the lifting hooks on the four ends of the machine. Refer to *Illustration: Lifting Points for exact locations*.
- Slowly lift the machine. Be sure to protect the machine from impact or shock during this procedure. Also watch out your own fingers and feet to avoid injuries.
- Keep the machine well balanced during lifting process and make sure the wire rope does not interfere with the saw frame.

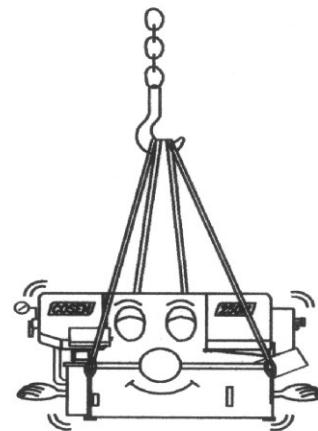

- When you work together with more than two people, it is best to keep constant verbal communication with each other.

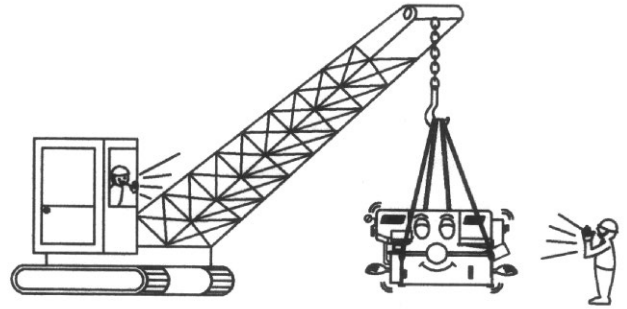

2. **Use a forklift (Only applies to the machine with the design of the lifting point.)**

Make sure that the lifting rod can fully withstand the weight of the machine. (Refer to *Section 2 – General Information for Specifications.*)



Machine lifting with a forklift should be done strictly according to the lifting points designated by the original manufacturer. If there is any doubt on missing lifting points on your machine, please consult with the original manufacturer or its qualified agent before lifting the machine.

- Machine lifting is likely to damage the machine if not performed properly.



You must have a qualified forklift operator to perform the job.



- You must apply proper forklift technique to avoid damage to the machine.



Make sure the forks are able to reach in at least 2/3 of the machine depth.

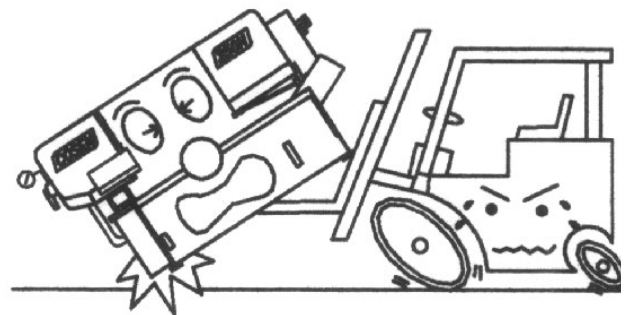

- You must keep the machine balanced at all times.



Make sure the forks are centered before use.

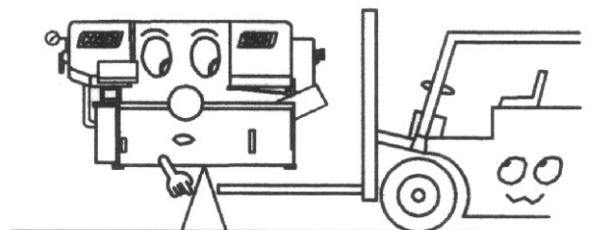

(Illustration only.)

### 3. Use rolling cylinders

You can use rolling cylinders to move your machine in a small machine shop environment.

- You must use rolling cylinders made in material of proper compressive strength.

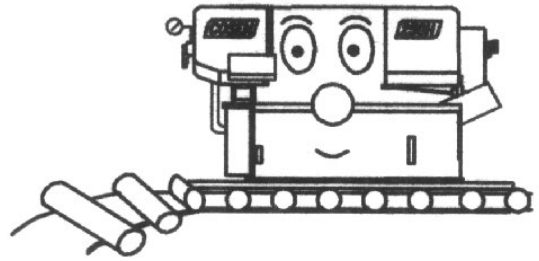

### 4. Other ways to move

If the machine does not have



or



stickers, please contact your local agent immediately.

**Illustration: Lifting Points**

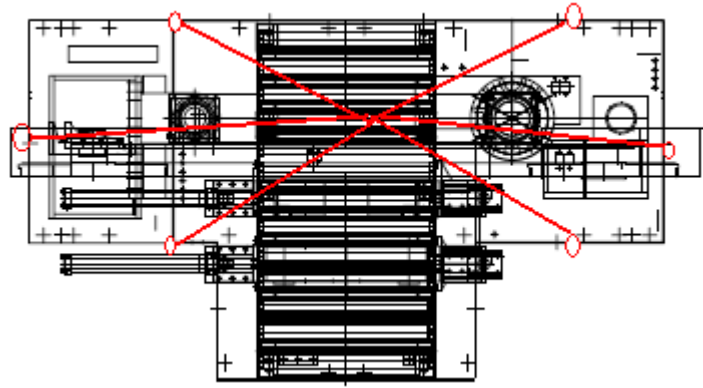

**Machine top view**

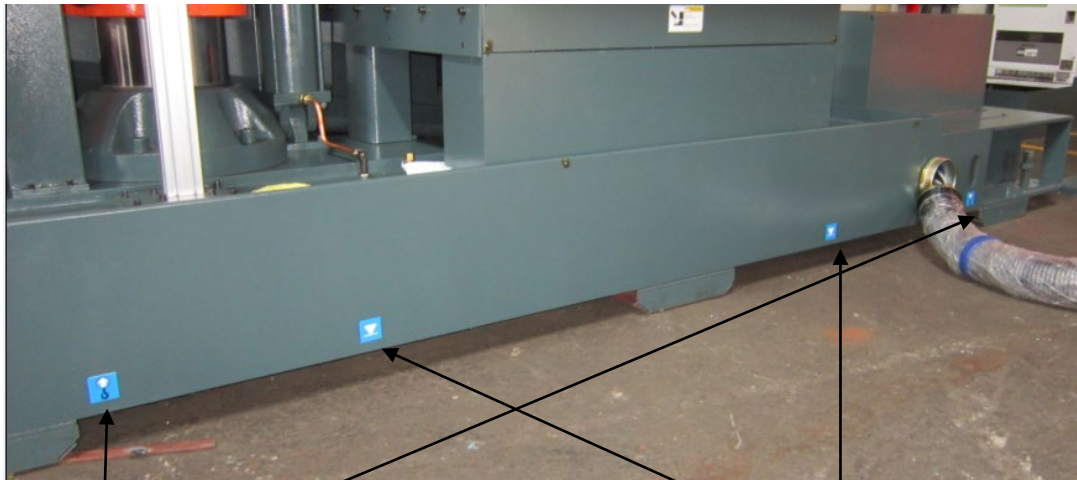

Crane lifting points

Forklift lifting points



Please remove the covers first before lifting.

Minimum weight capacity for each wire rope:

**9 tons for C-800NC**

**13 tons for C-1000NC**

Total number of wire ropes required: **4**



## REMOVING SHIPPING BRACKET

- After the machine has been properly positioned, remove the shipping bracket that is used to lock the saw frame and the saw bed.
- Retain this bracket so that it can be used again in the event that your machine must be relocated.

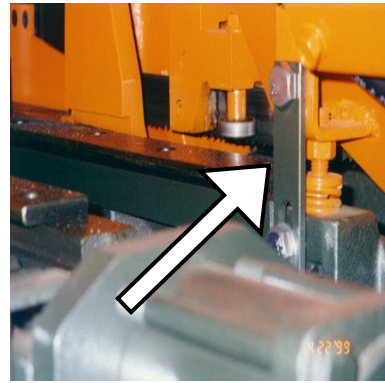

## CLEANING

After the machine has been placed at the designated position, remove the rust-preventive grease with wiping cloth dampened with cleaning oil or kerosene. Apply machine oil to machine surfaces that are prone to rust.



Do not remove the rust-preventive grease with a metal scraper and do not wipe the painted surfaces with solvent as doing so would damage surface paint.

## INSTALLING

Cosen's bandsaw machine is relatively easy to install. Follow these six easy steps to install your machine.

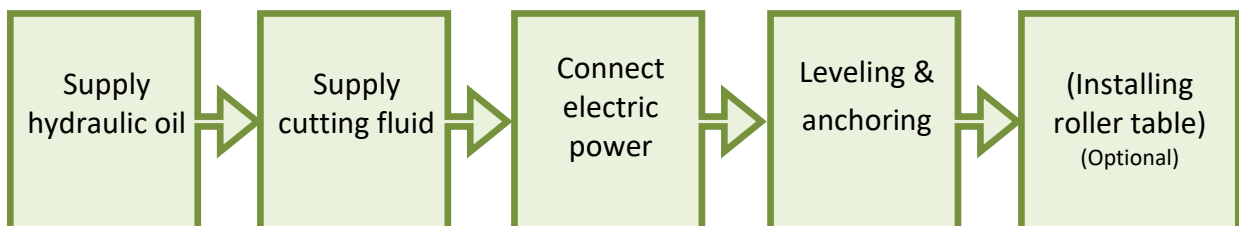



### Supplying hydraulic oil

Open the filler cap and fill the hydraulic oil tank to above 2/3 or full level.

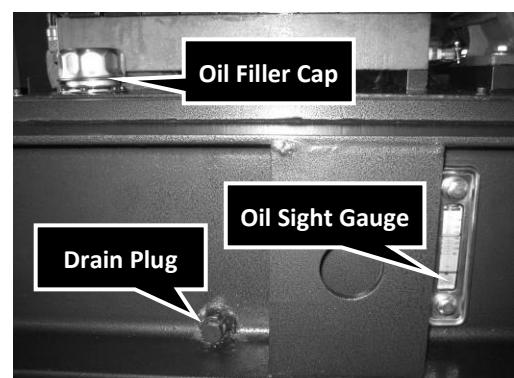
Check the sight gauge to make sure the oil level in the tank.







-  Refer to specification chart under Section 1 for tank capacity.
-  Oil tank should be full already if it is a new machine that operates for the first time.

### **Supplying coolant**

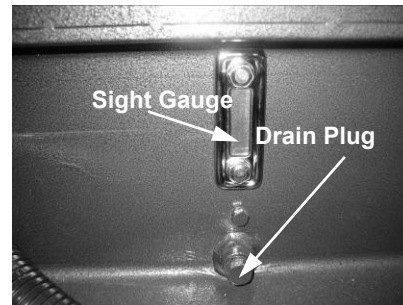







Fill the coolant tank to the middle level of the sight gauge by pouring the coolant from above the chip conveyor.

Use the sight gauge to check the coolant level remaining in the tank.



-  Always check the coolant supply before starting the machine. If the coolant pump is started without enough coolant supply in the tank, the pump and its drive motor may be damaged.
-  Refer to specification chart under Section 1 *Description* for tank capacity.
-  Consult your coolant supplier for bandsaw use regarding coolant type and mix ratio.

### **Connecting electric power**

-  Have a qualified electrician make the electrical connections.
-  If the power supply voltage is different from the transformer and motor connection voltage shown on the label attached to the electrical compartment of the machine, contact COSEN or your agent immediately. 
-  Connect to power supply independently and directly. Avoid using the same power supply with electric spark machines such as electric welder. Unstable electric tension may affect your machine's electric installation from working properly.
-  Ground the machine with an independent grounding conductor.
-  Supply voltage: 90% - 110 % of nominal supply voltage.
-  Source frequency: 99% - 101 % of nominal frequency.
-  Refer to the specification chart under Section 1 for total electric power consumption of the motors and make sure your shop circuit breaker is capable of this consumption amount. Also use a power supply cable of proper size to suit the power supply voltage.

1. Turn off the shop circuit breaker.
2. Make sure the machine circuit breaker switch on the electrical compartment door is turned to OFF.
3. Remove the screw securing the electrical compartment and then open the door.
4. Pull the power supply cable and grounding conductor through the power supply inlet into the electrical compartment. (Shown right)
5. Connect the power supply cable to the circuit breaker (N.F.B.) to the R, S and T terminals, and connect the ground cable to the E terminal.
6. Close the compartment door and fasten the screw back.
7. Turn on the shop circuit breaker and then turn the machine circuit breaker switch to ON. The *Power Indicator* on the control panel will come on.
8. Pull to unlock the *Emergency Stop* button and press the *hydraulic ON* button to start the hydraulic motor.
9. Make sure the sawing area is clear of any objects. Start the blade and check the blade rotation. If the electrical connections are made correctly, the blade should run in a counterclockwise direction. If not, shut the hydraulics off, turn off the machine as well as the shop circuit breaker. Then swap the power the power cable conductors connected to R and T terminals.
10. Repeat step 6 to 9 to ensure the electrical connections are in the right order.

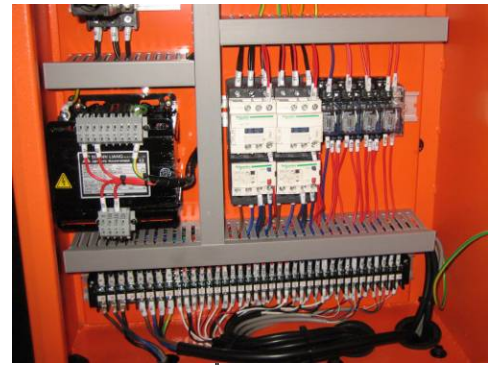

Power Supply Inlet

### Leveling

Place spirit level on the vise slide plates and the work feed table.

Level the machine in both directions i.e. along and across the machine. Adjust the level of the machine by turning the leveling bolts.

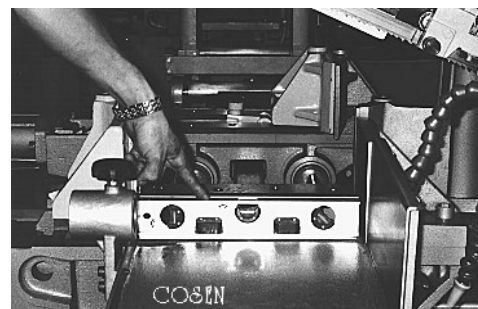

Make sure all leveling bolts evenly support the machine weight.



In some cases, leveling the machine with a slight slope toward the front of the machine is recommended as it would prevent coolant from running down cutting material especially tubes or bundles. To do so, make the rear end of the machine approximately 10 mm higher than the level of the front end.

## **Anchoring the machine**

Normally there is no need to anchor the machine. If the machine is likely to vibrate, fix the machine to the floor with anchor bolts.

Shock absorption steel plates are provided and can be placed under each leveling bolt to prevent their sinking into the concrete floor.

## **Installing roller table (optional)**

The roller table is used to support long material at the rear and/or the front of the machine.

If you have ordered the optional roller table for cutting long material, position it before or behind the machine.

Level the roller table and the stand with the machine by adjusting the leveling bolts.

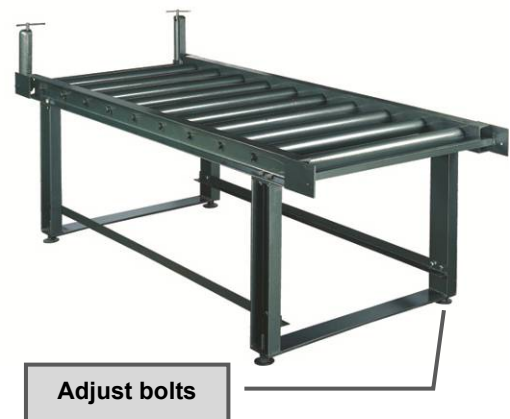

## **Installing Fire Control Device**

Install a fire extinguisher or any other fire control device in the shop in case a fire breaks out.

## **RELOCATING**

We recommend you follow these procedures when relocating or shipping your machine to other place:

1. Descend the saw frame to its lowest position then turn off the power.
2. Fix the saw frame using the shipping bracket that originally came with the machine.
3. If you are shipping the machine, pack the machine carefully with industrial plastic wraps to protect it from dust.
4. Use a crane or forklift to raise it. If a crane is used to lift the machine, ensure that the lifting cable is properly attached to the machine.
5. Do not forget to include the equipments originally furnished including the shock absorption steel plates and the instruction manual.

# *OPERATING INSTRUCTION*

**SAFETY PRECAUTIONS  
BEFORE OPERATING  
CONTROL PANEL  
STANDARD ACCESSORIES  
ADJUSTING SAW BOW INCLINING ANGLE  
UNROLLING & INSTALLING THE BLADE  
ADJUSTING WIRE BRUSH  
PLACING WORKPIECE ONTO WORKBED  
POSITIONING WORKPIECE FOR CUTTING  
ADJUSTING BLADE SPEED  
ADJUSTING COOLANT FLOW  
BREAKING-IN THE BLADE  
TEST-RUNNING THE MACHINE  
CUTTING OPERATION  
TERMINATING A CUTTING OPERATION**

## SAFETY PRECAUTIONS

For your safety, please read and understand the instruction manual before you operate the machine. The operator should always follow these safety guidelines:



- The machine should only be used for its designated purpose.
- Do not wear gloves, neckties, jewelry or loose clothing/hair while operating the machine.



- For eye protection, always wear protective safety glasses.
- Check the blade tension and adjust blade guides before starting the machine.
- Use auxiliary clamping or supporting devices to fix material in place before cutting long workpieces. Always make sure the material is clamped firmly in place before starting to cut.
- Do not remove jammed or cut-off pieces until the blade has come to a full stop.
- Keep fingers away from the path of the blade.



- Protection devices should be in place at all times. For your own safety, never remove these devices.
- Disconnect machine from the power source before making repairs or adjustments.

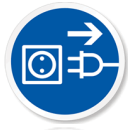

- Wear protection gloves only when changing the blade.



- Do not operate the machine while under the influence of drugs, alcohol or medication.



- Do not take your eyes off the machine while in operation.
- Do place warning signs to mark out machine work zone and restrict entry to be staff-only.

## BEFORE OPERATING

Choosing an appropriate saw blade and using the right cutting method is essential to your cutting efficiency and safety. Select a suitable saw blade and cutting method based on your work material and job requirements e.g. cutting accuracy, cutting speed, economic concern, and safety control.

### Wet cutting

If you choose dry cutting or low-speed cutting, the chips may accumulate in machine parts and may cause operation failure or insulation malfunction. We suggest you choose wet cutting to avoid machine damage.

### Cutting unknown materials

Before cutting an unknown material, consult the material supplier, burn a small amount of chips from the material in a safe place, or follow any other procedure to check if the material is flammable.



Never take your eyes off the machine while in operation.

### Cutting fluid

For cooling and lubrication purpose, we recommend you use water-soluble cutting fluids. The following table lists out its pros and cons for your reference.

Pro	Con
<ul style="list-style-type: none"><li>• Have a high cooling effect</li><li>• Not flammable</li><li>• Economical</li><li>• Does not require cleaning of the cut products</li></ul>	<ul style="list-style-type: none"><li>• Remove machine paint</li><li>• Lose its rust protection effect if deteriorated</li><li>• Tend to create foam</li><li>• Subject to decay</li><li>• Decline in performance, depending on the quality of the water used for dilution</li></ul>



Never use water as your coolant.



Always add coolant into water for better mix result.



Consult your coolant supplier for bandsaw use regarding coolant type and mix ratio.



Before starting a cutting job, make sure there is sufficient amount of coolant in the tank.

Check the fluid level through the sight gauge. Please refer to machine specifications in this manual (Section 2) for tank capacity.

## CONTROL PANEL

The control panel is located on the top of the electrical box. It includes the following function: power system, hydraulic system, cooling system, the human-machine-interface (HMI) and the projecting light system. The operator must fully understand the function of each switch and button before operating the machine.

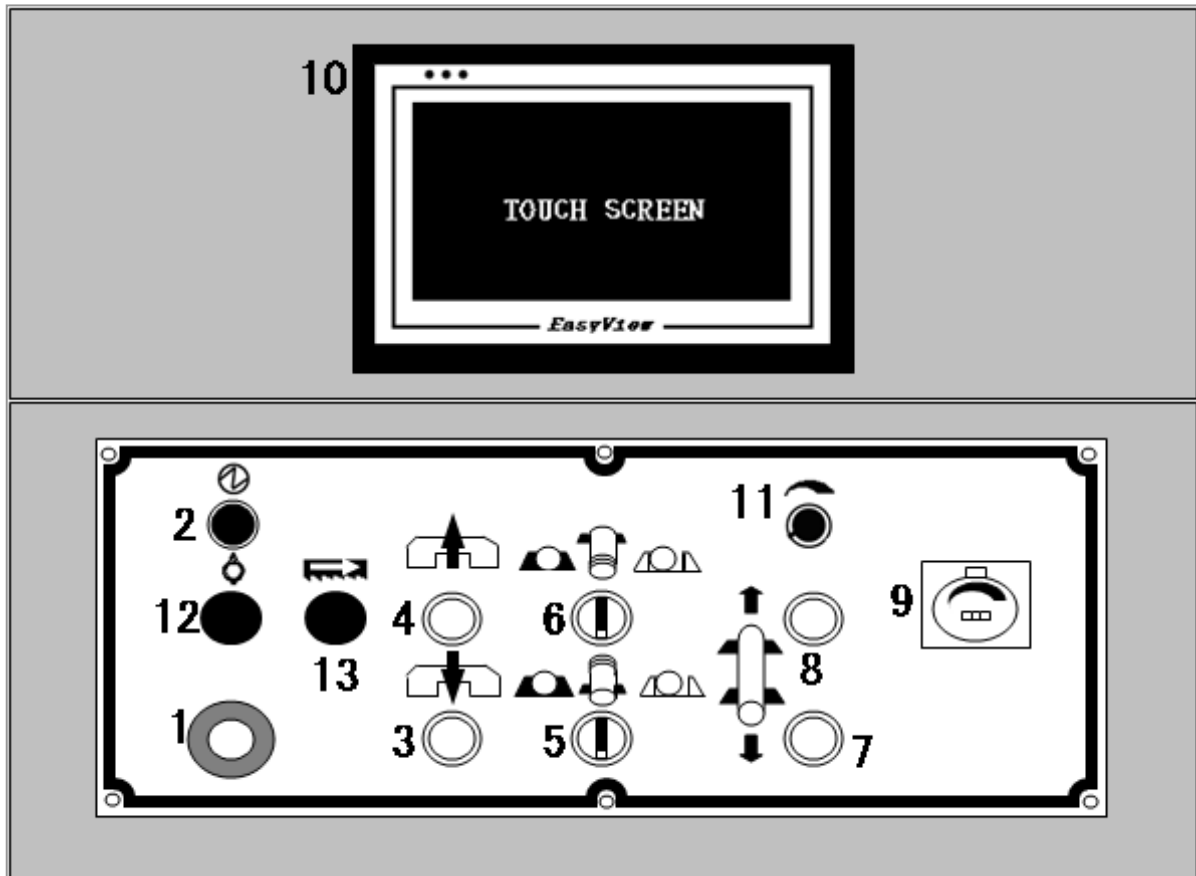

Non-CE Model Control Panel for C-800NC



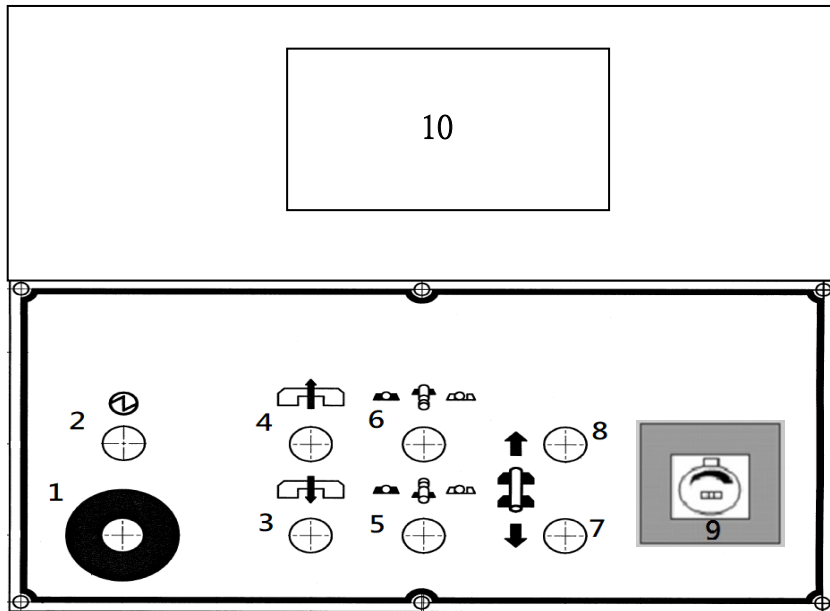

Non-CE Model Control Panel for C-1000NC

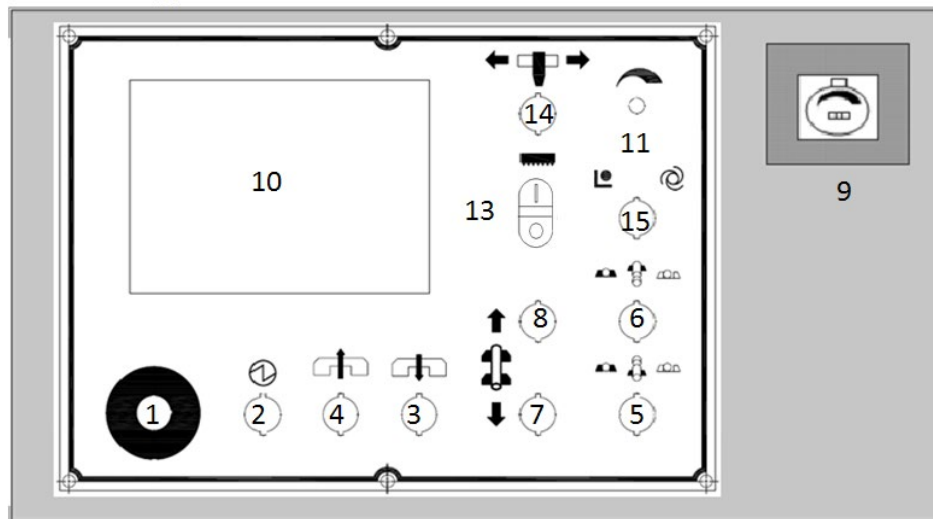

CE Model Control Panel

No.	Name	No.	Name
1	Emergency stop button	9	Blade descend speed control knob
2	Power indicator lamp	10	HMI touch screen
3	Saw bow down button	11	Blade speed control knob
4	Saw bow up button	12	Hydraulic start button (moved into HMI)
5	Front vise open/clamp switch	13	Saw blade start/stop buttons with built-in lamp
6	Rear vise open/clamp switch	14	Guide arm left/right switch
7	Feeding bed forward button	15	Setting/cutting mode key switch
8	Feed bed backward button		

## Control Buttons

### 1. Emergency stop button

Press this button to stop the machine in an emergency. When the button is pressed, it brings the machine to a full stop. The button locks when pressed. In order to unlock it, please turn the button clockwise.

### 2. Power indicator lamp

When the lamp is on, it indicates the power to the machine is turned on.

### 3. Saw bow down button

When this button is pressed, the saw bow descends quickly (the quick approach limit switch must be engaged). When the quick approach limit switch is not engaged and this button is pressed, the saw bow descends according to the blade descend speed control knob setting.



Before lowering the saw bow, the guide arm must be positioned outside the vise in order to avoid hitting the vise and causing damages.

### 4. Saw bow up button

When this button is pressed, the saw bow rises until the operator lets go of the button or until the saw bow touches the upper limit switch.



While pressing the saw bow up button can stop the running blade, please still use the emergency stop button in an emergency.

### 5. Front vise open/clamp switch

Turn this button to the right to [open], and the front vise will open until the button is released. Turn this button to the left for [close] position, and the vise will clamp until the button is released.



When the saw bow is below the middle limit switch position, the front vise can only be opened in small increments in order to avoid hitting the guide arm.



This is double retraction vise, thus the fixed vises will start moving one to two seconds ahead of the movable vises to avoid the material from falling off or hitting during cutting.



CE model This switch only works when the machine is switched to setting mode “  ”.

### 6. Front vise open/clamp switch

Turn this button to the right to [open], and the front vise will open until the button is released. Turn this button to the left for [close] position, and the vise will clamp until the button is released.



This is double retraction vise, thus the fixed vises will start moving one to two seconds ahead of the movable vises to avoid the material from falling off or hitting during cutting.



CE model This switch only works when the machine is switched to setting mode “”.

## 7. Feeding bed forward button

When this button is pressed, the feeding workbed will move forward. Press and hold the button to feed forward. As soon as the button is released, the feeding workbed will stop moving forward.



This button is only in function when the quick approach limit switch is engaged AND when either of the front and rear vises are unclamped.



After the blade motor starts running, this button is disabled due to safety concerns.



CE model This switch only works when the machine is switched to setting mode “”.

## 8. Feeding bed backward button

When this button is pressed, the feeding workbed will move backward. Press and hold the button to feed backward. As soon as the button is released, the feeding workbed will stop moving backward.



This button is only in function when the quick approach limit switch is engaged AND when either of the front and rear vises are unclamped.



After the blade motor starts running, this button is disabled due to safety concerns.



CE model This switch only works when the machine is switched to setting mode “”.

## 9. Blade descend speed control knob

- Also commonly known as the flow control valve, this blade descend speed control knob can be set by the operator according to the material to be cut.
- Turn the knob clockwise to increase blade descend speed; turn the knob counterclockwise to decrease the blade descend speed.
- There is a little window in front of the valve indicating the set value. Also the HMI touch screen displays the current value for you to change anytime during operation.

## 10. HMI touch screen

Please refer to later section for detailed introduction.

### 11. Blade speed control knob

Blade speed is controlled by the inverter located under the workbed. Turning the knob clockwise increases the blade speed.

### 12. Hydraulic start button (moved into HMI)

### 13. Saw blade start/stop buttons with built-in lamp

When the green button is pressed, the built-in lamp comes on and saw blade starts to cut. Press the red button to stop cutting.



The blade will start only when under cutting mode “”.

### 14. Guide arm left/right switch

Turn this switch to the right to move the guide arm to the right. Turn this switch to the left to move the guide arm to the left.



The saw bow must be above the middle limit switch AND tungsten inserts must be unclamp to move the guide arm.



Be sure that the guide arm will not bump into the front vise, set the guide arm width according to the scale on top of the sliding board.

### 15. Setting/cutting mode key switch

This selector switch provides two modes to choose from: setting and cutting. To switch between these modes, a key is required. Please keep the key at a safe place and do not lose it.



#### Setting mode

The setting mode provides a safe environment while adjustment prior to cutting is conducted or when machine maintenance is required. Cutting is not allowed in the setting mode.



#### Cutting mode

Cutting is allowed only in cutting mode.

## Human-machine-interface (HMI) touch screen

This HMI touch screen displays operation messages so that the operator is able to understand the system condition. It also provides different operating modes and selections for the operator to work with. During a cutting job, the operator can still enter the system and make changes to the cutting operation as needed.



Do not wipe or clean the screen with volatile solvents.



Do not overexert pressure on the screen. The touch screen is very sensitive; all buttons on the

screen just need a slight touch to operate.



All range parameters in HMI are configured under the “manual” mode.



Please pay attention to the following environment conditions necessary for HMI touch screen to properly operate:

Item	Range
Ambient temperature	5°C ~ 50°C
Temperature for safe operation	-10°C ~ 60°C
Ambient humidity	30%~85% RH (No condensation)
Connection	RS422 MMI port
Environment	No condensation and rust



### Startup Screen

After the power is turned on, Cosen’s logo will appear as the startup screen, followed by the main operation menu.

## Main control menu

The main control menu includes some operating button that were used on the control panel of the earlier machines. Some convenient functions are added to the page for the operator to better understand the features of the machine. Setting the parameters shown on the screen requires a gentle touch of the finger. You can also look up the parameters or make changes while in the middle of a cut.

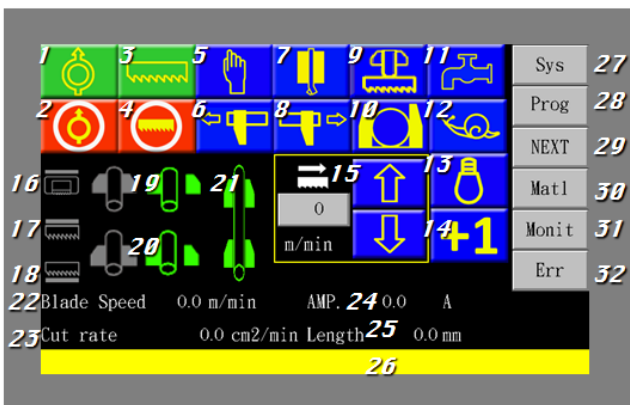



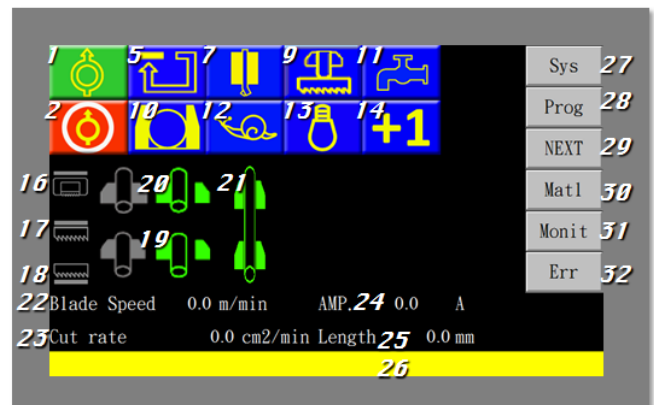













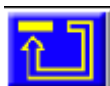





Non-CE model

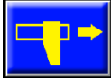









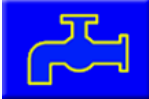





CE model

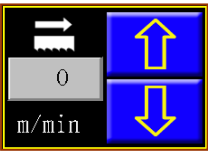







Refer to the table below for descriptions of each function.



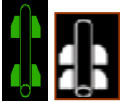

No	Item	Function	Description
1		Hydraulic start	<p>When the power is turned on, press this button to start the hydraulic motor.</p> <p>A solid yellow icon indicates the hydraulic system has been turned on.</p>
2		Hydraulic stop	<p>Press this button to turn off the hydraulic motor immediately.</p> <p> When the blade is running, the hydraulic stop button is temporarily disabled. You need to press the <i>saw blade stop</i> or the <i>saw bow up</i> button to stop the blade first.</p>
3		Saw blade start	<p>When the work piece is clamped properly, press this button to start cutting.</p> <p>A solid yellow blade icon indicates the blade has been started.</p>
4		Saw blade stop	Press this button to stop the saw blade.
5	<div style="display: flex; flex-direction: column; align-items: center;"> <div style="display: flex; gap: 10px;">   </div> <p>(non-CE model)</p> <div style="display: flex; gap: 10px;">   </div> <p>(CE model)</p> </div>	<p>AUTO/Manual mode</p> <p>AUTO/ Single cutting mode</p>	<p>Use this button to switch between AUTO and manual/single cutting mode.</p> <ul style="list-style-type: none"> <li>● <b>AUTO cutting:</b> used to automatically perform continuous cutting jobs. When switched to this mode, the machine will automatically operate according to the preset parameters.</li> <li>● <b>Manual/Single cutting:</b> used to perform one single cutting job.</li> </ul> <p> <i>Trim Cut</i> - When the machine is switched from the <b>manual/single cutting mode to the AUTO mode</b>, the first cut (trim cut) will not be counted into finished cuts and the machine will continue to operate according to the preset parameter. This function allows the machine to finish the trim cut and directly proceed into automatic cutting till the last cutting job.</p> <p> If you switch to manual/single cutting mode while cutting is already in action under AUTO mode, the machine will stop after the individual cut is finished. Switching to manual/single cutting mode at any time other than cutting, the machine will proceed with the next cut until it is finished.</p>

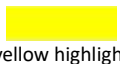
No	Item	Function	Description
6		Guide arm to the left	<p>Press this icon to move the guide arm to the left.</p> <p> The saw bow must be above the middle limit switch AND tungsten inserts must be unclamp to move the guide arm.</p> <p> Be sure that the guide arm will not bump into the front vise, set the guide arm width according to the scale on top of the sliding board.</p>
7		Tungsten inserts clamp/unclamp switch	<p>When under manual/single cutting mode, press this button to clamp Tungsten carbide inserts.</p> <p>A solid yellow icon indicates the inserts has been clamped.</p> <p>Press again to unclamp.</p> <p>The carbide inserts will automatically clamp the blade when the <i>saw blade start</i> button is pressed. This safety design is incorporated in the program to protect both the user and the blade during cutting.</p>
8		Guide arm to the right	<p>Press this button to move the guide arm to the right.</p> <p> The saw bow must be above the middle limit switch AND tungsten inserts must be unclamp to move the guide arm.</p> <p> Be sure that the guide arm will not bump into the front vise, set the guide arm width according to the scale on top of the sliding board.</p>
9		Material retract 2mm ON/OFF	<p>When this function is turned on, the machine will retract the material for 2mm after completing each cut before the blade rises from its lowest position.</p> <p>A solid yellow icon indicates the Material retract 2mm mode has been turned on.</p> <p>Press again to turn off this function.</p> <p> <b>The <i>material retract 2mm</i> function helps prevent saw blade wear by retracting the material before the saw blade rises.</b></p>
10		Single/Bundle cutting mode	<p>This button is used to switch between single or bundle cutting mode.</p> <ul style="list-style-type: none"> <li>● Switch to single cutting model () to cut a single work piece.</li> <li>● Switch to bundle cutting mode () to cut a stack of work pieces.</li> </ul> <p> <b>When under bundle cutting mode, the feeding vise must be touching the front limit switch for the blade to be able to start.</b></p>

No	Item	Function	Description
11	 	Coolant ON/OFF	<p>Press this button to turn on the coolant pump.</p> <p>A solid yellow faucet icon indicates the coolant pump has been turned on.</p> <p>Press again to turn off the coolant pump.</p>
12	 	Fast/slow material feeding mode	<p>Used only when under Manual/Single cutting mode.</p> <p>When the slow material feeding mode is turned on, the material feeding speed will dramatically reduce to help you position the work piece precisely.</p>
13	 	Projection lamp ON/OFF	<p>Press this button to turn on the projection lamp. A beam of light will be projected on the work piece for alignment.</p> <p>A solid yellow light bulb icon indicates the lamp has been turned on.</p> <p>Press again to turn the lamp off.</p> <p> The projection lamp automatically turns off within 90 seconds.</p>
14		Trim cut ON/OFF	<p>This selection button works with the AUTO cutting mode.</p> <p>When under AUTO mode and before proceeding with your automatic cutting jobs, select <input type="checkbox"/>+0 if you wish the first cut to be “trim cut” i.e. trimming the edge of your material without the cut being counted into the “finished cuts.”</p> <p>In the other hand, select <input type="checkbox"/>+1 if you do not need to trim cut the material. The first cut will then be counted as the first cut of your programmed jobs.</p> <p> After the first cut begins, you may still change your selection before the saw bow has descended to its lowest point.</p>
15		Saw blade speed adjusting speed (optional)	<p>: Press the dialogue box and enter the parameters to adjust the saw blade speed.</p> <ul style="list-style-type: none"> <li>• : Press this button to accelerate the saw blade.</li> <li>• : Press this button to decelerate the saw blade.</li> </ul>
16	 	Saw bow up indicator	<p>Indicates that the saw blade has risen to the point of touching upper limit switch.</p> <p>When activated, the saw blade icon will turn solid white.</p>



No	Item	Function	Description
17		Quick approach activating indicator	Indicates that the quick approach limit switch is engaging.  When activated, the saw blade icon will turn solid white.
18		Saw bow down indicator	Indicates that a cut is completed and the saw blade is at its lowest position.  When the blade completes each cut and triggers the lower limit switch, the saw blade icon will turn solid white.
19		Rear vise status indicator	Indicates if the rear vises have clamped and secured the workpiece.  When the rear vises have secured the workpiece, the clamping vise icon on the right will turn solid white.
20		Front vise status indicator	Indicates if the front vises have clamped and secured the workpiece.  When the front vises have secured the workpiece, the clamping vise icon on the right will turn solid white.
21		Feeding movement indicator	When the feeding vise reaches the front limit, the vise set icon will turn solid white.
22	<b>Blade Speed</b>	Blade speed display	Displays current blade speed.
23	<b>Cut rate</b>	Cutting rate display	Displays the current cutting rate.  <b>Cutting rate display is available only if the optional saw bow height decoder is equipped on the machine.</b>
24	<b>AMP.</b>	Blade cutting current display	Displays the current amplitude while the blade is running.
25	<b>Length</b>	Feeding length display	Displays current feeding length while the material is being fed.
26	 (yellow highlight)	Error message display	Displays error messages in the order of occurrences; press the message to clear the messages.
27		System parameter setting	Press this button to set up system parameters. Password is required.   All parameters have been set up by the

No	Item	Function	Description
			manufacturer. In order to prevent random change from being made to these parameters and affect cutting precision and machine life, this function is protected with a set of password.
28		Cutting program setting	Press this button to directly enter the cutting job program setup page.  A total of 100 cutting programs can be set.
29		Cutting status display	Press this button to display cutting-related information e.g. blade speed and blade life.  Information and parameter setups for optional accessories such as blade deviation detector can also be configured in this setup page.  Refer to Cutting Display & Setup in the following page.
30		Material cutting reference	This 2-page reference chart lists out the required blade speed and cutting rate for each different material.
31		PLC monitor	Shows current PLC signals.
32		Error report	Lists a historical report of the errors and the time of occurrence as well as provides troubleshooting support. 6 pages in total.

## Cutting program setup

When cutting is in operation, press  to quickly access the cutting program setup page.

JOB	length	Quantity	cut finished	HOME
00	<input type="text" value="0.0"/>	<input type="text" value="0"/>	<input type="text" value="0"/>	PgUp
01	<input type="text" value="0.0"/>	<input type="text" value="0"/>	<input type="text" value="0"/>	NEXT
02	<input type="text" value="0.0"/>	<input type="text" value="0"/>	<input type="text" value="0"/>	Cut Reset
03	<input type="text" value="0.0"/>	<input type="text" value="0"/>	<input type="text" value="0"/>	P01
04	<input type="text" value="0.0"/>	<input type="text" value="0"/>	<input type="text" value="0"/>	P06
				P11
Start Job	<input type="text" value="0"/>	End Job	<input type="text" value="0"/>	P16

### cutting program setup

- In this page you can set your desired cutting length and quantity and see the number of finished cuts (*Cut Finished*).
- A total of 100 cutting jobs can be set and performed under the automatic mode.
- In “Start Job” and the “End Job” field, fill in the number of the cutting job you wish to start and end with. The machine will automatically perform cutting jobs within this range.
- In *Length* column, set each respective cutting length in mm or inch.



## Notice:

1. 100 cutting jobs (job 00~99) is the Max Amount for the system to save; more than 100 jobs setting will start to cover the jobs from the first job of the HMI. (EX: If you set-up the 101th job, your first job( job 00) will be rewritten by the 101th job .)
2. The memory can keep 7 days without electric supply.

- In *Quantity* column, set each respective cutting quantity.
- Press **Cut Reset** button for 3 seconds to reset the cutoff quantity. If not reset, cutting will start with the unfinished job.
- Press **HOME** to return to the main control menu.
- Press **PgUp** to go back to the previous setup page.
- Press **NEXT** to go to the next cutting program setup page.
- Press **P01**, **P06**, **P11**, **P16** to quickly jump between cutting programs (Step 00 ~ 99).

NEXT

## Cutting status display & setup

When cutting is in operation, press **NEXT** to enter cutting status display and setup page.

Height	0.0	mm			HOME
length	0.0	mm			NEXT
Cut Speed	0.0	mm/min			HP Scr.
Blade Speed	0.0	m/min			
DEVIATION	0.00	mm			
AMP.	0.0	A			
Cut rate	0.0	cm2/min			
JOB	0	SET NO.	0	FINISH NO.	0

### Page 1 – cutting status display

This page shows the following information (from top to bottom):

- The height of the saw bow



This function is available only if the optional height decoder is equipped with the machine.

- Feeding length (current feeding vise position)
- Current blade descending speed



This function is available only if the optional height decoder is equipped with the machine.

- Current blade speed
- Deviation value (optional)



This function is available only if the optional blade deviation detector is equipped with the machine.

- Present electric current in ampere (optional)



Not shown if the machine comes without this option.

- Current cutting rate
- Number of current cutting job/step in operation
- Preset quantity of current cutting job
- Number of cuts finished
- Error messages (highlighted in yellow; can be cleared by pressing down)
- Press **HOME** to return to the main control menu.
- Press **NEXT** to go to the next setup page.
- Press **HP Scr.** to go to V-Driver page(optional). HP Scr.

is displayed when cutting . V-Driver mainly increases cutting rates and decreases cutting vibration.

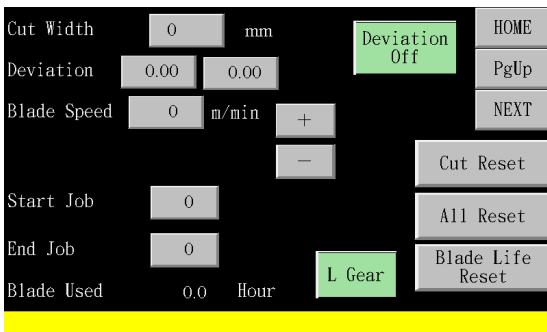

## Page 2 – Cutting status setup

The operator can set different values according to the material properties.

- **Cut Width** - Press this button to set your workpiece width. (Available only when the machine is equipped with the optional height decoder)
- **Deviation** - Set deviation tolerance value (left: positive; right: negative) based on the precision requirement of your material. During cutting, if the blade deviation is greater than the set values, the saw blade will be stopped to protect the blade.
- **Deviation On/Off** - Turn on or turn off the deviation detector if installed. (Available only when the machine is equipped with the optional blade deviation detector).
- **Blade speed** - Press this key to adjust the blade speed according to the material being cut. **+** - Press this key to increase the blade speed. **-** - Press this key to decrease the blade speed.



The operator must make sure the pulley is at high or low gear. Speed range = 15~115 M/min.



Not shown if the machine comes without this option.

- **Start Job**, **End Job** - In “Start Job” and the “End Job” field, fill in the number of the cutting job you wish to start and end with. The machine will automatically perform cutting jobs within this range.
- **Blade Used** - Current blade life in hours.
- **L Gear** - Press this key to switch between low (L) and high (H) gears for the drive belt.



**Maximum blade speed on L Gear: 72 M/min; On H Gear: 115 M/min.**



Not shown if the machine comes without this option.

- Error messages (highlighted in yellow; can be cleared by pressing down)

- Press **Home** to return to the main control menu.
- Press **PGUP** to go back to the previous setup page.
- Press **NEXT** to go to the next setup page.
- **Cut Reset** - Reset all *Cuts Finished* data by pressing this button for three seconds.
- **All Reset** - Reset all preset cutting data within *Starts Step* and *Ends Step* by pressing this button for three seconds.
- **Blade Life Reset** - Reset the blade life to zero

STEP	length	Quantity	cut finished	HOME
00	0.0	0	0	PgUp
01	0.0	0	0	NEXT
02	0.0	0	0	Cut Reset
03	0.0	0	0	P01
04	0.0	0	0	P06
				P11
Start Step	0	End Step	0	P16

## Page 3 – Cutting program setup

Same as previously described cutting program setup.

## **Mtrl** Material cutting reference

THE TABLE OF CUTTING RANGE (JIS)			HOME
MATERIAL	BLADE	CUTTING RATE	
01 S20C-S35C	65 - 90	70 - 108	
02 S40C-S50C	65 - 90	70 - 100	
03 S9CK-S15C	80 - 110	60 - 90	
04 S53C-S58C	65 - 90	60 - 80	
05 SS50	65 - 90	60 - 70	
06 SS41	65 - 90	55 - 70	
07 SM50	54 - 50	50 - 56	
08 SCM3	54 - 80	65 - 80	
09 SUP5	54 - 80	40 - 55	
10 SRC.3.4	54 - 80	40 - 55	
11 SCMM22	54 - 80	40 - 50	
12 SNC1	54 - 80	40 - 50	
13 SNC22	54 - 80	35 - 45	
14 SNCMM22	54 - 80	35 - 45	

This 2-page reference chart lists out the required blade speed and cutting rate for each different material. Both Metric and Imperial.

- Press **Home** to return to the main control menu.
- Press **NEXT** to go to the next setup page.
- Press **Inch** or **Metric** to switch unit.

Feed and speed selection Bi-Metal						HOME
Material	Blade Speed (FPM)	Sq. In. Per (Min)	Material	Blade Speed (FPM)	Sq. In. Per (Min)	
1008-1035	320	15	9255-9262	190	4	
1090-1084	230	8	9310-9317	165	3	
1085-1095	190	6	9437-9550	210	5	
1513-1536	330	16	Tool Steels			
1541-1572	330	8	A2, A3, A8, A9	190	4	
Free Machining Carbon Steels			A4-A6	160	4	
1103-1192	330	16	A7, A10	80	4	
1137-1151	260	9	D2, D5	100	3	
1212-1213	340	16	D3, D4	85	3	
Carbon Alloy Steels			D7	75	1.5	
1320-1345	210	8	D1, D2	200	6	
3115-3150	235	9	D6, D7	180	7	
3110-3315	210	5	H10-H14	190	5	
4017-4042	275	7	H21-H42	185	4	
4130-4150	250	7	L2, L6	185	6	
4317-4340	225	6	L7, S1	190	5	
4608-4621	220	6	M1	140	4	
4812-4820	190	4	M2, M3	110	3	
5045-5135	240	8	M4, M10, M15, M41-M47	85	2	
5140-5150	230	6	M6, M7	120	4	
50100-50100	145	5	M30-M36	100	2	
6117-6152	220	6	T1, T2	120	3	
8615-8645	220	7	T4, T5	100	2	
8647-8660	190	4	T6	90	2	
8715-8750	230	6	T8	75	2	

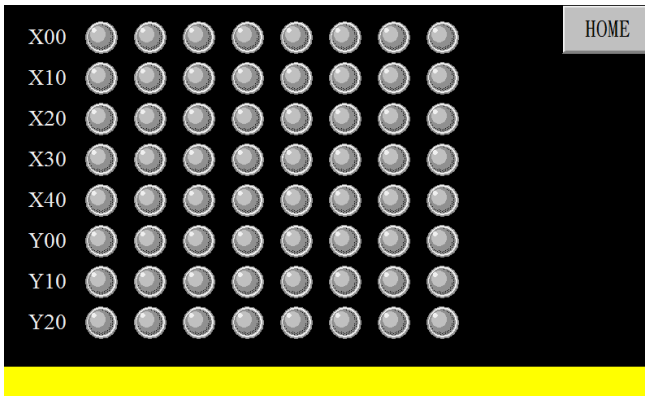

Shows all signals of the PLC system.



**Page 1 – error report**

- Lists a historical report of the errors and the time of occurrence.
- Press **HOME** to return to the main control menu.
- Press **NEXT** to go to the troubleshooting support page.
- Press **Err Reset** to clear the error messages so the error messages will be erased the next time when the machine is restarted.

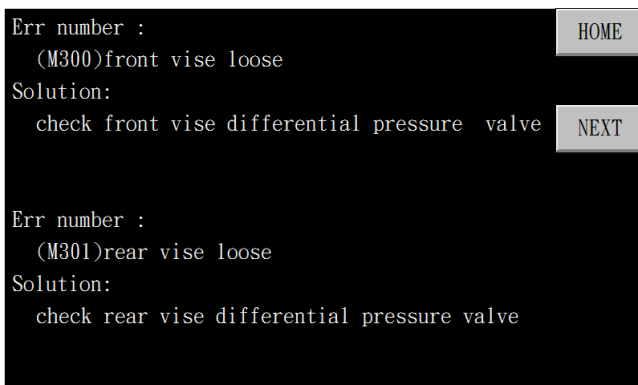

**Page 2 – troubleshooting**

- Provides suggestions on troubleshooting. 6 pages in total.
- Also refer to the below table for error codes, descriptions and solutions.
- Press **HOME** to return to the main control menu.
- Press **NEXT** to go to the troubleshooting support page.

<b>Error Code</b>	<b>Error Description</b>	<b>Solution</b>
M300	Front vises not clamping	Check if the queen valve works
M301	Rear vises not clamping	Check if the queen valve works
M303	Lower limit switch error	Check if the lower limit switch works
M304	Hydraulic motor not starting	Check if the hydraulic motor works
M306	Broken blade detected	1. Check the blade motion detector01 2. Check if the blade is broken
M308	Left safety door abnormal	1. Check if the left safety door is shut properly 2. Check if the left safety door limit switch works
M309	Right safety door abnormal	1. Check if the right safety door is hut properly 2. Check if the right safety door limit switch works
M312	Quick approach bar abnormal	Check if the quick approach limit switch works
M313	OL1 abnormal	Check if the blade motor overload relay has tripped
M314	OL2 abnormal	Check if the hydraulic motor overload relay has tripped
M315	OL3 abnormal	Check if the coolant pump motor overload relay has tripped
M316	Saw bow upper limit abnormal	Check the upper limit switch works
M352	Front vise clamping error	1. Place new material 2. Check if the vise queen valve works 3. Check if the “no material parameter” is too low
M357	Saw bow descending error	1. Check if the descend solenoid valve is stuck 2. Check the quick approach bar works 3. Check if the quick approach bar limit switch works
M358	Saw bow ascending error	1. Check if the ascend solenoid valve is stuck 2. Check the quick approach bar works 3. Check the quick approach bar limit switch works
M361	No material	1. Place new material 2. Check if the vise queen valve works 3. Check if the “no material parameter” is too low
M363	PLC battery voltage too low	Replace PLC battery

## STANDARD ACCESSORIES

### Blade tension device

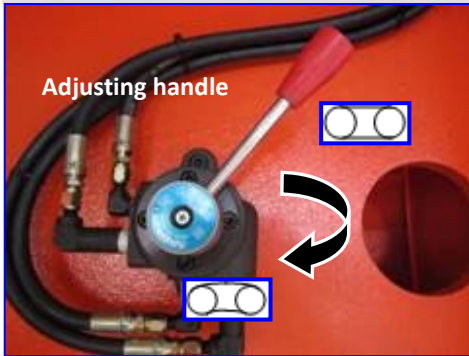

- This blade tension device equipped with hydraulic cylinder provides appropriate tension to the saw blade.
- To tighten the saw blade, turn the selector to
- Upon saw blade breakage, the safety device will activate and automatically stop all machine operation.
- The limit switch of the safety device can be reset by turning the blade tension selector to
- To change the blade, turn the handle to to release saw blade tension.



Never adjust blade tension while the blade is running.

### Blade speed/motion detector

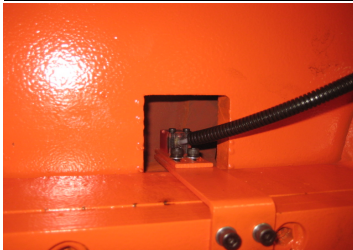

- Besides detecting the blade speed, the speed/motion detector also functions as a safety device.
- The speed/motion detector protects operators and the machine by preventing blade overloads and consequent damages if a saw blade breaks or skids.
- Once blade breakage or slippage is detected, the drive wheel will stop in 10 seconds.

### Gear reducer

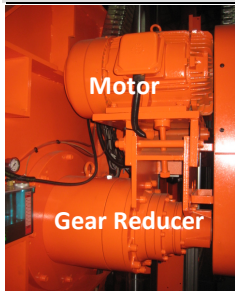

The gear reducer is specially designed to produce high output.



Refer to Section 8 for the maintenance of the gear reducer.

### Inverter



This inverter is installed inside the machine base. It is used to control and stabilize the saw blade speed during cutting.

To adjust blade speed, use the speed control turn-knob on the control panel.



Voltage used should not exceed AC 640V.



*Note:*

1. Make sure the terminal points are connected.
2. Make sure the ambient temperature is within acceptable range and keep the surroundings well ventilated.
3. Keep the inverter away from dust.
4. For repair or maintenance, please contact your local agent.



## Quick approach device

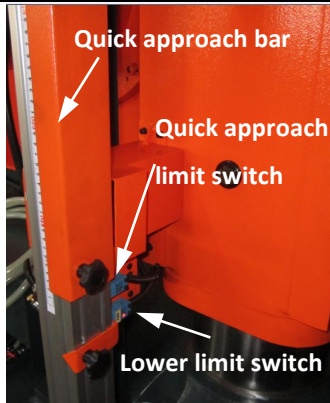

This device allows the blade to quickly descend to just right above the material to save you operation time.

Adjust the quick approach bar according to the workpiece height. Generally speaking, the lowest end of the quick approach bar (painted orange) should be about 10 to 20 mm above the material. This way when the limit switch contacts with the quick approach device, the saw bow can quickly descend and then as soon as the limit switch leaves contact with the quick approach bar, the saw bow slows down to be ready for cutting.

## Vibration damper

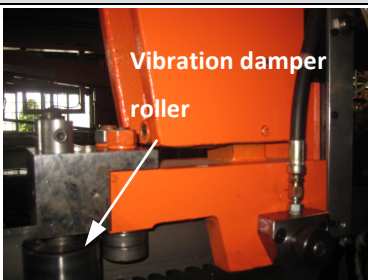

Vibration damper roller is installed on the left saw arm. It reduces the high frequency noise while cutting large work piece.

## Large main shaft lubrication manual pump

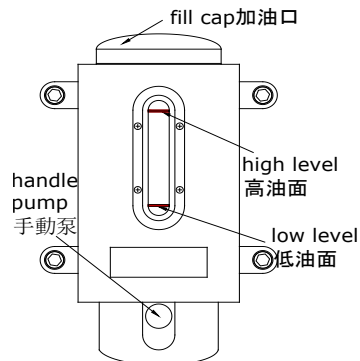
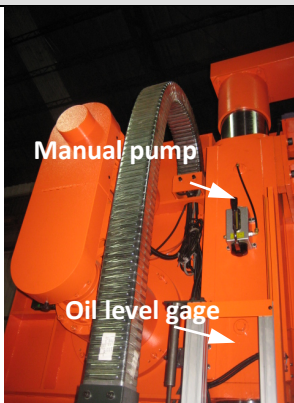

This device only provides lubrication to the main shaft. This device uses #90 lubricant or select appropriate lubricant according to the local climate condition.



Check every week to see if the oil level has dropped to low level. Use the manual pump to add lubricant until it reaches the high level at the gauge.

## Hydraulic powered wire brush

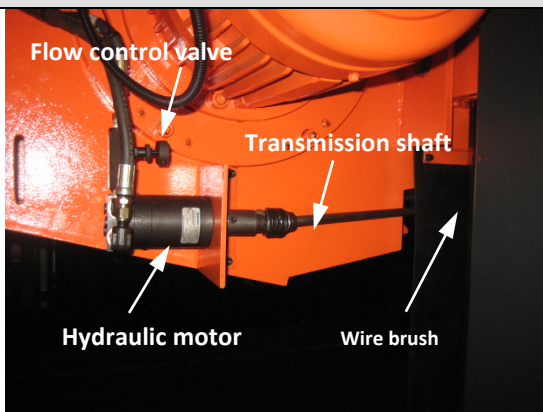

The wire brush is hydraulically driven to rotate at the same speed as the blade motor. It removes the metal chips on the saw blade teeth so that blade life can be extended.



Keep hands away from the transmission shaft and the brush while the wire brush is running.



Turn off the hydraulic motor or the main power switch before performing maintenance or cleaning on the wire brush drive system.

## Middle limit switch

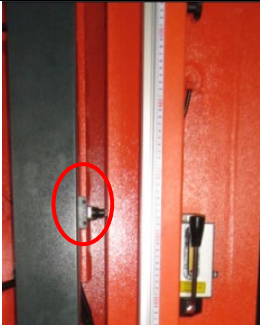

The bracket on the side of the main shaft sets the middle limit switch on while the blade is running. At this time, guide arm cannot be moved and front vise can open be opened in small increments.

## Projection light



Activate the switch to project a beam of light on the work piece. The operator can use the light as reference to adjust the cutting dimension of the work piece. The light will shut off automatically within 90 seconds.

## Coolant pump

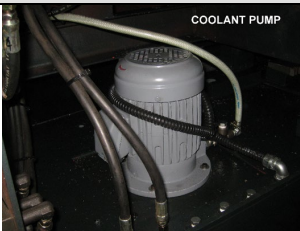

The coolant pump supplies coolant to reduce temperature at cutting area. It can also be operated independently from the control panel and works with cleaning hose for machine cleanup.

## Blade tension control device

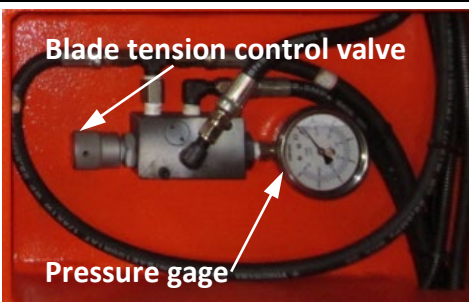

This pressure control valve adjusts blade tension. The blade pressure is normally set between 45 to 50 kg/cm<sup>2</sup> depending on the cutting condition.



A blade tension set too high or too low will affect blade movement and consequently shorten blade life.



Never adjust blade tension during cutting.

## Hydraulic oil level gauge



- The level of hydraulic oil remaining in the tank can be easily read from the gauge.
- Refill hydraulic oil and maintain it at an appropriate level (between 1/2 and 2/3 level as seen from the gauge).
- Hydraulic oil shortage will cause hydraulic system abnormality and affect the cutting operations.

## OPTIONAL ACCESSORIES

### Blade deviation detector



This device detects blade deviation. If the blade deviates beyond the preset range, the machine will stop automatically. When this device is installed, the cutting width will be reduced. The blade deviation detected value and preset values are displayed on the control panel screen.

### Saw blade spray device

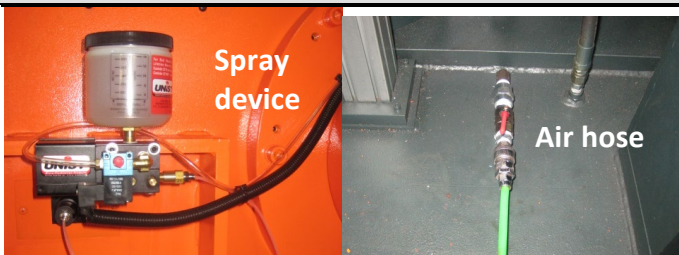

This optional device is specially designed for cutting aluminum. The operator can activate the spray device from the control panel. When activated, the device will spray oil mist at specific time intervals to clean the remaining chips off the blade.

### Height decoder

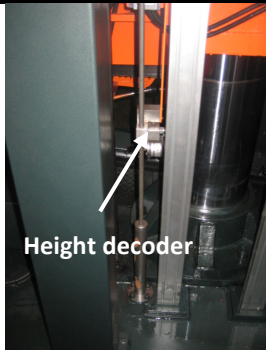

With this optional device, the operator can input work piece width via HMI touch panel. When cutting begins and the blade starts to descend, the panel will display the current blade height, the blade descend speed and the cutting rate calculated by the system.

### Vise / top clamp pressure regulators



These regulators control the clamping pressure for the vises and the top clamps. When cutting pipes or softer materials, the clamping pressure of the vises and top clamps need to be adjusted to avoid damages to the material surfaces. Adjust the clamping pressure according to the material you cut.



Do not adjust clamping pressure during operation.



The clamping pressure shall not be less than 8 kg/cm<sup>2</sup>.

## Chip conveyor

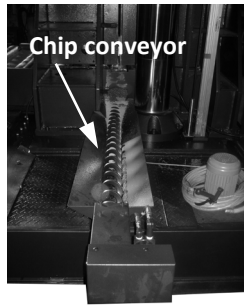

Chip conveyor

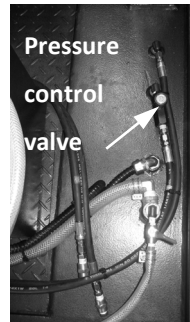

Pressure control valve

Chip conveyor is a spiral device to bring chips out during cutting.



Keep hands away from the chip conveyor assembly. Chip conveyor begins to operate as soon as the hydraulic motor is turned on.



As a regular maintenance, remove the chip conveyor and clean all chip deposits inside.



For your safety, be sure to turn off the hydraulic motor or the power during maintenance or cleaning.

## Top clamp

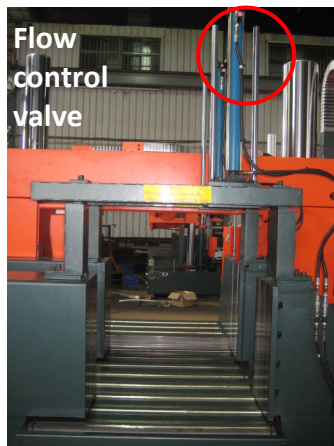

Flow control valve

The top clamp device is used for bundle cutting and is composed of two clamps, which are to be installed on top of the front and rear vises respectively.

When the vises clamp or unclamp the material, the top clamp will act accordingly. With top clamp, bundle cutting can be achieved smoothly and steadily.

When not in use, simply turn off the flow control valve on top of the hydraulic cylinder (left indicated).

## 3M powered roller table



- The optional 3M powered roller table supports the work material and ensures the material be fed in smoothly.
- Refer to Section 9 for further information on adjusting the roller table.

## 3M powered roller table – power terminal



POWER ROLLER TABLE ELECTRICITY CONNECTOR

POWER ROLLER TABLE HYDRAULIC CONNECTOR

- The power terminal for the 3M powered roller table is located under the workbed. It is used to supply the power to the roller table.
- Designed to be water-proof and easy to assemble.



Please do not make any change to the type of terminal.

### 3M powered roller table – remote control



With this remote control, you can choose to operate the roller table independently or synchronize the rollers with the movement of workbed vises. You can use the remote control to feed the material both forward and backward. The feed speed selection switch also allows users to quickly and accurately feed the work pieces to the cutting area.

### UNROLLING & INSTALLING THE BLADE



Always wear leather gloves and protection glasses when handling a blade.

#### Unrolling the blade

Please follow the procedures illustrated below.

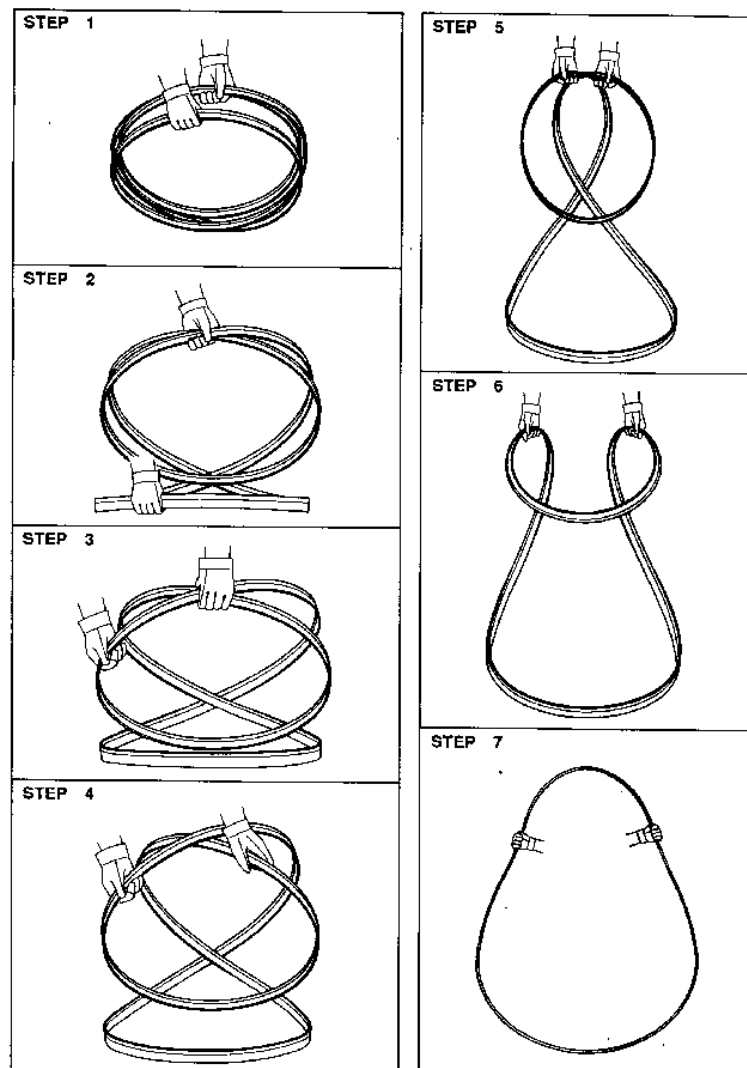

## Installing a new blade

Step 1 - Select the most suitable saw blade for your workpiece considering the size, shape and material.

Step 2 - Turn on the machine power by switching to *ON* and turn on the hydraulic system.

Step 3 - Switch to *manual* (🖱️) mode.

Step 4 - Press the *saw bow up* button and elevate the saw bow to an appropriate height.

Step 5 - Turn the saw blade tension adjusting handle from "🔸🔸" to "🔹🔹" position (shown below) to move the idle wheel close to the drive wheel.

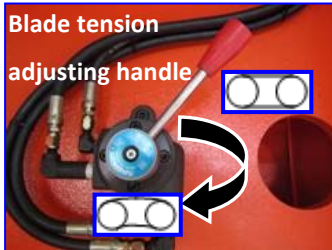

Step 6 - Open the drive and idle wheel covers.



Step 7 - Loosen the wire brush lock lever, and lower the wire brush.



Step 8 - Loosen the left and right carbide inserts. Detach the old blade from below the left and right guide seat and then pull the entire blade out.

Step 9 - If necessary, clean the carbide inserts before installing a new saw blade.

Step 10 - Place the new blade around the idle wheel and the drive wheel.

Step 11 - Insert the blade into the left and right tungsten carbide inserts. The back and the sides of the blade need to be touching the inserts as well as the adjacent rollers.

Step 12 - Place the blade to the drive wheel and press the back of the blade against the flange of the drive wheel.

Step 13 - Make sure the back of the blade is also pressed against the flange of the idle wheel.

Step 14 - Turn the tension controller handle to [🔹🔹] position to obtain blade tension.

Step 15 - Make sure the sides of the blade are in close contact with the carbide inserts and then tighten the left and right carbide inserts.

Step 16 - Gently close the idle and drive wheel covers.

Step 17 - Press the *saw blade start* button to start the blade. Allow the blade to run for a few rotations then press the *saw bow up* button to elevate the saw bow. Open the wheel

covers and make sure the blade has not fallen off the drive and idle wheels. If the blade has shifted, follow the same procedure to reinstall the blade again.

Step 18 - Adjust wire brush to a proper position. Refer to *Adjusting wire brush* in this section.

## ADJUSTING WIRE BRUSH

Follow these steps to adjust wire brush to appropriate position:

Step 1 – Loose the wire brush lock lever.

Step 2 – Manually move the wire brush so that it properly contacts with the saw blade teeth (see below illustration).

Step 3 – Tighten the lock lever to lock the wire brush in position.

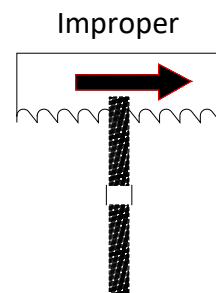
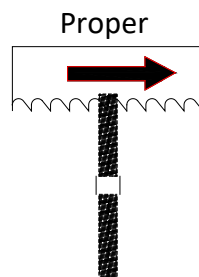

## ADJUSTING SAW ARM

Adjust the blade guide (guide arm) position based on the size of your workpiece:

Step 1 – Loosen the carbide inserts by pressing *carbide inserts unclamp* button on HMI touch screen.

Step 2 – Utilize the two buttons, *guide arm to the left* and *guide arm to the right*(for non-CE model), or the guide arm left/right switch(for CE model), to adjust guide arm positions.

Step 3 – After adjustment is made, clamp the inserts back by pressing *carbide inserts clamp* button on HMI touch screen.



Be sure that the guide arm will not bump into the front vise, set the guide arm width according to the scale on top of the sliding board.

## PLACING WORKPIECE ONTO WORKBED

Step 1 – Press the *saw bow up* button and elevate the saw bow until it reaches to its highest point.

Step 2 – Press the *front vise open* and *rear vise open* buttons to open vises.

Step 3 – Carefully place the workpiece onto the work feed table to where it extends approximately 30mm(1.2 inch) beyond the rear vise toward the front vise.

## POSITIONING WORKPIECE FOR CUTTING

Follow these steps to position your workpiece:

Step	Action
rear vises clamp material	<b>1</b> Press the <i>rear vise clamp</i> button until the workpiece is securely clamped.
align vertical rollers	<b>2</b> Move the vertical alignment rollers toward workpiece until it stands against the workpiece. Lock the vertical alignment rollers by tightening the lock handles
feed material forward	<b>3</b> Press the <i>feed forward</i> button until the rear vise touches the front limit switch.
front vises clamp material	<b>4</b> Press the <i>front vise clamp</i> button until the workpiece is securely clamped.
rear vises retract to clamp material again	<b>5</b> Press the <i>rear vise open</i> button.
	<b>6</b> Press the <i>feed backward</i> button until the rear vises reach back limit switch.
	<b>7</b> Press the <i>rear vise clamp</i> button until the workpiece is securely clamped again.
front vises open; prepare for precision position	<b>8</b> Press the <i>front vise open</i> button and the <i>rear vise clamp</i> button simultaneously.
confirm cutoff point	<b>9</b> Press the <i>saw bow down</i> button to lower the saw bow until the quick approach bar descends to just about 10mm (0.4 inch) above the workpiece.   Under no circumstances should the quick approach bar be lowered below the height of the workpiece.
precision position	<b>10</b> Press the <i>feed forward</i> button (and the <i>feed backward</i> button if necessary) until the cutoff point on the workpiece aligns with the blade line.
front vises clamp material; ready to cut	<b>11</b> After the workpiece is correctly positioned, press the <i>front vise clamp</i> button so the workpiece is securely clamped.

## ADJUSTING BLADE SPEED

Step 1 – Set the flow control to “0” position.

Step 2 – Press the *saw blade start* button to start the blade.

Step 3 – Turn the *blade speed control knob* to adjust the blade speed. The blade speed should be adjusted based on the size and the material of the workpiece.



## ADJUSTING COOLANT FLOW

Step 1 – Press the *saw blade start* button to start the saw blade drive motor.

Step 2 – Press the *saw bow down* button to lower the saw bow.

Step 3 – Use the coolant flow control valve (shown below) to adjust the amount of fluid flowing to the cutting area.



Adjust the flow amount if you observe the following changes to the chips generated from cutting.

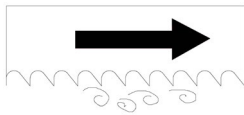

If the chips are sharp and curved, increase the coolant flow amount.

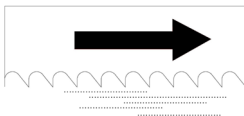

If the chips are granulated, decrease the coolant flow amount.

## BREAKING-IN THE BLADE

When a new saw blade is used, be sure to first break in the blade before using it for actual, extended operation. Failure to break in the blade will result in less than optimum efficiency. To perform this break-in operation, the following instructions should be followed:

Step 1 - Reduce the blade speed to one-half of its normal setting.

Step 2 - Lengthen the cutting time to 2-3 times of what is normally required.

Step 3 - The complete break-in operation requires cutting on a 645 mm<sup>2</sup> (25.4 square inches) section for 5 times.

Step 4 - After the break-in operation is completed, set all parameters back to normal settings.

## TEST-RUNNING THE MACHINE

Test-running this machine can ensure good machine performance in the future. We suggest you run the following tests on the machine before first use:

### Testing machine performance:

Turn on the power and run a basic performance test after you finish installing the machine. Follow these steps to test machine performance:

Step 1 – Disassemble shipping brackets and bolts.

Step 2 – Install roller table (optional).

Step 3 – Turn on the relay switch in the control box.

Step 4 – Elevate the saw bow. (If your coolant pump is in reverse and the machine cannot run, please change the electrical phase.)

Step 5 – After the saw bow ascends, extend the quick approach device.

Step 6 – Remove the rust-prevention grease with cleaning oil or kerosene.

Step 7 – Start the coolant pump.

Step 8 – Test these functions under manual mode:

- vise clamping/unclamping
- saw bow ascending/descending
- feeding forward and backward.

## CUTTING OPERATION

Step 1 – Check before you cut

- **Power:** Check the voltage and frequency of your power source.
- **Coolant:** Check if you have sufficient coolant in the tank.
- **Hydraulic:** Check if you have sufficient (at least two-thirds or higher) hydraulic oil.
- **Workbed:** Check if there is any object on the feeding bed that may cause interference.
- **Blade:** Check the blade teeth and make sure there is no worn out teeth along the blade.
- **Light:** Check the work lamp or laser light (optional) and make sure there is sufficient lighting.
- **Roller:** Check all the rollers on the front and rear workbed can roll smoothly.
- **Saw bow:** Check the saw bow to see if it can be elevated and lowered smoothly.

Step 2 – Place your workpiece onto the workbed manually or by using a lifting tool e.g. a crane.



Before loading, make sure the vises are opened to at least wider than the width of the workpiece.

Step 3 – Position your workpiece.

Step 4 – Clamp the workpiece.

Step 5 – Adjust *blade descend speed control* knob to obtain a suitable blade descend speed for your material.

Step 6 – Start running the blade.



Before you start cutting, check again that there is no other object in the cutting area.

Step 7 – While the blade descends, adjust the blade speed if necessary. You can do so by turning the *blade speed control* knob, clockwise to speed up and counterclockwise to slow down. The blade speed is displayed in the HMI touch screen.

Step 8 – Select the proper cutting condition according to different material.

Step 9 – After the entire cutting job is completed, elevate the saw bow to the top and open the vises to remove the workpiece.

Step 10 – Clean the workbed by removing chips and cutting fluids.

Step 11 – Lower the saw bow to a proper position then turn off the power.

## **STARTING AN AUTOMATIC OPERATION**

Step 1 – Use manual mode and cut the edge of the workpiece by using the same procedures as those described under manual operation.

Step 2 – After the trim cut is completed and the saw blade has stopped at the lower limit position, press the *saw blade up* button to raise the saw bow and adjust the quick approach bar until it is approximately 10mm (0.4inch) above the workpiece.

Step 3 – Turn the *Auto/manual* switch to manual.

Step 4 – Set your desired cutting length and quantity via the HMI touch screen. A total of 100 sets of cutting data can be programmed.

Step 5 – Turn the *Auto/manual* switch to Auto.

Step 6 – Press the *saw blade start* button and press the *saw bow down* button to start automatic cutting.

## USING TOP CLAMP FOR BUNDLE CUTTING



**Before Cutting , Make sure that the bundle is properly tightly clamped but not being distorted by clamp force.**

**Any improper bundle cutting can cause damage to the blade, reduce the blade life.**

**Notice:** There are several factors to makes bundle cutting more difficult and unstable, such as vibration, wide guide spacing, coolant getting to the teeth and cutting through work hardened chips.

1. Each bar of the bundle is suggested to be the same size for being firmly clamped in the bundle.
2. Make sure that the bundle is properly placed (before cutting) to refrain from vibration, spinning and changing length position during cutting.
3. Tack welding ends of bars will prevent spinning but not vibration.

### Installing top clamp

To perform bundle cutting, use the top clamps and take the following installation procedures.

Step 1 – Install stud bolts on the front and rear vises and position the top clamp.

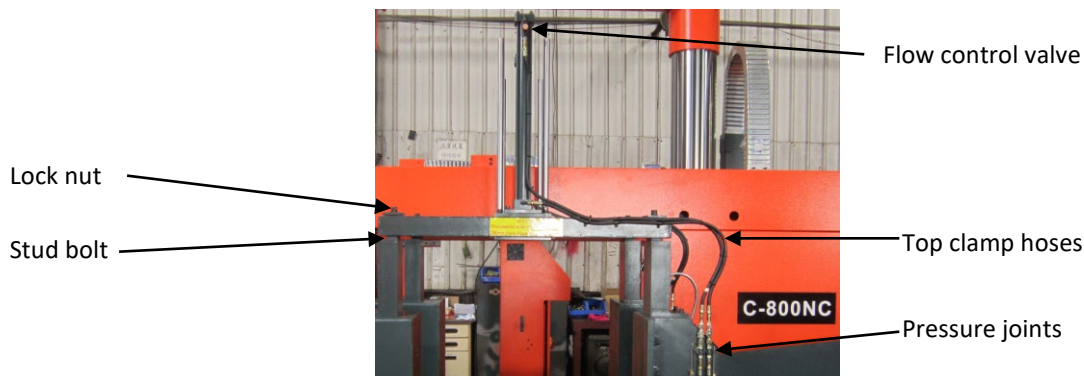

Step 2 – Connect the top clamp hoses to the pressure joints on the vise hydraulic cylinders.

Step 3 – Turn on the flow control valves for front and rear top clamps, and make sure the top clamps clamping timing are the same as vises clamping.



It is not necessary to work with top clamps while single cutting. Turning off the control valve and removing the clamping bracket in order to make the saw blade run smoothly are acceptable.

Step 4 - Position the workpiece for bundle cutting.



Note the allowable clamping width and height. (Refer to *Section 2 – General Information, Specifications.*) If the material width is narrower than 280mm, please disassemble the top clamp.

### Proper and improper stacking of workpieces

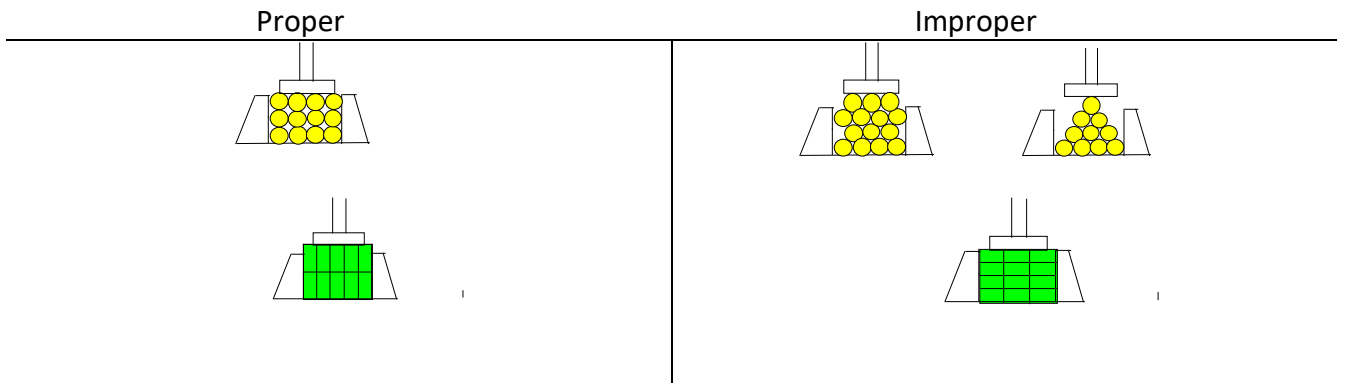

- Step 5 – Align the top clamp cylinders with the center of the workpiece and tighten the lock nuts.
- Step 6 – Press *Single/Bundle cutting mode* button and switch to bundle cutting mode.
- Step 7 – For subsequent cutting procedures, refer to the instructions under manual operation and automatic operation.

### Uninstalling top clamp

Follow these steps to uninstall top clamp for cutting single material:

- Step 1 – Disconnect the top clamp hoses.
- Step 2 – Loosen the lock nuts and remove the top clamp.
- Step 3 – Remove the stud bolts.



### **TERMINATING A CUTTING OPERATION**

- To terminate a cutting operation, press either the *saw bow up* button or the *emergency stop* button.
- The saw blade will stop running when the *saw bow up* button is pressed.
- Both the saw blade and hydraulic pump motors will stop running when the *emergency stop* button is pressed.
- The machine will stop automatically when an error occurs. The error message will be shown on the screen.

Section 5

# *ELECTRICAL SYSTEM*

**ELECTRICAL CIRCUIT DIAGRAMS**

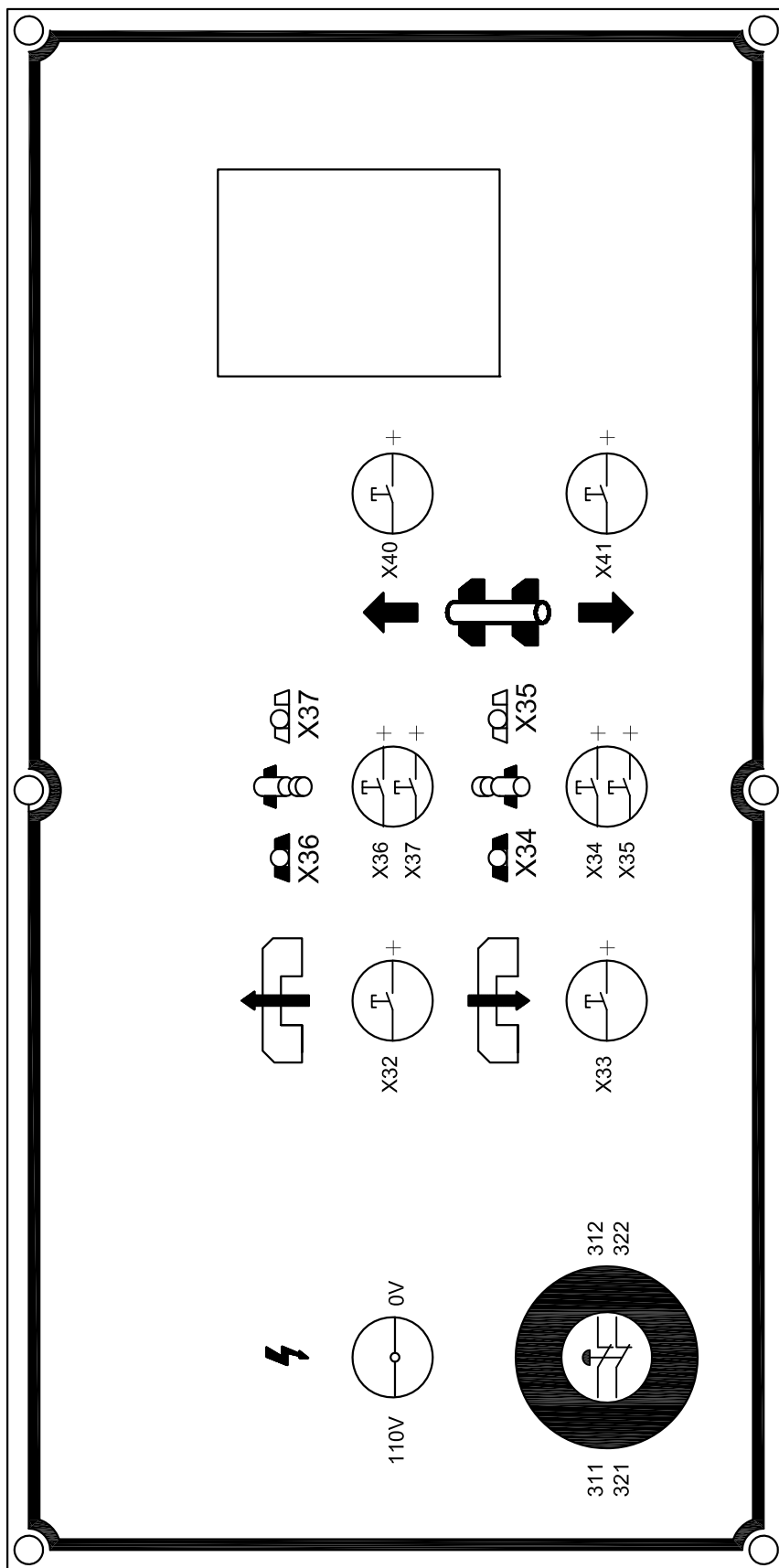

TB-1

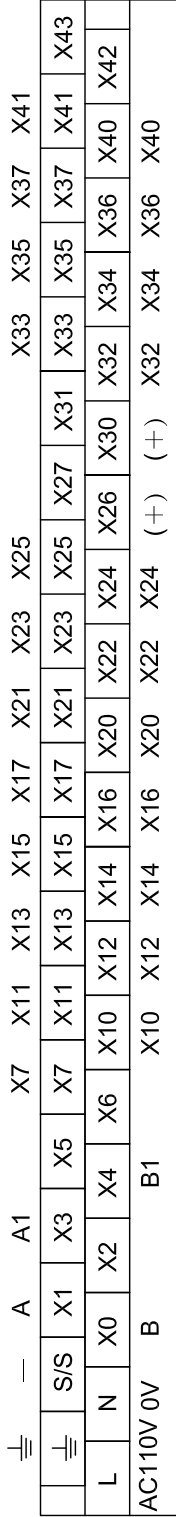
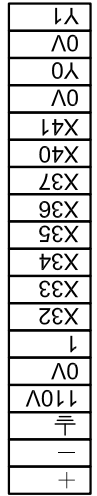

# PLC FX3G-60M

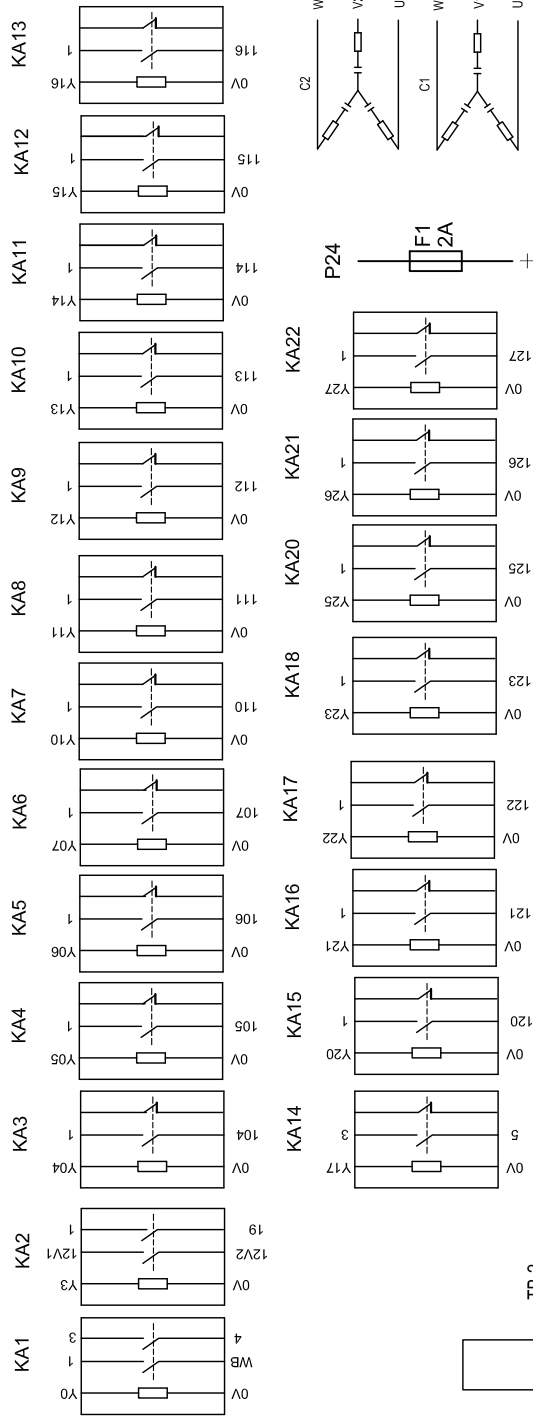
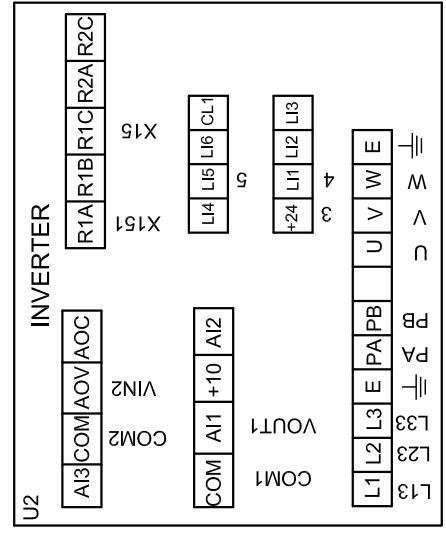
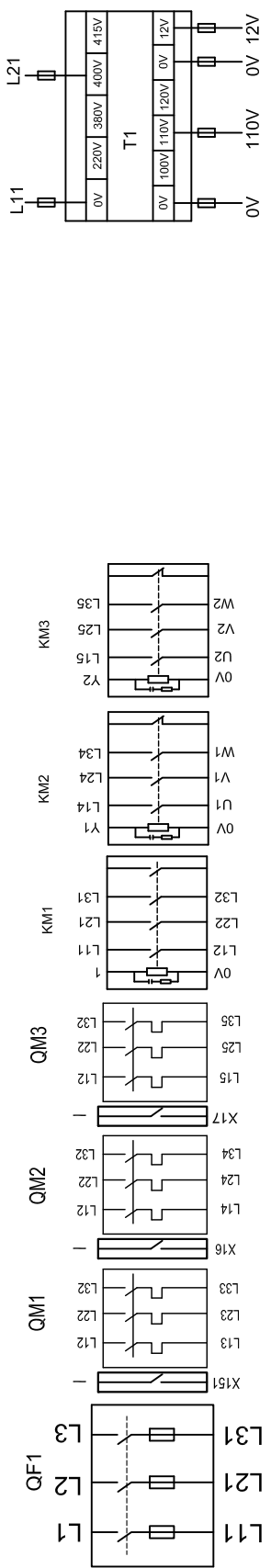
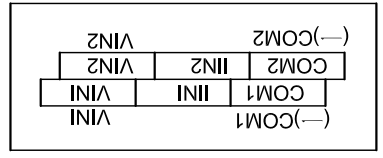
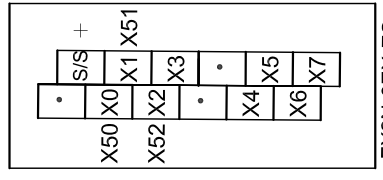
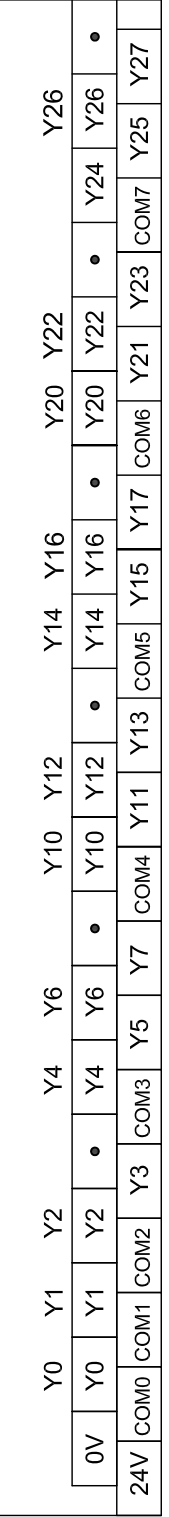

TB-2

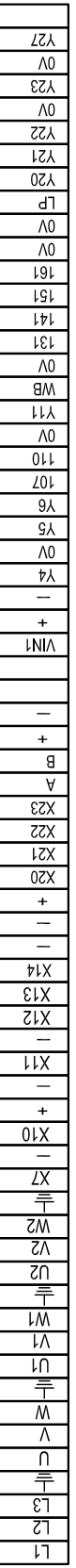



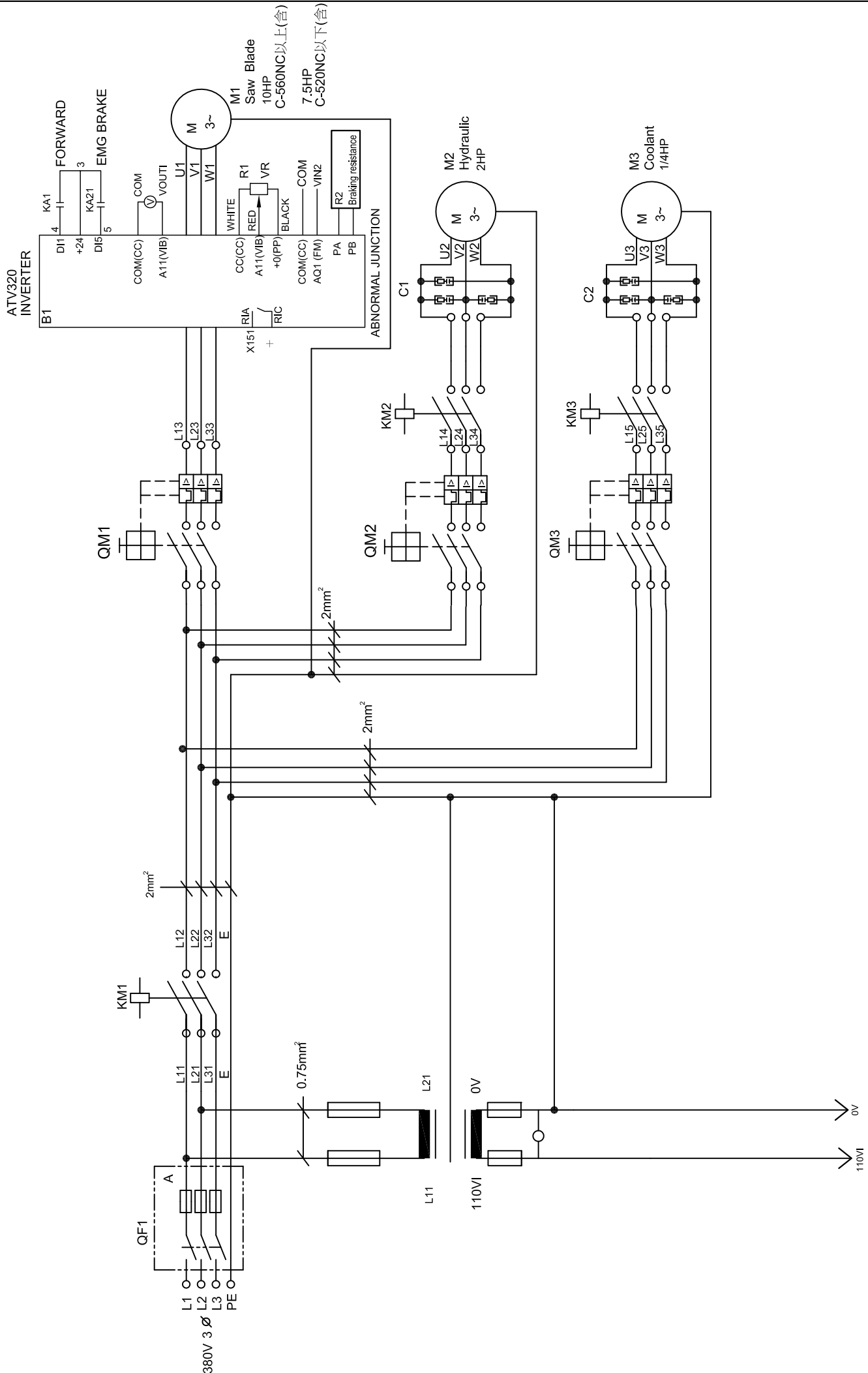

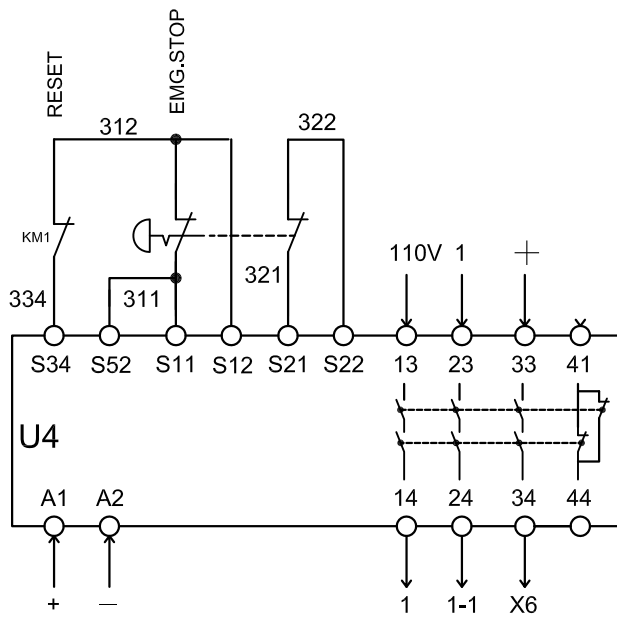
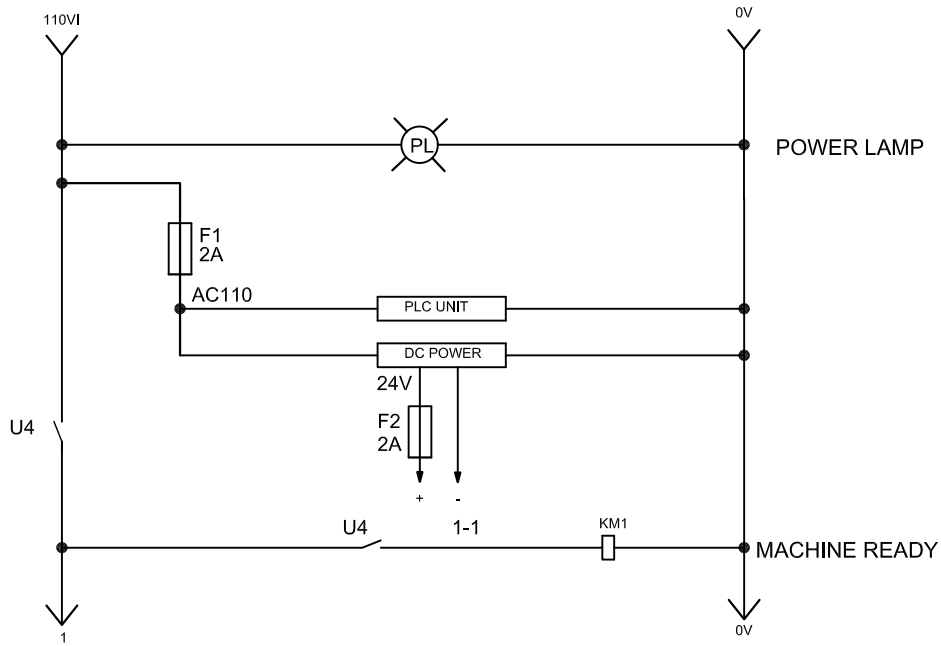

to encoder

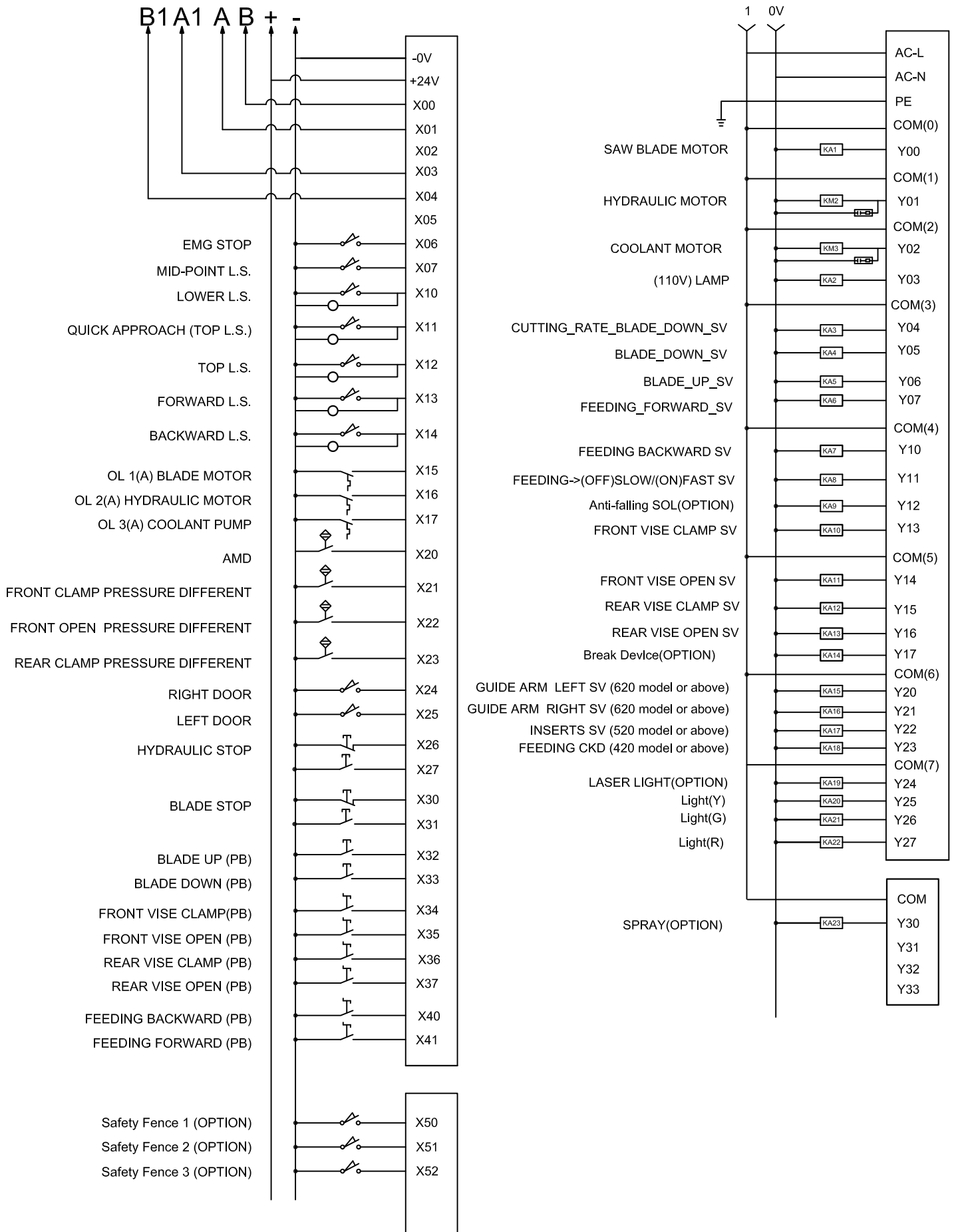

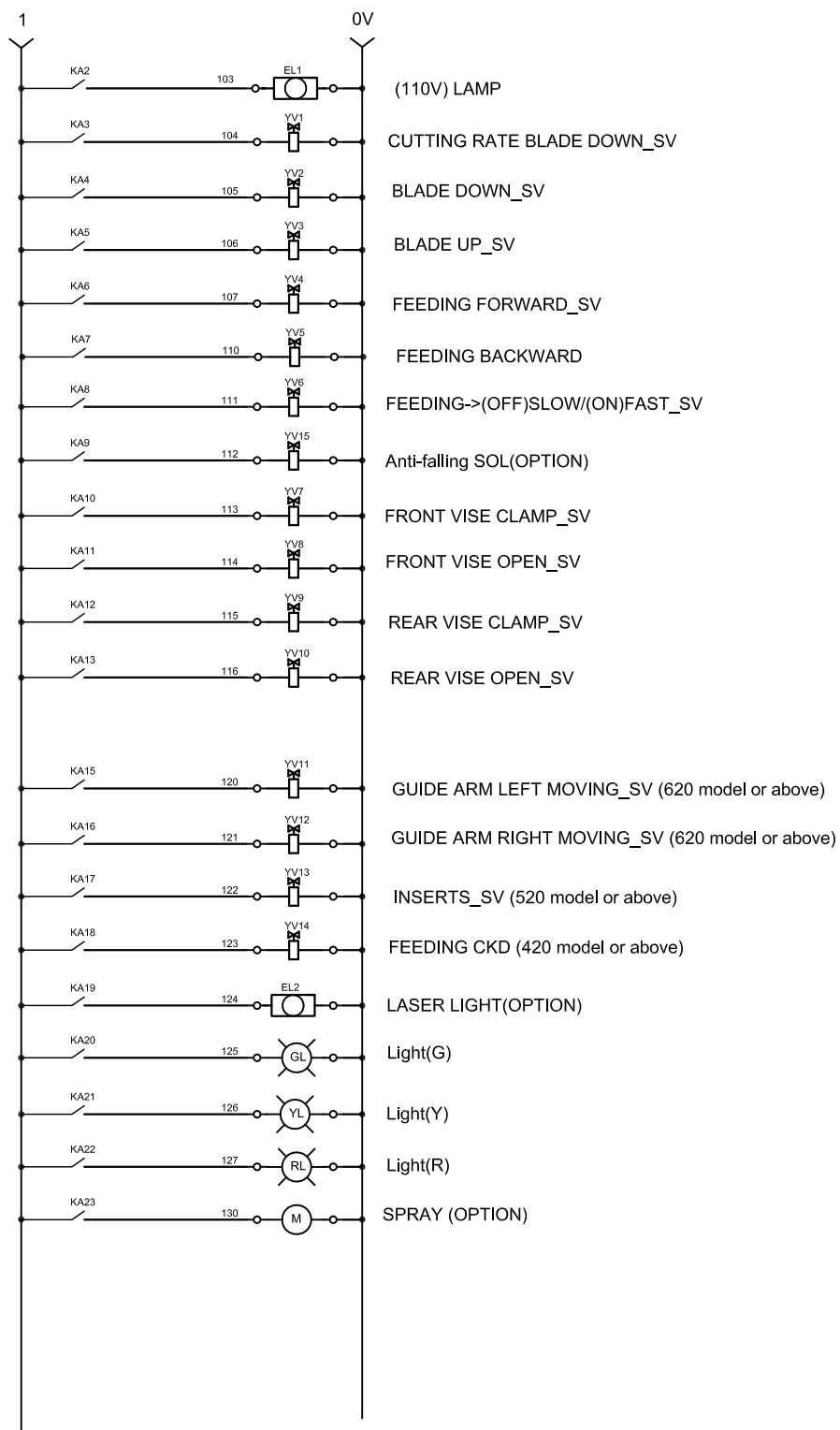

# *HYDRAULIC SYSTEM*

## **HYDRAULIC CIRCUIT DIAGRAMS**

The following are hydraulic circuit diagrams of the system:

Fig. 6-1 Hydraulic circuit layout (non-CE)

COSEN

HYDRAULIC CIRCUIT

HYDRAULIC CIRCUIT C-1000NC C-800NC

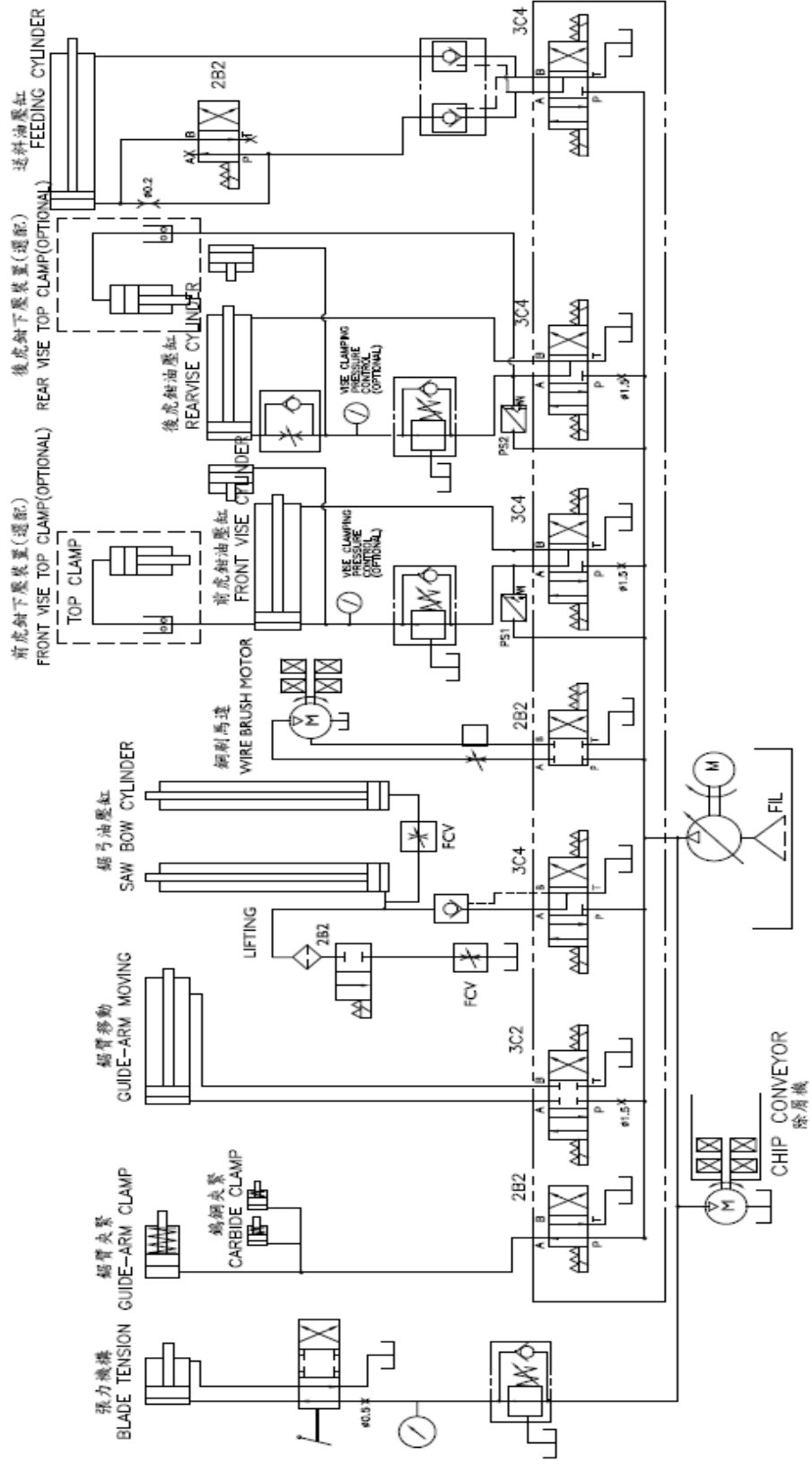

<b>COSEN</b> COSEN MACHINERY INDUSTRIAL CO.	DRAW	99/01/25	CATHERINE	NOTE :
	CHECK			
TITLE	C-1000NC C-800NC HYDRAULIC CIRCUIT		APPROVED	
DRAWING NO.	HD-C1000NC(C800NC)	VERSION	1.0	DATE
				MANE

Fig. 6-1 Hydraulic circuit layout (non-CE)

# ***BANDSAW CUTTING: A PRACTICAL GUIDE***

**INTRODUCTION  
SAW BLADE SELECTION  
VISE LOADING  
BLADE BREAK-IN**

## INTRODUCTION

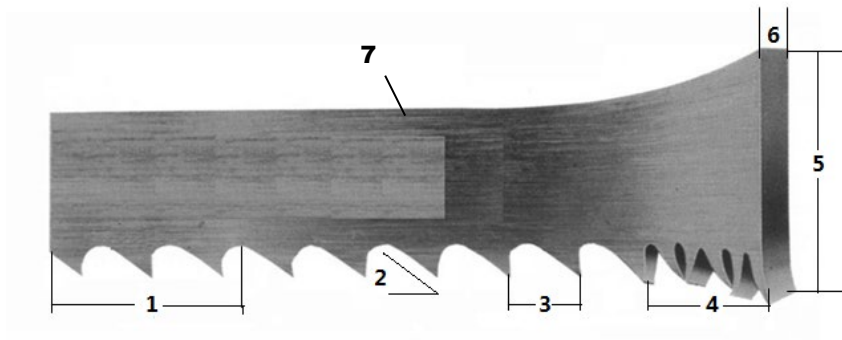

- 1. TPI:** The number of teeth per inch as measured from gullet to gullet.
- 2. Tooth Rake Angle:** The angle of the tooth face measured with respect to a line perpendicular to the cutting direction of the saw.
- 3. Tooth Pitch:** Tooth pitch refers to the number of teeth per inch (tpi). 1 inch equates to 25.4 mm.

A distinction is made between constant tooth pitches with a uniform tooth distance, 2 tpi for example, and variable tooth pitches with different tooth distances within one toothing interval.

Variable tooth pitches, for instance 2-3 tpi, can be characterized by two measures: 2 tpi stands for the maximum tooth distance and 3 tpi stands for the minimum tooth distance in the toothing interval.

### **Constant**



### **Variable**

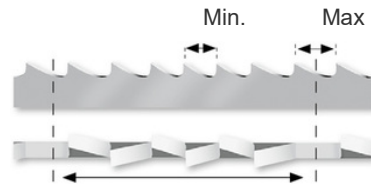

- 4. Set:** The bending of teeth to right or left to allow clearance of the back of the blade through the cut.
- 5. Width:** The nominal dimension of a saw blade as measured from the tip of the tooth to the back of the band.
- 6. Thickness:** The dimension from side to side on the blade.
- 7. Gullet:** The curved area at the base of the tooth. The tooth tip to the bottom of the gullet is the gullet depth.

## SAW BLADE SELECTION

### **1. Band length**

The dimensions of the band will depend on the band saw machine that has been installed.

Please refer to Section 2 – General Information

### **2. Band width**

Band width: the wider the band saw blade, the more stability it will have.

### **3. Cutting edge material**

The machinability of the material to be cut determines what cutting material you should choose.



#### 4. Tooth pitch

The main factor here is the contact length of the blade in the workpiece.

If it is 4P,  $25.4 \div 4 P = 6.35$  mm, that is, one tooth is 6.35 mm.

If it is 3P,  $25.4 \div 3 P = 8.46$  mm If the number is small, it means that the tooth is large.

What is written as 3/4 is that it is a variable pitch of large (3) / small (4).

The saw blade must contact the cutting material at least two pitches. In the case of a thickness of 15 mm, 4P = OK, 3P = NG.

- The surface conditions will also affect the cutting rate. If there are places on the surface on the material which are hard, a slower blade speed will be required or blade damage may result.
- It will be slower to cut tubing than to cut solids, because the blade must enter the material twice, and because coolant will not follow the blade as well.
- Tough or abrasive materials are much harder to cut than their machinability rating would indicate.
- Tooth spacing is determined by the hardness of the material and its thickness in cross section.
- Tooth set prevents the blade from binding in the cut. It may be either a "regular set" (also called a "raker set" ) or a "wavy set".
- The regular or raker set is most common and consists of a pattern of one tooth to the left, one tooth to the right, and one which is straight, or unset. This type of set is generally used where the material to be cut is uniform in size and for contour cutting.
- Wavy set has groups of teeth set alternately to right and left, forming a wave-like pattern. This reduces the stress on each individual tooth, making it suitable for cutting thin material or a variety of materials where blade changing is impractical. Wavy set is often used where tooth breakage is a problem. This is shown in Fig. 7.2 as follows:

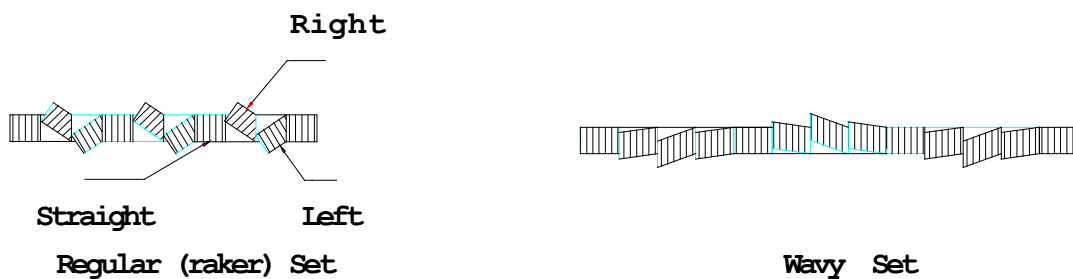

Fig. 7.2 The Saw Set

#### WISE LOADING

The position in which material is placed in the vise can have a significant impact on the cost per cut.

Often, loading smaller bundles can mean greater sawing efficiency.



When it comes to cutting odd-shaped material, such as angles, I-beams, channel, and tubing, the main point is to arrange the materials in such a way that the blade cuts through as uniform a width as possible throughout the entire distance of cut.

The following diagrams suggest some costeffective ways of loading and fixturing. Be sure, regardless of the arrangement selected, that the work can be firmly secured to avoid damage to the machine or injury to the operator.



### **BLADE BREAK-IN**

Completing a proper break-in on a new band saw blade will dramatically increase its life.

1. Select the proper band speed for the material to be cut.

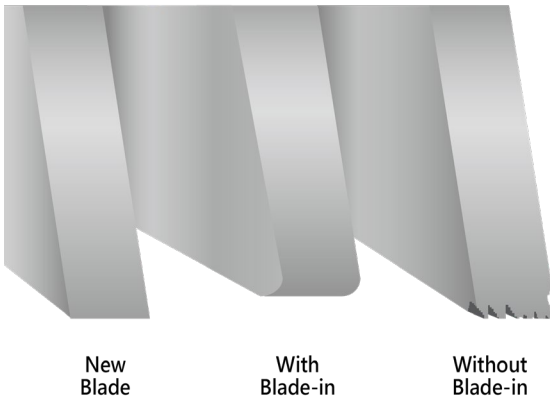

2. Reduce the feed force/rate to achieve a cutting rate 20% to 50% of normal (soft materials require a larger feed rate reduction than harder materials).

3. Begin the first cut at the reduced rate. Make sure the teeth are forming a chip. Small adjustments to the band speed may be made in the event of excessive noise/vibration. During the first cut, increase feed rate/force slightly once the blade fully enters the workpiece. With each following cut, gradually increase feed rate/force until normal cutting rate is reached.

# ***MAINTENANCE & SERVICE***

## **INTRODUCTION**

### **BASIC MAINTENANCE**

#### **MAINTENANCE SCHEDULE**

**BEFORE BEGINNING A DAY'S WORK**

**AFTER ENDING A DAY'S WORK**

**Every 2 weeks**

**First 600hrs for new machine, then every 1200hrs **for routine change****

**EVERY SIX MONTHS**

### **STORAGE CONDITIONS**

### **TERMINATING THE USE OF MACHINE**

### **OIL RECOMMENDATION FOR MAINTENANCE**

## **INTRODUCTION**

For the best performance and longer life of the band saw machine, a maintenance schedule is necessary. Some of the daily maintenance usually takes just a little time but will give remarkable results for the efficient and proper operation of cutting.

## **BASIC MAINTENANCE**

It is always easy and takes just a little effort to do the basic maintenance. But it always turns out to be a very essential process to assure the long life and efficient operation of the machine. Most of the basic maintenance requires the operator to perform it regularly.

## MAINTENANCE SCHEDULE

We suggest you do the maintenance on schedule.

### Before beginning a day's work

1. Please check the hydraulic oil level. If oil level volume is below 1/2, please add oil as necessary. (Filling up to 2/3 level is better for system operation.)
2. Please check the cutting fluid level, adding fluid as necessary. If the fluid appears contaminated or deteriorated, drain and replace it.
3. Please check the saw blade to ensure that it is properly positioned on both the drive and idle wheels.
4. Please make sure that the saw blade is properly clamped by the left and right inserts.
5. Please check the wire brush for proper contact with the saw blade. Replace the wire brush if it is worn out.

### After ending a day's work

Please remove saw chips and clean the machine with discharging the cutting fluid when work has been completed.



Do not discharge cutting fluid while the saw blade is operating because it will cause severe injury on operator's hand.



Be sure the saw blade is fully stop, it will be performed after working inspection.

### Every 2 weeks

Please apply Grease to the following points:

1. Idle wheel
2. Drive wheel
3. Blade tension device

#### Recommended Grease:

- Shell Alvania EP Grease 2
- Mobil Mobilplex 48

Please apply lubricating oil to the following points: (if applicable)  
Main shaft (double column)

#### Recommended Lubricating Oil:

- CPC Circulation oil R68

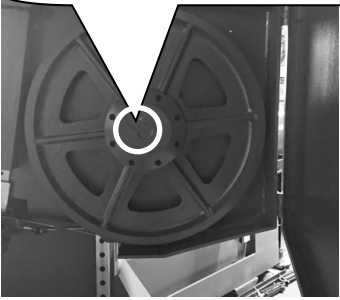
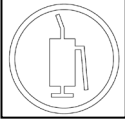
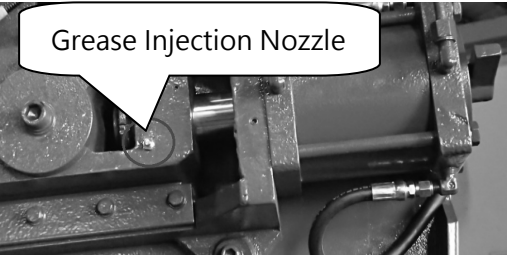
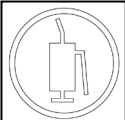

**Grease Injection Hole:**

	<ol style="list-style-type: none"> <li>Grease Injection Nozzles at the middle of drive wheel and idle wheel;  (You need to rotate the wheel until you see the Grease injection nozzle.)</li> </ol>  : The position of injection indicating. <ol style="list-style-type: none"> <li>Please inject the grease into the Nozzle.</li> </ol>
	<ol style="list-style-type: none"> <li>Grease Injection Nozzle on the blade tension device.</li> </ol>  : The position of injection indicating. <ol style="list-style-type: none"> <li>Please inject the grease into the Nozzle.</li> </ol>

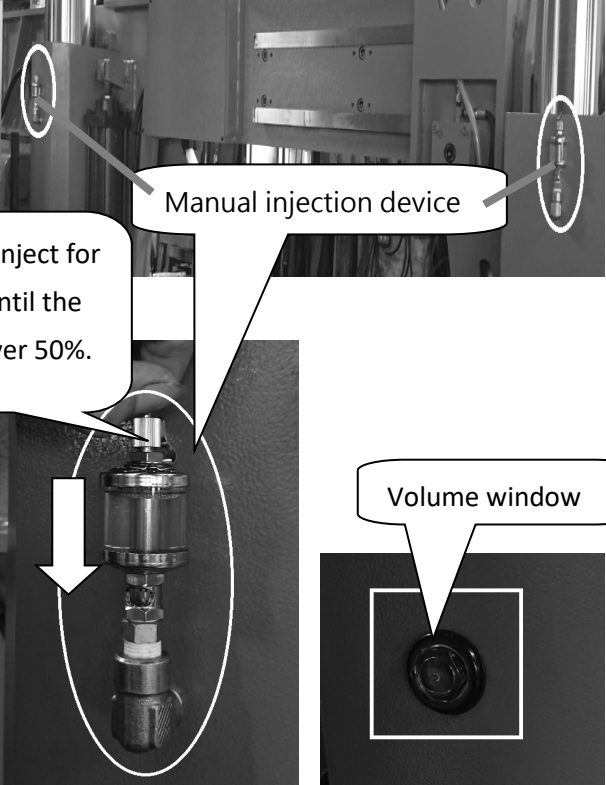
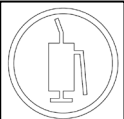
**Lubricating Oil Injection for Main shaft (double column) ( if applicable ):**

	<ol style="list-style-type: none"> <li>Two manual injection device for two main shafts (double column)</li> </ol>  : The position of injection indicating. <ol style="list-style-type: none"> <li>Pull up &amp; inject lubricating oil for seconds</li> <li>Recommend always keeping the volume over 50% inside the vessel of volume window. °</li> </ol>
---	--

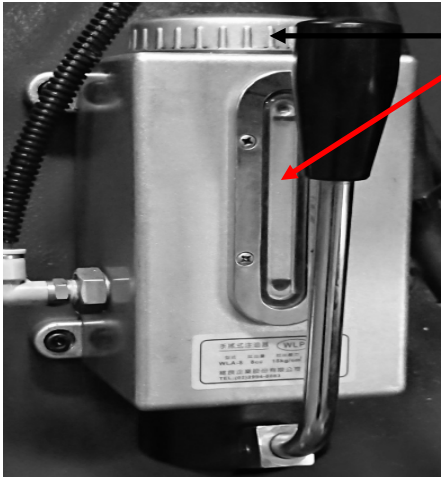
**Manual Lubrication Injection Device:** (if applicable)

	<p>Lubrication volume indicator. <b>Recommend keeping the volume over 50% inside the vessel.</b></p>
	<p> Please take down this vessel cap to replenish the lubrication.</p> <p>For the prevention of working environment pollution, <b>DO NOT</b> replenish too much volume of lubrication while supplying the lubrication into the vessel.</p> <p>Under the circumstances of normal operation, replenish the lubrication once every three days.</p> <p>It may be adjusted the schedule of replenishing whenever the user needs.</p> <p>The main function is to lubricate the <b>slide rail and block</b>. (The <b>liner guideway for saw bow</b>).</p>

First 600hrs for new machine, then every 1200hrs **for routine change**

Replace the transmission oil after operating for first 600hrs for new machine, then every 1200hrs

Recommended gear oil

- Shell Omala oil HD220
- Mobil gear 630

Recommended hydraulic oil

- ShellTellus 32
- Mobil DTE Oil Light Hydraulic 24

Every six months

1. Clean the filter of the cutting fluid.
2. Replace the transmission oil for every half of a year (or 1200 hours).  
Check the sight gauge to ascertain the transmission level.

Recommended TRANSMISSION OIL

- Omala oil HD220
- Mobil comp 632 600W Cylinder oil

3. Replace the hydraulic oil.

Recommended HYDRAULIC OIL

- ShellTellus 32
- Mobil DTE Oil Light Hydraulic 24

### Gear Oil & Grease Injection Hole:

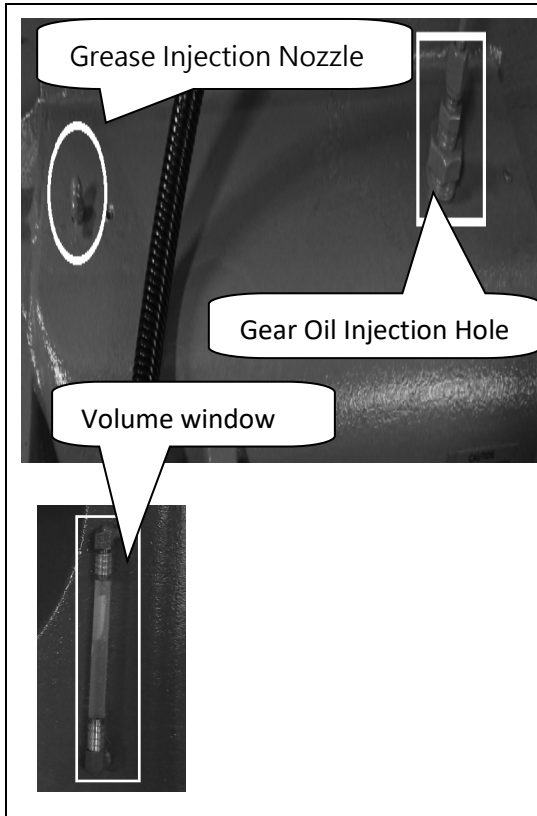

1. A grease injection hole and a gear oil injection hole on the top of gear reducer.

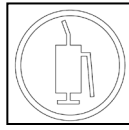

: The position of injection indicating.

2. Recommend keeping the volume under 50% inside the vessel of volume window. °

**\*NOTE: Over 50% oil in the gear box will cause oil spilling out.**

3. To use the machine in a sub-zero environment, please add antifreeze into gear reducer.

### To unload the waste fluid:

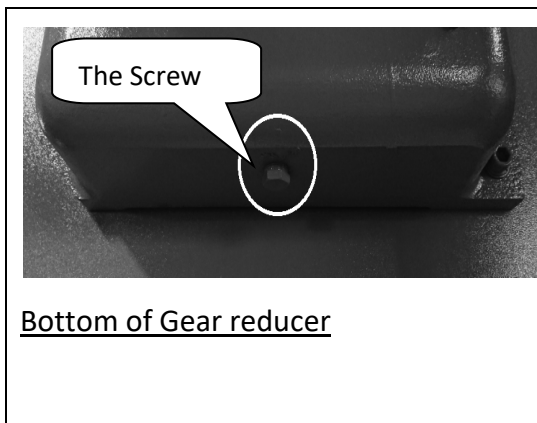

1. Put the waste oil container in the bottom of the reducer for unloading waste fluid .
2. Use the wrench to open the screw for unloading the waste fluid.
3. Make sure the screw bolted tightly after unloading completed,

### **STORAGE CONDITIONS**

Generally, this machine will be stored on the following conditions in future:

- (1) Turn off the power.
- (2) Ambient temperature: 5°C ~ 40°C
- (3) Relative humidity: 30%~85% (without condensation)
- (4) Atmosphere: use a plastic canvas to cover machine to avoid excessive dust, acid fume, corrosive gases and salt.
- (5) Avoid exposing to direct sunlight or heat rays which can change the environmental temperature.
- (6) Avoid exposing to abnormal vibration.
- (7) Must be connected to earth.

## TERMINATING THE USE OF THE MACHINE

Waste disposal:

When your machine can not work anymore, you should **drain** the oil from machine body. Please **store** the oil in safe place with bottom **tray**. Ask a environment specialist to handle the oil. It can avoid soil pollution. The oil list in machine:

- Hydraulic oil
- Cutting fluid
- Drive wheel gear oil

## OIL RECOMMENDATION FOR MAINTENANCE

Item	Method	Revolution	Suggest oil
Dovetail guide	Keep grease covered. Antirust.	Daily	Shell R2
Roller bearing	Sweep clean and oil with lubricant.	Daily	SAE #10
Bed roller / surface	Sweep clean and oil with lubricant.	Daily	SAE #10
Nipples of bearing	Use grease gun, but not excess.	Monthly	Shell R2
Blade tension device	Use grease gun, but not excess.	Monthly	Shell Alvania EP Grease 2, Mobil Mobilplex 48
Reducer	Inspect once a week. Change oil of 600 hours of using. Change it every year.	Regularly	Omala oil HD220 Mobil Gear 630
Hydraulic system	Inspect half a year. Change oil every year.	Regularly	Shell Tellus 32 Mobil DTE oil Light Hydraulic 24
Bearing	Inserts	Oil with lubricant, but not excess.	Daily
	Band wheel	Oil with lubricant, but not excess.	Weekly
	Cylinder	Oil with lubricant, but not excess.	6 Monthly
	Wire brush	Oil with lubricant, but not excess.	6 Monthly



- 1. Turn off the stop circuit breaker switch before servicing the machine.**
- 2. Then post a sign to inform people that the machine is under maintenance.**
- 3. Drain all of the cutting fluid and oil off and carefully treat them to avoid pollution.**
- 4. The machine must be either LOCKED OUT OR TAGGED OUT while under maintenance.**



# **TROUBLESHOOTING**

## **INTRODUCTION**

## **PRECAUTIONS**

## **GENERAL TROUBLES & SOLUTIONS**

## **MINOR TROUBLES & SOLUTIONS**

## **MOTOR TROUBLES & SOLUTIONS**

## **BLADE TROUBLES & SOLUTIONS**

## **SAWING PROBLEMS & SOLUTIONS**

## **RE-ADJUSTING THE ROLLER TABLE**

## **INTRODUCTION**

All the machines manufactured by us pass a 72 hours continuously running test before shipping out and we are responsible for the after sales service problems during the warranty period if the machines are used normally. However, there still exist the some unpredictable problems which may disable the machine from operating.

Generally speaking, the system troubles in this machine model can be classified into three types, namely GENERAL TROUBLES, MOTOR TROUBLES and BLADE TROUBLES. Although you may have other troubles which can not be recognized in advance, such as malfunctions due to the limited life-span of mechanical, electric or hydraulic parts of the machine.

We have accumulated enough experiences and technical data to handle all of the regular system troubles. Meanwhile, our engineering department had been continuously improving the machines to prevent all possible troubles.

It is hoped that you will give us your maintenance experience and ideas so that both sides can achieve the best performance.

## PRECAUTIONS

When an abnormality occurs in the machine during operation, you can do it yourself safely. If you have to stop machine motion immediately for parts exchanging, you should do so according to the following procedures:

- Press HYDRAULIC MOTOR OFF button or EMERGENCY STOP button.
- Open the electrical enclosure door.
- Turn off breaker.



**BEFORE ANY ADJUSTMENT OR MAINTENANCE OF THE MACHINE, PLEASE MAKE SURE TO TURN OFF THE MACHINE AND DISCONNECT THE POWER SUPPLY.**

## GENERAL TROUBLES AND SOLUTIONS



**DISCONNECT POWER CORD TO MOTOR BEFORE ATTEMPTING ANY REPAIR OR INSPECTION.**

TROUBLE	PROBABLE CAUSE	SUGGESTED REMEDY
Motor stalls	Excessive belt tension	Adjust belt tension so that belt does not slip on drive pulley while cutting ( 1/2" Min. deflection of belt under moderate pressure.)
	Excessive head pressure	Reduce head pressure. Refer to Operating Instructions "Adjusting Feed".
	Excessive blade speed	Refer to Operating Instructions "Speed Selection".
	Improper blade selection	Refer to Operating Instructions "Blade Selection".
Cannot make square cut	Dull blade	Replace blade.
	Guide rollers not adjusted properly	Refer to Adjustments.
	Rear vise jaw not adjusted properly	Set fixed vise jaw 90° to blade.
	Excessive head pressure	Reduce head pressure. Refer to operating instructions "Adjusting Feed."
Increased cutting time	Dull blade	Replace blade
	Insufficient head pressure	Increase head pressure. Refer to Operating Instructions "Adjusting Feed."
	Reduce blade speed	Refer to Operating Instructions "Speed Selection."
Will not cut	Motor running in wrong direction	Reverse rotation of motor. (Motor rotation C.C.W. pulley end.)
	Blade teeth pointing in wrong direction	Remove blade, turn blade inside out. Re-install blade. (Teeth must point in direction of travel. )
	Hardened material	Use special alloy blades. (Consult your industrial distributor for recommendation on type of blade required.)

## MINOR TROUBLES & SOLUTIONS

TROUBLE	PROBABLE CAUSE	SUGGESTED REMEDY
Saw blade motor does not run even though blade drive button is pressed.	Overload relay activated	Reset
	Saw blade is not at forward limit position.	Press SAW FRAME FORWARD button

## MOTOR TROUBLES & SOLUTIONS

TROUBLE	PROBABLE CAUSE	SUGGESTED REMEDY
Motor will not start	Magnetic switch open, or protector open.	Reset protector by pushing red button (inside electric box.)
	Low voltage	Check power line for proper voltage.
	Open circuit in motor or loose connections.	Inspect all lead terminations on motor for loose or open connections.
Motor will not start, fuse or circuit breakers "blow".	Short circuit in line, cord or plug.	Inspect line, cord and plug for damaged insulation and shorted wire.
	Short circuit in motor or loose connections	Inspect all lead terminations on motor for loose or shorted terminals or worn insulation on wires.
	Incorrect fuses or circuit breakers in power line.	Install correct fuses or circuit breakers.
Motor fail to develop full power. (Power output of motor decreases rapidly with decrease in voltage at motor terminals.)	Power line overloaded with lights, appliances and other motors.	Reduce the load on the power line.
	Undersize wires or circuit too long.	Increase wire sizes, or reduce length of wiring
	General overloading of power company's facilities.	Request a voltage check from the power company
Motor overheat	Motor overloaded.	Reduce load on motor
	Air circulation through the motor restricted.	Clean out motor to provide normal air circulation through motor.
Motor stalls (Resulting in blown fuses or tripped circuit breakers)	Short circuit in motor or loose connections.	Inspect terminals in motor for loose or shorted terminals or worn insulation on lead wires.
	Low voltage	Correct the low line voltage conditions.
	Incorrect fuses or circuit breakers in power line.	Install correct fuses circuit breakers.
	Motor overloaded	Reduce motor load.
Frequent opening of fuses or circuit breakers.	Motor overloaded	Reduce motor load
	Incorrect fuses or circuit breakers.	Install correct fuses or circuit breakers.

## BLADE TROUBLES AND SOLUTIONS



**DISCONNECT POWER CORD TO MOTOR BEFORE ATTEMPTING ANY REPAIR OR INSPECTION.**

TROUBLE	PROBABLE CAUSE	SUGGESTED REMEDY
Teeth strippage	Too few teeth per inch	Use finer tooth blade
	Loading of gullets	Use coarse tooth blade or cutting lubricant.
	Excessive feed	Decrease feed
	Work not secured in vise	Clamp material securely
Blade breakage	Teeth too coarse	Use a finer tooth blade
	Misalignment of guides	Adjust saw guides
	Dry cutting	Use cutting lubricant
	Excessive speed	Lower speed. See Operating Instructions "Speed selection."
	Excessive speed	Reduce feed pressure. Refer to Operating Instructions "Adjusting Feed."
	Excessive tension	Tension blade to prevent slippage on drive wheel while cutting.
Blade line Run-out or Run-in	Wheels out of line	Adjust wheels
	Guides out of line	For a straight and true cut, realign guides, check bearings for wear.
	Excessive pressure	Conservative pressure assures long blade life and clean straight cuts.
	Support of blade insufficient	Move saw guides as close to work as possible.
	Material not properly secured in vise	Clamp material in vise, level and securely.
Blade twisting	Blade tension improper	Loosen or tighten tension on blade.
	Blade not in line with guide bearings	Check bearings for wear and alignment.
	Excessive blade pressure	Decrease pressure and blade tension
Premature tooth wear	Blade binding in cut	Decrease feed pressure
	Dry cutting	Use lubricant on all materials, except cast iron
	Blade too coarse	Use finer tooth blade
	Not enough feed	Increase feed so that blade does not ride in cut
	Excessive speed	Decrease speed

## SAWING PROBLEMS AND SOLUTIONS

Other than this manual, the manufacturer also provides some related technical documents listed as follows:

### Sawing Problems and Solutions

					Vibration during cutting	Failure to cut	Short life of saw blade	Curved cutting	Broken blade		
✓	✓	✓	✓	✓						Use of blade with incorrect pitch	Use blade with correct pitch suited to workpiece width
✓	✓	✓	✓	✓						Failure to break-in saw blade	Perform break-in operation
✓	✓	✓								Excessive saw blade speed	Reduce speed
			✓	✓						Insufficient saw blade speed	Increase speed
✓		✓	✓	✓						Excessive saw head descending speed	Reduce speed
✓		✓	✓							Insufficient saw head descending speed	Increase speed
		✓	✓							Insufficient saw blade tension	Increase tension
✓		✓	✓	✓						Wire brush improperly positioned	Relocate
✓		✓	✓							Blade improperly clamped by insert	Check and correct
✓	✓	✓	✓	✓						Improperly clamped workpiece	Check and correct
	✓	✓	✓							Excessively hard material surface	Soften material surface
		✓	✓	✓						Excessive cutting rate	Reduce cutting rate
	✓	✓								Non-annealed workpiece	Replace with suitable workpiece
✓		✓	✓	✓						Insufficient or lean cutting fluid	Add fluid or replace
✓		✓	✓	✓						Vibration near machine	Relocate machine
		✓	✓							Non-water soluble cutting fluid used	Replace
✓		✓	✓							Air in cylinder	Bleed air
✓		✓		✓						Broken back-up roller	Replace
✓	✓	✓	✓	✓						Use of non-specified saw blade	Replace
✓	✓	✓	✓	✓						Fluctuation of line voltage	Stabilize
✓		✓	✓							Adjustable blade guide too far from workpiece	Bring blade guide close to workpiece
✓		✓	✓	✓						Loose blade guide	Tighten
		✓		✓						Blue or purple saw chips	Reduce cutting rate
✓		✓		✓						Accumulation of chips at inserts	Clean
	✓									Reverse positioning of blade on machine	Reinstall
✓		✓	✓							Workpieces are not bundled properly	Re-bundle
✓		✓		✓						Back edge of blade touching wheel flange	Adjust wheel to obtain clearance
✓	✓	✓								Workpiece of insufficient diameter	Use other machine, suited for diameter of workpiece
	✓	✓	✓							Saw blade teeth worn	Replace

## **SOLUTIONS TO SAWING PROBLEMS**

### Table Of Contents

#1. Heavy Even Wear On Tips and Corners Of Teeth	#11. Uneven Wear Or Scoring On The Sides Of Band
#2. Wear On Both Sides Of Teeth	#12. Heavy Wear And/Or Swagging On Back Edge
#3. Wear On One Side Of Teeth	#13. Butt Weld Breakage
#4. Chipped Or Broken Teeth	#14. Heavy Wear In Only The Smallest Gullets
#5. Body Breakage Or Cracks From Back Edge	#15. Body Breaking – Fracture Traveling In An Angular Direction
#6. Tooth Strippage	#16. Body Breakage Or Cracks From Gullets
#7. Chips Welded To Tooth Tips	#17. Band is Twisted Into A Figure "8" Configuration
#8. Gullets Loading Up With Material	#18. Used Band Is "Long" On The Tooth Edge
#9. Discolored Tips Of Teeth Due To Excessive Frictional Heat	#19. Used Band Is "Short" On The Tooth Edge
#10. Heavy Wear On Both Sides Of Band	#20. Broken Band Shows A Twist In Band Length.

### **#1. Heavy Even Wear On Tips and Corners Of Teeth**



#### **Probable Cause :**

- A.** Improper break-in procedure.
- B.** Excessive band speed for the type of material being cut. This generates a high tooth tip temperature resulting in accelerated tooth wear.
- C.** Low feed rate causes teeth to rub instead of penetrate. This is most common on work hardened materials such as stainless and toolsteels.
- D.** Hard materials being cut such as "Flame Cut Edge" or abrasive materials such as " Fiber Reinforced Composites".
- E.** Insufficient sawing fluid due to inadequate supply, improper ratio, and/or improper application

## #2. Wear On Both Sides Of Teeth

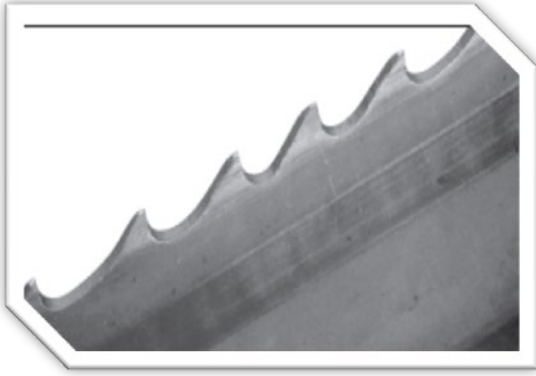

### Probable Cause :

- A. Broken, worn or missing back-up guides allowing teeth to contact side guides.
- B. Improper side guides for band width.
- C. Backing the band out of an incomplete cut.

## #3. Wear On One Side Of Teeth

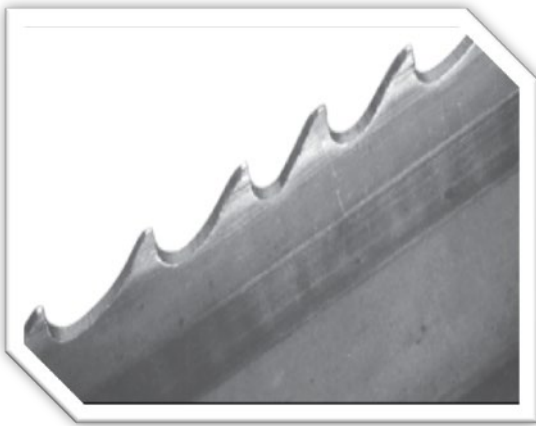

### Probable Cause :

- A. Worn wheel flange, allowing side of teeth to contact wheel surface or improper tracking on flangeless wheel.
- B. Loose or improperly positioned side guides.
- C. Blade not perpendicular to cut.
- D. Blade rubbing against cut surface on return stroke of machine head.
- E. The teeth rubbing against a part of machine such as chip brush assembly, guards, etc.

## #4. Chipped Or Broken Teeth



### Probable Cause :

- A. Improper break-in procedure.
- B. Improper blade selection for application.
- C. Handling damage due to improper opening of folded band.
- D. Improper positioning or clamping of material.
- E. Excessive feeding rate or feed pressure.
- F. Hitting hard spots or hard scale in material

### #5. Body Breakage Or Cracks From Back Edge

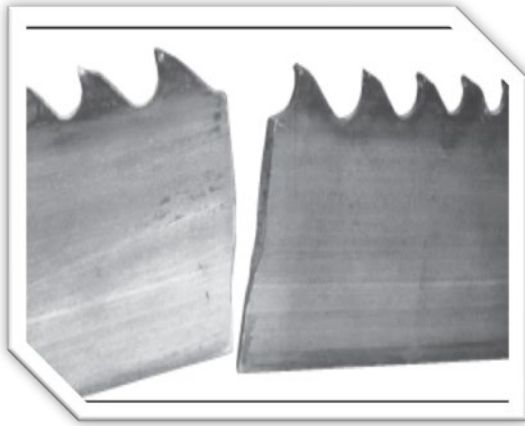

#### Probable Cause :

- A. Excessive back-up guide "preload" will cause back edge to work harden which results in cracking.
- B. Excessive feed rate.
- C. Improper band tracking – back edge rubbing heavy on wheel flange.
- D. Worn or defective back-up guides.
- E. Improper band tension.
- F. Notches in back edge from handling damage

### #6. Tooth Strippage



#### Probable Cause :

- A. Improper or lack of break-in procedure.
- B. Worn, missing or improperly positioned chip brush.
- C. Excessive feeding rate or feed pressure.
- D. Movement or vibration of material being cut.
- E. Improper tooth pitch for cross sectional size of material being cut.
- F. Improper positioning of material being cut.
- G. Insufficient sawing fluid due to inadequate supply, improper ratio and/or improper application.
- H. Hard spots in material being cut.
- I. Band speed too slow for grade of material being cut.

### #7. Chips Welded To Tooth Tips

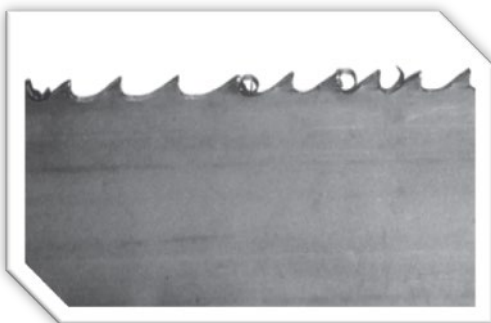

#### Probable Cause :

- A. Insufficient sawing fluid due to inadequate supply, improper ratio and/or improper application.
- B. Worn, missing or improperly positioned chip brush.
- C. Improper band speed.
- D. Improper feeding rate.



## #8. Gullets Loading Up With Material

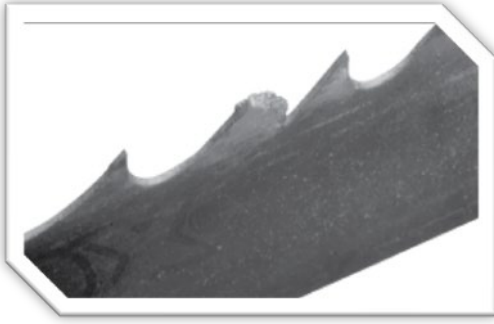

### Probable Cause :

- A. Too fine of a tooth pitch – insufficient gullet capacity.
- B. Excessive feeding rate producing too large of a chip.
- C. Worn, missing or improperly positioned chip brush.
- D. Insufficient sawing fluid due to inadequate supply, improper ratio and/or improper application.

## #9. Discolored Tips Of Teeth Due To Excessive Frictional Heat

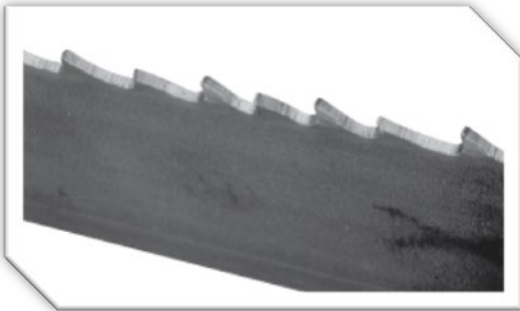

### Probable Cause :

- A. Insufficient sawing fluid due to inadequate supply, improper ratio and/or improper application.
- B. Excessive band speed.
- C. Improper feeding rate.
- D. Band installed backwards.

## 10. Heavy Wear On Both Sides Of Band

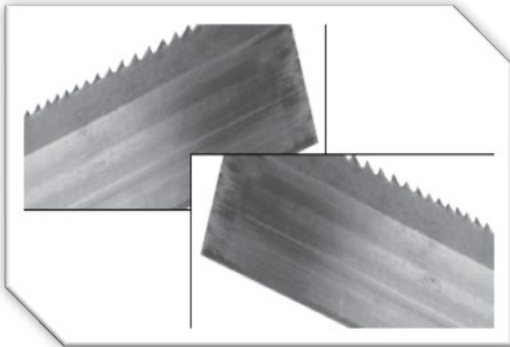

### Probable Cause :

- A. Chipped or broken side guides.
- B. Side guide adjustment may be too tight.
- C. Insufficient flow of sawing fluid through the side guides.
- D. Insufficient sawing fluid due to inadequate supply, improper ratio and/or improper application.

## #11. Uneven Wear Or Scoring On The Sides Of Band

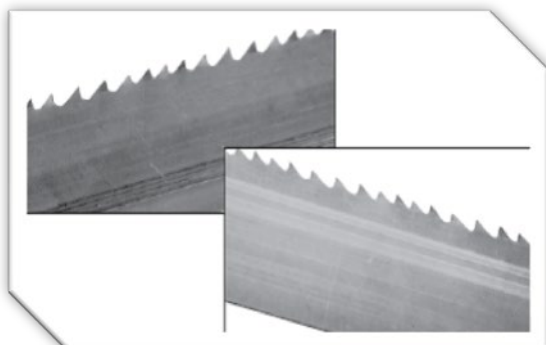

### Probable Cause :

- A. Loose side guides.
- B. Chipped, worn or defective side guides.
- C. Band is rubbing on part of the machine.
- D. Guide arms spread to maximum capacity.
- E. Accumulation of chips in side guides.

### #12. Heavy Wear And/Or Swagging On Back Edge



**Probable Cause :**

- A. Excessive feed rate.
- B. Excessive back-up guide "preload".
- C. Improper band tracking – back edge rubbing heavy on wheel flange.
- D. Worn or defective back-up guides.

### #13. Butt Weld Breakage



**Probable Cause :**

- A. Any of the factors that cause body breaks can also cause butt weld breaks.
- (See Observations #5, #15 and #16)**

### #14. Heavy Wear In Only The Smallest Gullets



**Probable Cause :**

- A. Excessive feeding rate.
- B. Too slow of band speed.
- C. Using too fine of a tooth pitch for the size of material being cut.

### #15. Body Breaking – Fracture Traveling In An Angular Direction

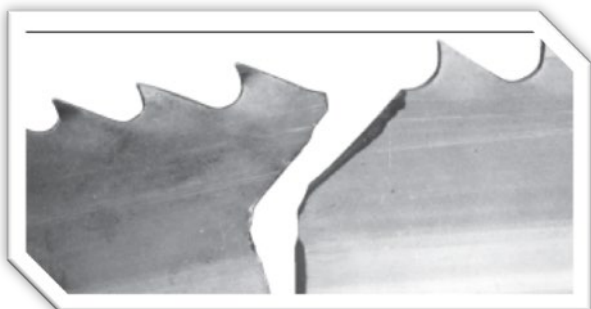

**Probable Cause :**

- A. An excessive twist type of stress existed.
- B. Guide arms spread to capacity causing excessive twist from band wheel to guides.
- C. Guide arms spread too wide while cutting small cross sections.
- D. Excessive back-up guide "preload".

## #16. Body Breakage Or Cracks From Gullets

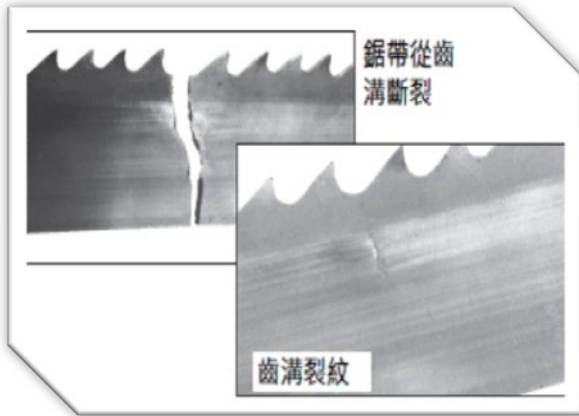

### Probable Cause :

- A. Excessive back-up guide "preload".
- B. Improper band tension.
- C. Guide arms spread to maximum capacity.
- D. Improper beam bar alignment.
- E. Side guide adjustment is too tight.
- F. Excessively worn teeth.

## #17. Band is Twisted Into A Figure "8" Configuration

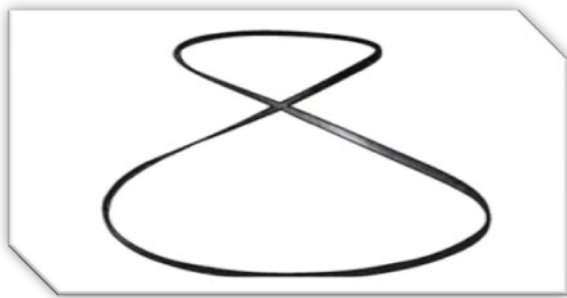

### Probable Cause :

- A. Excessive band tension.
- B. Any of the band conditions which cause the band to be long (#18) or short (#19) on tooth edge.
- C. Cutting a tight radius.

## #18. Used Band Is "Long" On The Tooth Edge



### Probable Cause :

- A. Side guides are too tight – rubbing near gullets.
- B. Excessive "preload" – band riding heavily against back-up guides.
- C. Worn band wheels causing uneven tension.
- D. Excessive feeding rate.
- E. Guide arms are spread to maximum capacity.
- F. Improper band tracking – back edge rubbing heavy on wheel flange.

## #19. Used Band Is "Short" On The Tooth Edge



### Probable Cause :

- A. Side guides are too tight – rubbing near back edge.
- B. Worn band wheels causing uneven tension.
- C. Guide arms are spread too far apart.
- D. Excessive feeding rate.

## #20. Broken Band Shows A Twist In Band Length



### Probable Cause :

- A. Excessive band tension
- B. Any of the band conditions which cause the band to be long (#18) or short (#19) on tooth edge.
- C. Cutting a tight radius.

## RE-ADJUSTING THE ROLLER TABLE

If the feeding table suffers the huge stroke and the alignment is effected, follow the below procedure to adjust.

### TOOL, measuring

Measurement, Horizontal balance

### Procedure

1. Screw or loosen the adjusting bolt to attain the horizontal balance (leveling) between the roller table and the machine frame.
2. Ensure that the machine frame is not struck by the loaded material on the feeding table.
3. Check the leveling by the measuring tool.
4. After finished the adjusting, fix the roller table.



**If the feeding table and the machine frame are not positioned under the horizontal balance, the loaded material may be going up gradually and affect the cutting effect.**

# PARTS

## SPARE PARTS RECOMMENDATIONS

### PART LIST

## SPARE PARTS RECOMMENDATIONS

The following table lists the common spare parts we suggest you purchase in advance:

<b>Part Name</b>	<b>Part Name</b>
Saw blade	Coolant tank filter
Wire brush	Steel plates
Carbide inserts	Rollers
Bearings	Coolant pump
Hydraulic tank leak-proof gasket	Belt
Rubber washer	Duster seal
Gear reducer	Oil seal
O-ring	Snap ring
Drive wheel	Idle wheel

C-800NC

NO.	PART NO.	PART NAME	QTY
1	Base Assembly	Base Assembly	1
3	Saw bow assembly	Saw bow assembly	1
5	Bed Assembly	Bed Assembly	1
7	Control box assembly	Control box assembly	1
9	CGI-C001	Chip conveyor assembly	1

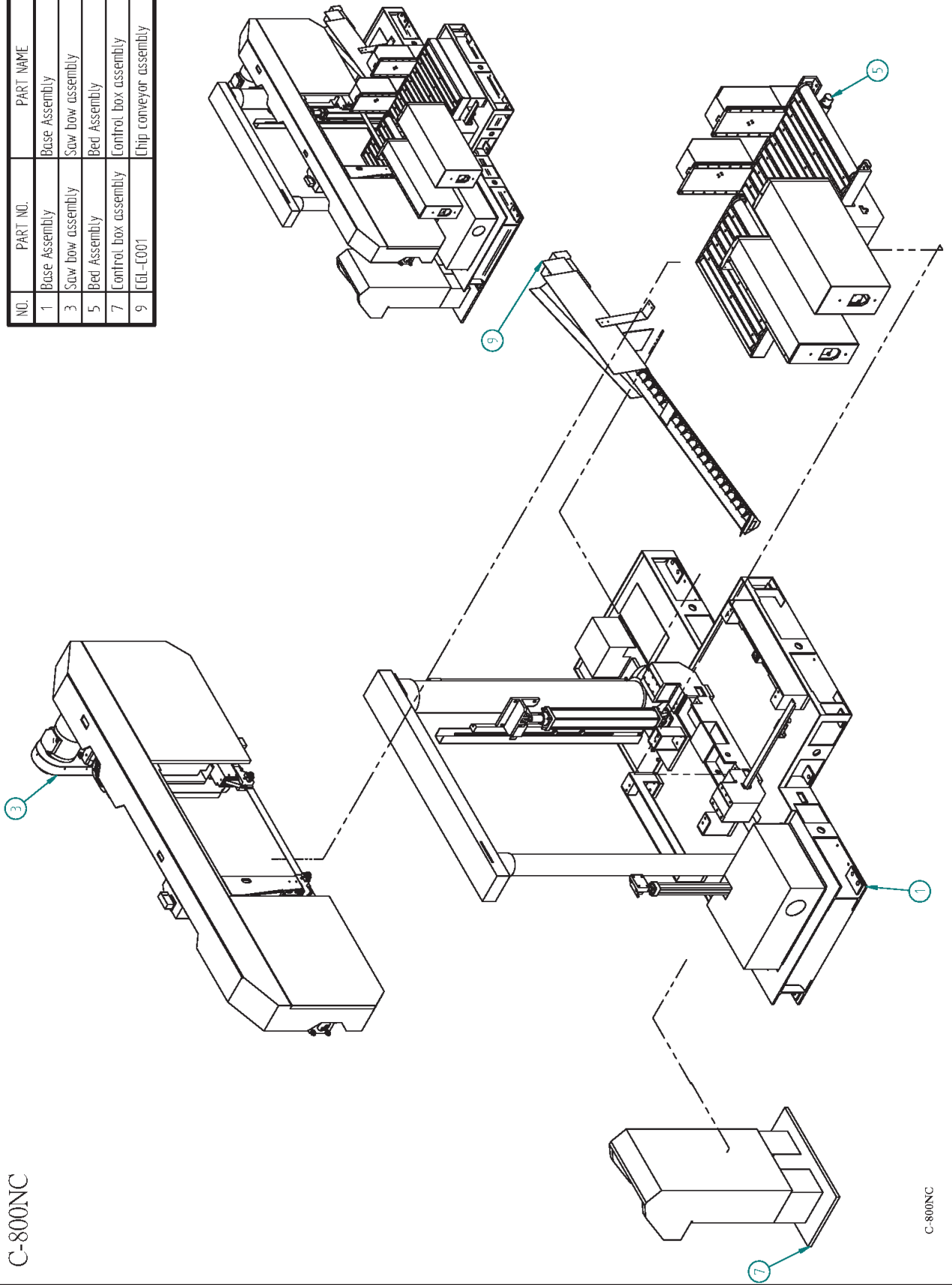

C-800NC

NO.	PART NO.	PART NAME	QTY
1	CGL-1001A	Base	1
3	CGL-1010A	Main shaft	1
5	SGL-1012A	Sub shaft	1
7	CGL-1007	Workbed stand A (front)	1
9	CGL-1009	Workbed stand C (rear)	1
11	CGL-1030	Manifold cover	1
13	CGL-1038A	Pump cover	1
15	CGL-1012	Front vise base	1
17	AGE-1008A	Workbed stand B (front)	1
19	AGE-1008B	Workbed stand B (front)	1
21	CGL-1053	Coolant tank cover	1
23	CGL-1032	Oil tank cover	1
25	PP-43423C	Cylinder	1
27	SGL-3011BY1	Sawbow cylinder ear	1
29	AGB-70303B	Sawbow cylinder ear	1
31	AGB-70304A	Pin	1
33	AGE-11080-1	Sawbow cylinder assembly	1
35	SDM-2038	Sawbow cylinder seat	1
37	SDM-2046	Sawbow cylinder pivot shaft	1
39	SDM-2046A	Sawbow cylinder pin	1
41	PP-14480	Connecting rod bearing pos.18	1
43	PP-14482	Connecting rod bearing pos.25	1
45	PP-14297A	Bearing 6304ZZ	1
47	AGE-1029	Wire protection sleeve	1
49	SGL-1020Y2	Gross beam holder #1	1
51	SGL-1021AY1	Gross beam holder #2	1
53	SGL-1022AY1	Gross beam	1
55	Feed length decoder	Feed length decoder	1
57	AGE-1025	Rear feed cylinder cover	1
59	CGL-21000	Sawbow height decoder	1

Base Assembly

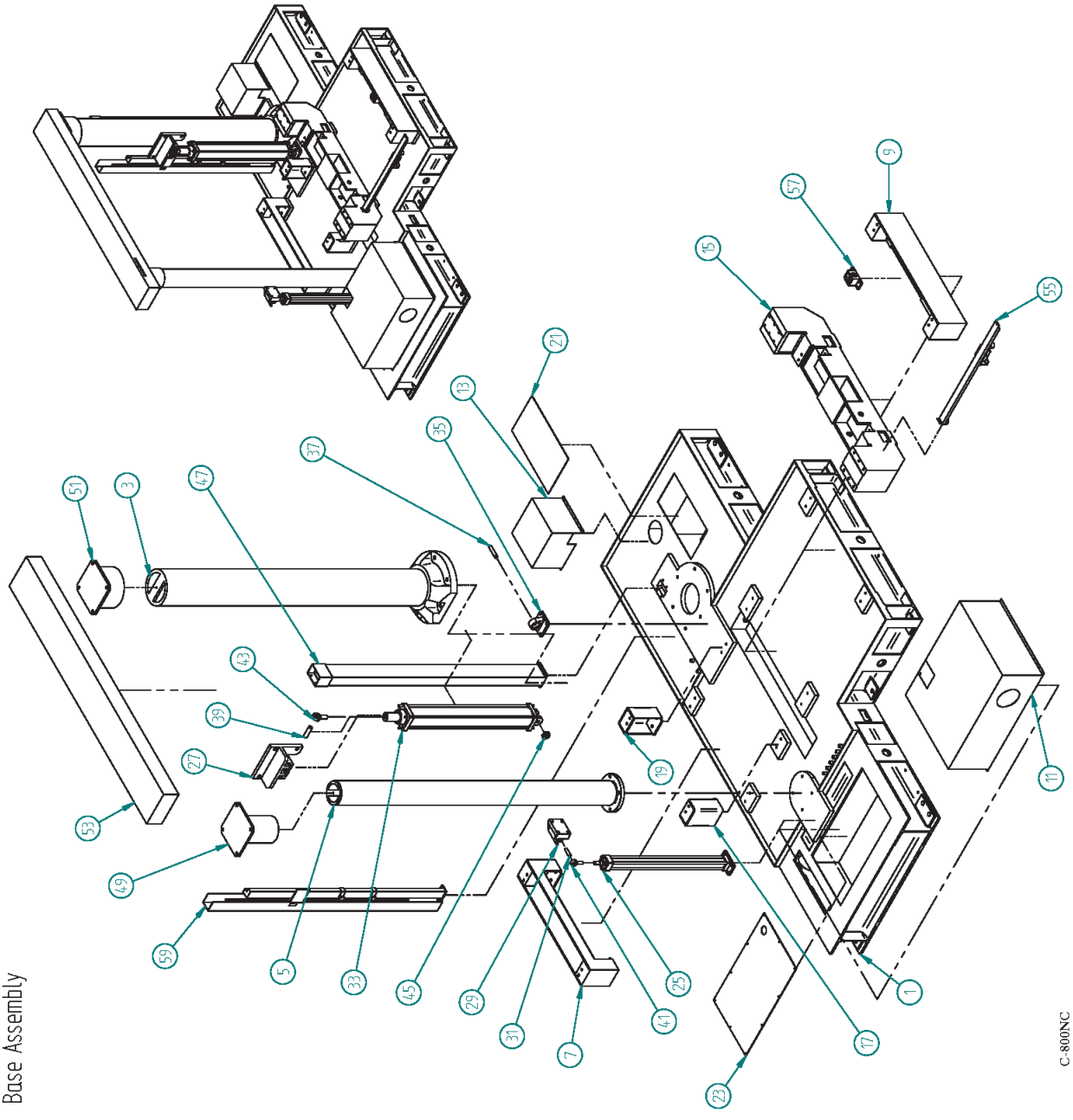

C-800NC

# CGL-21000

NO.	PART NO.	PART NAME	QTY
1	SPM-2113	Tooth bar seat #2	1
3	SPM-2111	Tooth bar seat #1	1
5	SGT-3057	Tooth bar cover	1
7	SGO-1039	Limit switch seat	1
9	SGN-1047B	Height control bar	1
11	SGJ-1072C	Height slide block	1
13	SGJ-1072B	Height slide block	1
15	S1010-1147	Lock block	2
17	PP-53021	Screw	2
19	PP-13020	DU bushing	2
21	AHA-1565	Spring	1
23	AHA-1561-3	Tooth bar	1
25	AHA-1560	Inch wheel	1
27	AGB-70536	Decoder holder #2	1
29	AGB-70535	Decoder holder #1	1

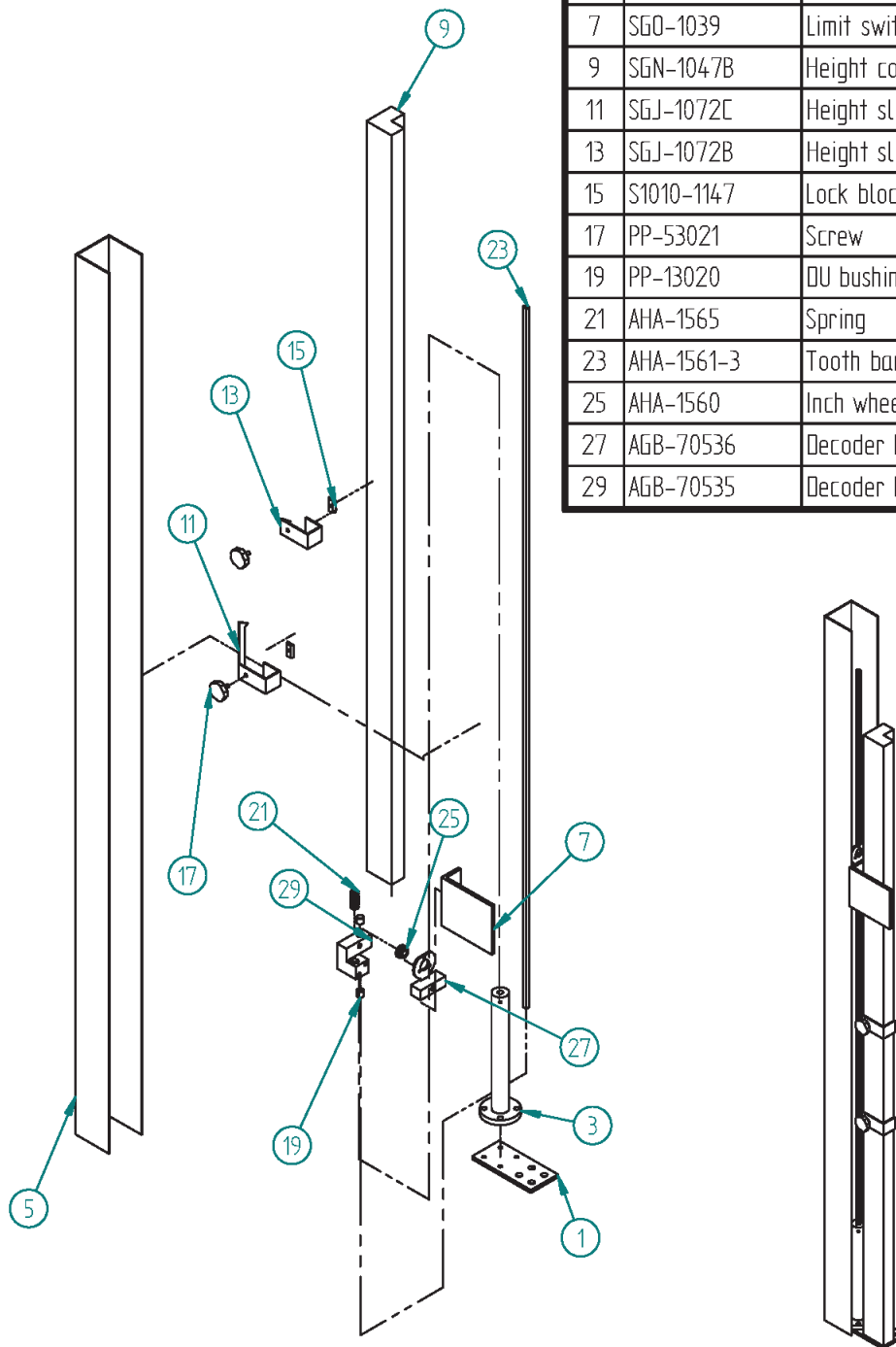

C-800NC



# Feed length decoder

NO.	PART NO.	PART NAME	QYT
1	AHA-1563	Encoder seat	1
3	AHA-1564	Tooth bar seat	1
5	AHA-1565	Spring	1
7	AHA-1561-2	Tooth bar	1
9	AHA-1562	Movable plate	1
11	AHA-1560	Gear	1
13	PP-90492	Encoder	1
15	PP-90492-1	Gear coupling	1
17	AGB-70539	Encoder bottom plate	1
19	L800H-2119	Tooth bar cover	1

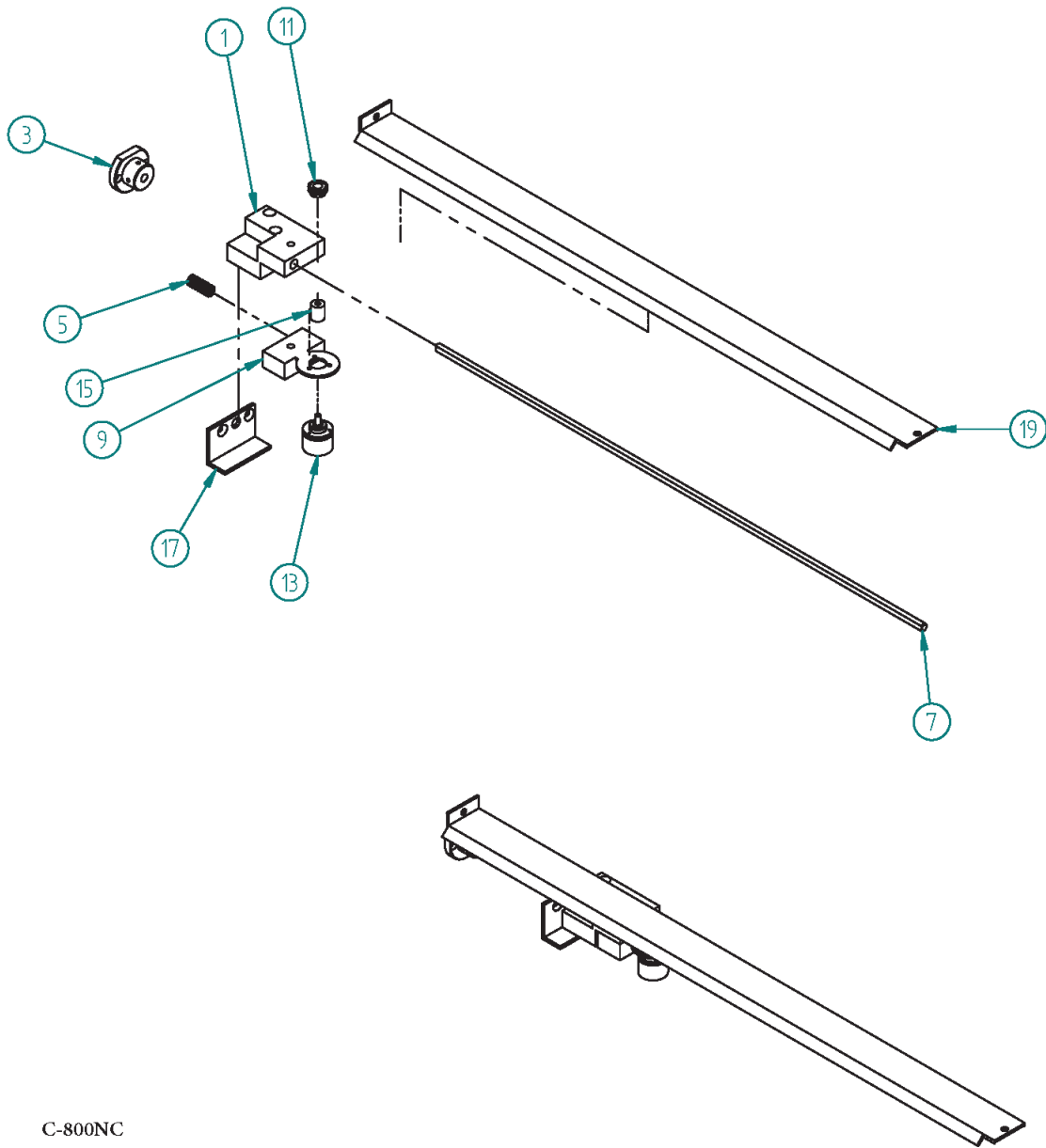

C-800NC

Saw bow assembly

NO.	PART NO.	PART NAME	QTY
1	AGL-3001B	Saw bow	1
3	SGJ-21010	Tension sliding assembly	1
5	SGJ-32800-1	Guide arm	1
7	SGJ-21030	Blade tension cylinder assembly	1
9	S8550-3127	Guide arm cylinder ear	1
11	CGL-3035A	Main shaft sleeve	1
13	AGL-3010	Sub shaft sleeve	1
15	SEL-30550	Guide roller assembly (left)	1
17	SEL-30560	Guide roller assembly (right)	1
19	CGL-1037	Sleeve cap B	1
21	CGL-1036	Sleeve cap A	1
23	PP-13359	DU bushing	2
25	PP-51135A	Oil seal	2
27	PP-51129	Oil seal	2
29	PP-13360	DU bushing	2
31	AGE-2083	90° elbow hose connector	1
33	CGL-3004	Tension controller cover	1
35	Idle wheel assembly	Idle wheel assembly	1
37	Blade motor assembly	Blade motor assembly	1
39	AGL-3003A	Drive wheel	1
41	SEN-3070	Guide arm sliding plate	1
43	SEL-3005C	Fixed guide arm C	1
45	AGL-3005	Movable guide arm	1
47	S8550-3108	Guide arm fixed back #2	1
49	PP-18803	Blade	1
51	CGL-3013	Guide arm cylinder fixed plate	1
53	S8550-3118	Guide arm cover (left)	1
55	SEL-3006	Guide arm fixed block	1
57	SEL-3071	Guide arm cover (right)	1
59	PP-43397	Hydraulic cylinder	1
61	AGL-3006A	Idle wheel cover	1
63	AGL-3007A	Driving wheel cover	1
65	Wire brush assembly	Wire brush assembly	1
67	SEL-3047A	Saw frame housing cover	1

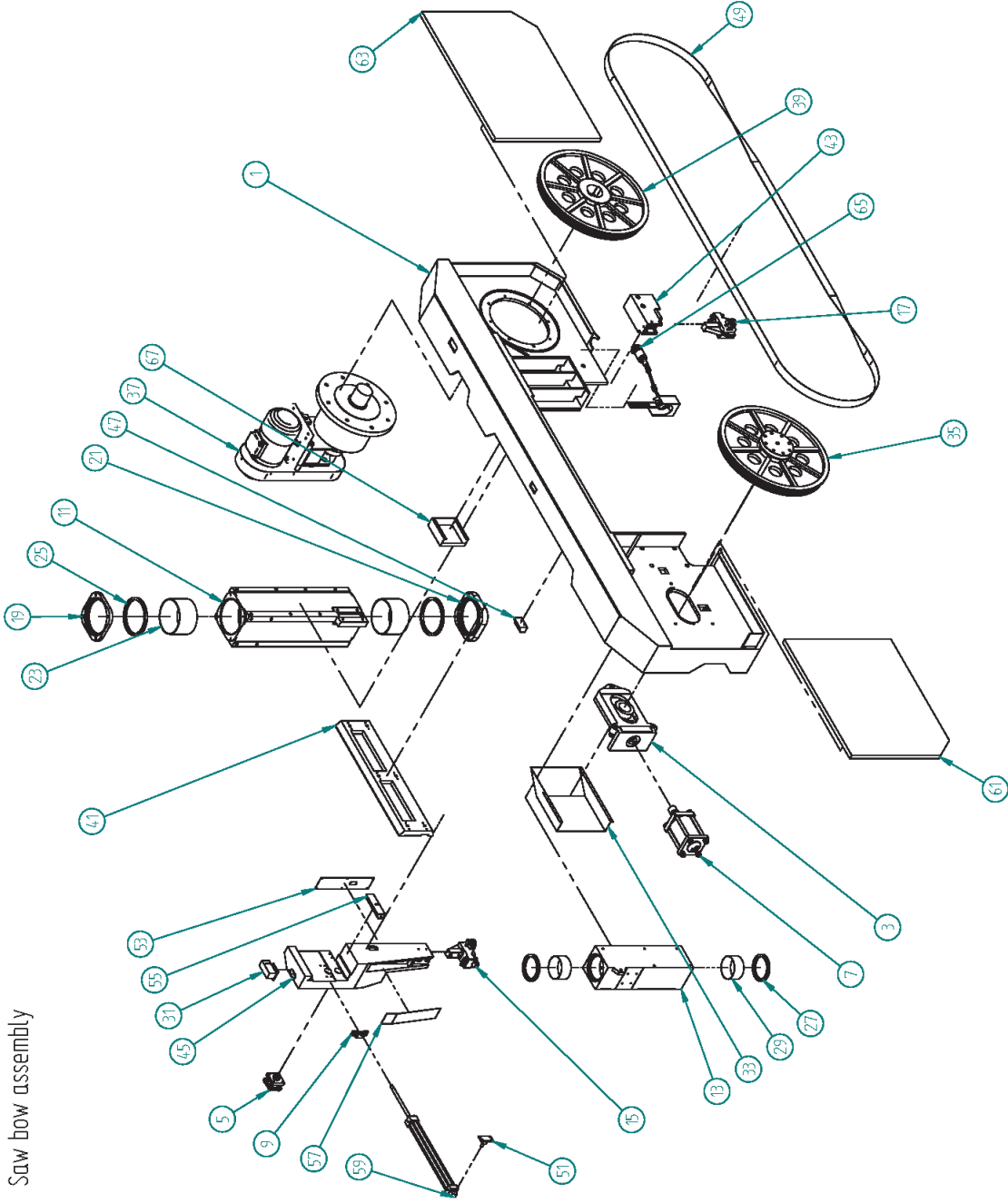

# SGL-30550

## Guide roller assembly (left)

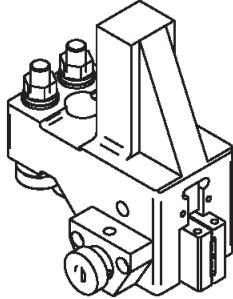

NO.	PART NO.	PART NAME	QTY
1	SGL-3055	Left guide wheel seat	1
3	SGL-3057	Left fixed insert	1
5	SGL-3058	Left movable insert	1
7	SGP-2019	Adjustment ring	1
9	SGP-2030	Carbide insert cylinder	1
11	SGT-3040	Carbide insert piston	1
13	SGT-3041	Spring washer	1
15	S1010-3141	Guide wheel shaft #1	1
17	S1010-3143	Guide wheel shaft #2	1
19	PP-59101	O Ring P-26	1
21	PP-59072	O Ring P-16	1
23	PP-52089	Ring S17	2
25	PP-14267	Bearing 62032R	4
27	PP-13119	Bearing 2215	1
29	AHA-0704A	Clamping seat	1
31	AGB-70410B	Pin	1
33	PQA-16	Nut	2
35	PPA-16	Washer	2
37	PQA-16	Spring washer	2

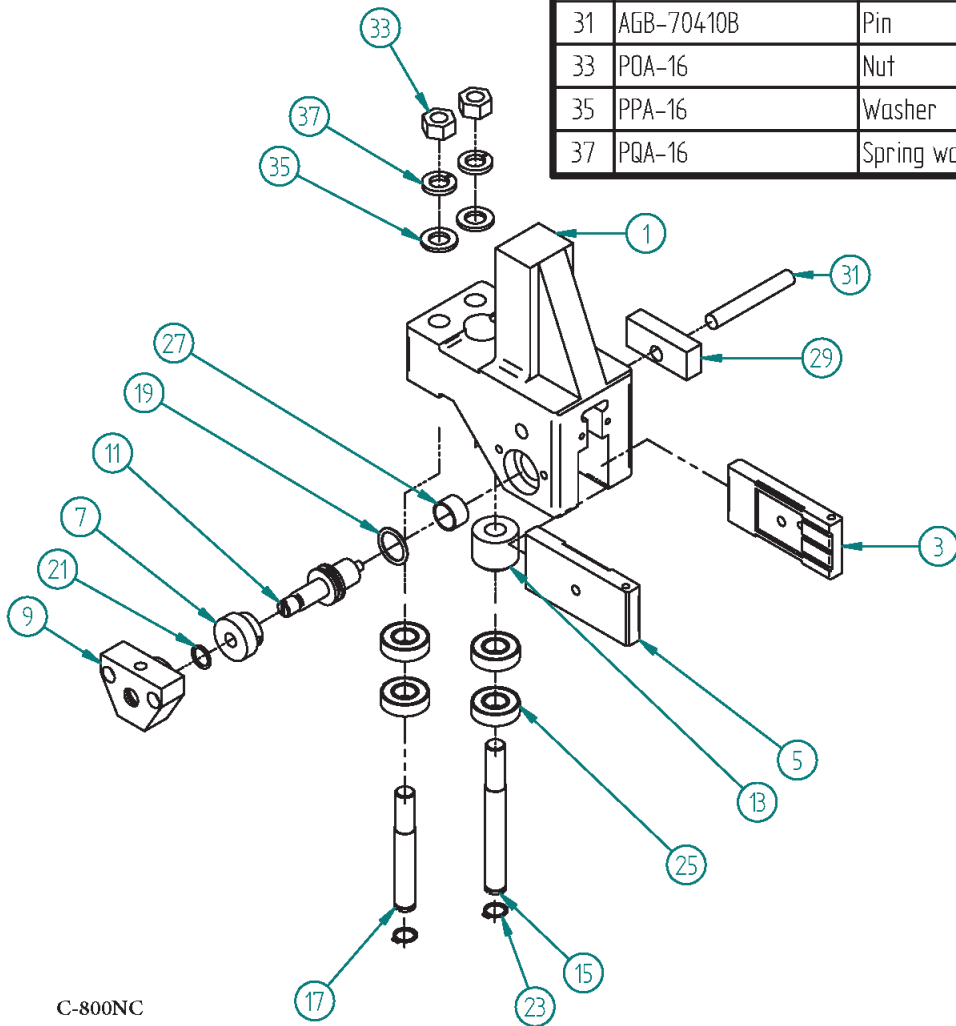

C-800NC

SGL-30560  
Guide roller assembly (right)

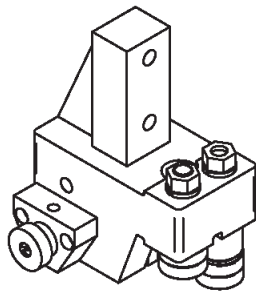

NO.	PART NO.	PART NAME	QTY
1	SGL-3056	Right guide wheel seat	1
3	AGB-70410A	Pin	1
5	AHA-0704A	Clamping seat	1
7	PP-13119	Bearing 2215	1
9	PP-52089	Ring S17	2
11	PP-59072	O Ring P-16	1
13	PP-59101	O Ring P-26	1
15	SGL-3059	Right fixed insert	1
17	SGL-3060	Right movable insert	1
19	SGL-3061	Bearing shaft (long)	1
21	SGL-3062	Bearing shaft (short)	1
23	SGP-2019	Adjustment ring	1
25	SGP-2030	Carbide insert cylinder	1
27	SGT-3040	Carbide insert piston	1
29	SGT-3041	Extended washer	1
31	PP-14267	Bearing 62032R	4
33	PQA-16	Nut	2
35	PQA-16	Spring washer	2

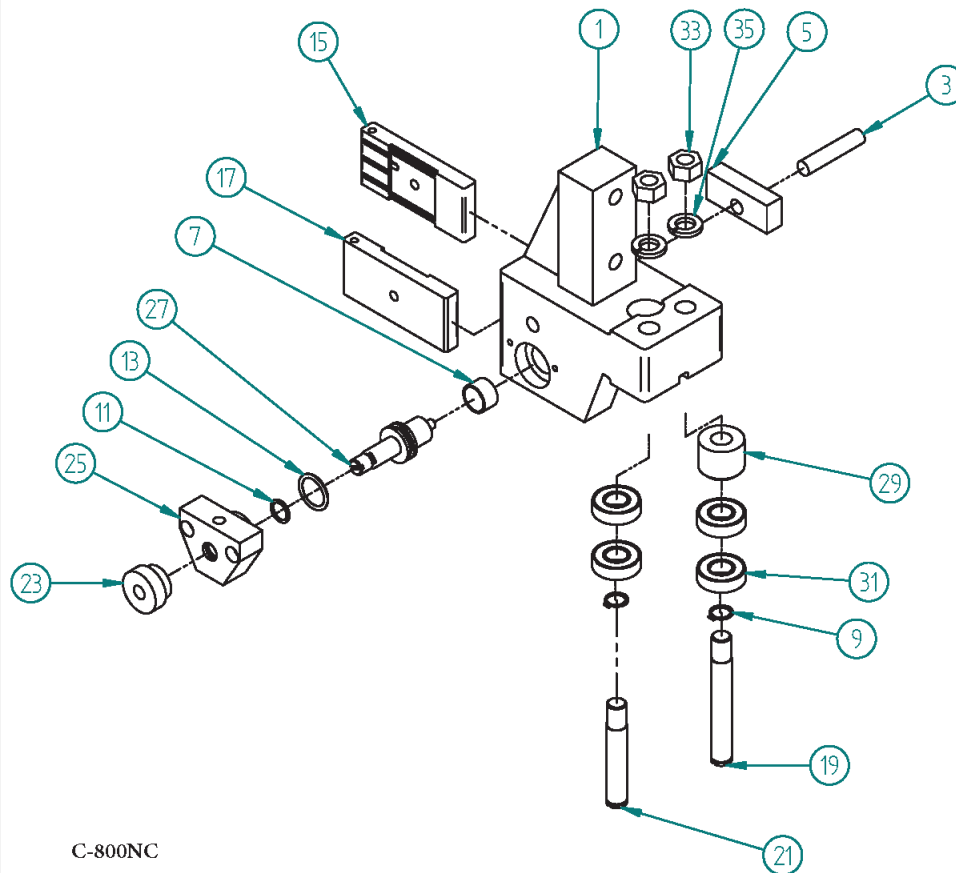

C-800NC

# Idle wheel assembly

NO.	PART NO.	PART NAME	QTY
1	V1316-3033	Idle wheel shaft	1
3	SGJ-2011	Idle wheel shaft fixed plate	1
5	PP-14630	Bearing 30220	2
7	PP-14920	Fixed nut AN20	1
9	PP-14970	Ring AW20	1
11	AGL-3002A	Idle wheel	1
13	C800H-3039	Bearing shield	1
15	NGE-3005A	Bearing cover	1
17	SDL-3012	Washer	1

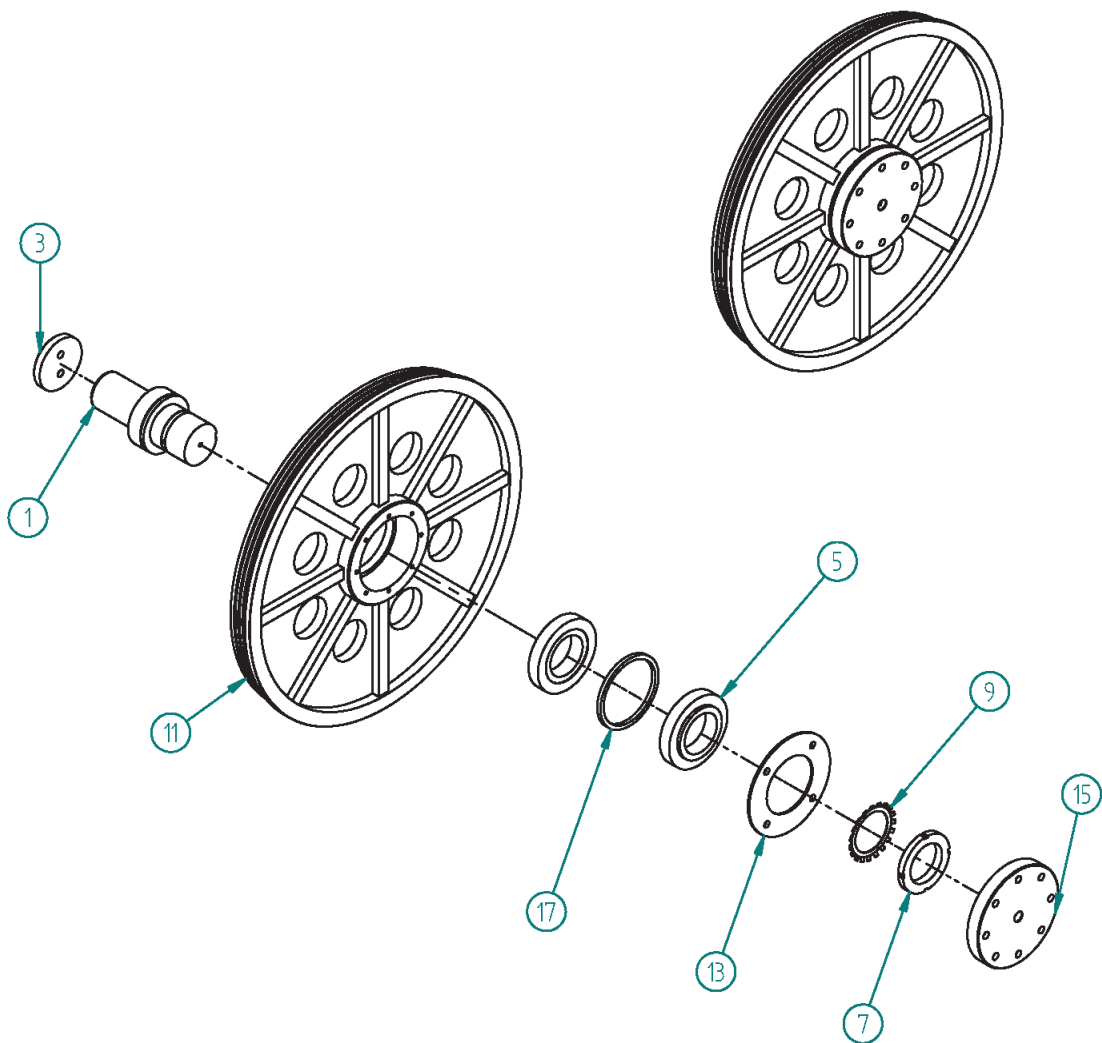

C-800NC

# Blade motor assembly

NO.	PART NO.	PART NAME	QTY
1	PP-16043	Planetary gearbox	1
3	PP-31668	Motor	1
5	SGJ-2040	Motor fixed seat	1
7	SGJ-2041	Motor plate	1
9	SGJ-2042	Motor rotation shaft	1
11	SGJ-2043	Motor movable shaft	1
13	SGJ-2045	Motor pulley	1
15	SGJ-2046	Gearbox pulley	1
17	SGJ-2047-1	Pulley cover	1
19	SGJ-2047-2	Pulley cover	1
21	SGJ-2048	Pulley cover bracket	2
23	SGJ-2049	Pulley stopper plate	2
25	SGN-2041	Motor adjustment rod	1
27	SGO-3038	Motor base accessory	1

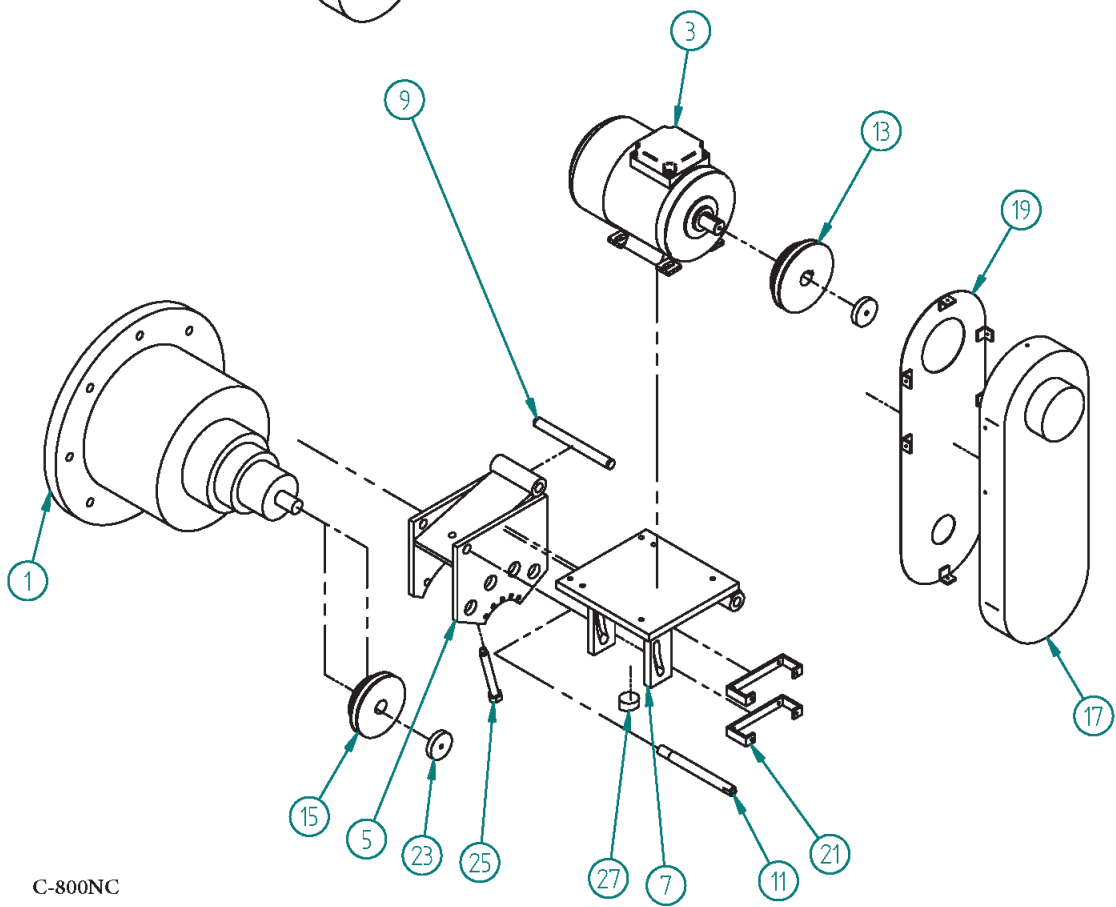
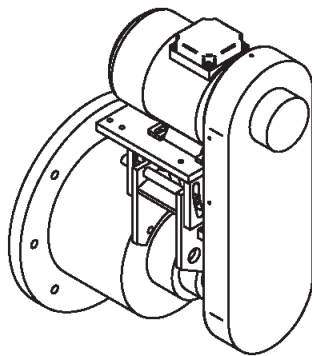

C-800NC

# Wire brush assembly

NO.	PART NO.	PART NAME	QTY
1	PP-31640-1	Hydraulic motor	1
3	PP-58002	Wire brush	2
5	SGJ-2052	Wire brush shaft sleeve	1
7	SGJ-2053A	Connecting rod	1
9	SGJ-2059A	Wire brush shaft	1
11	SGL-3016	Wire brush cover	1
13	PP-15010	Universal joint	2
15	PP-13025	DU bushing 1215	2

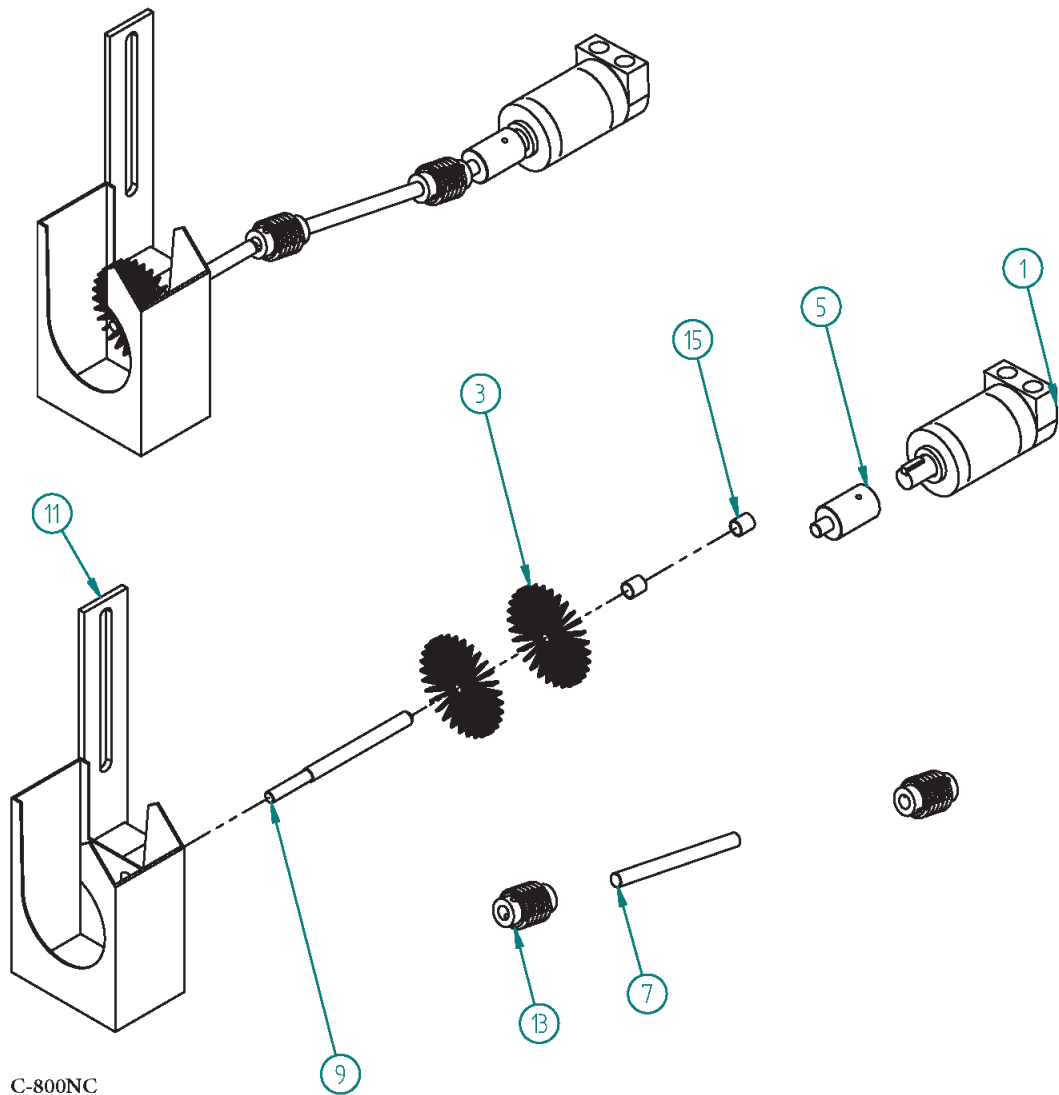

Bed Assembly

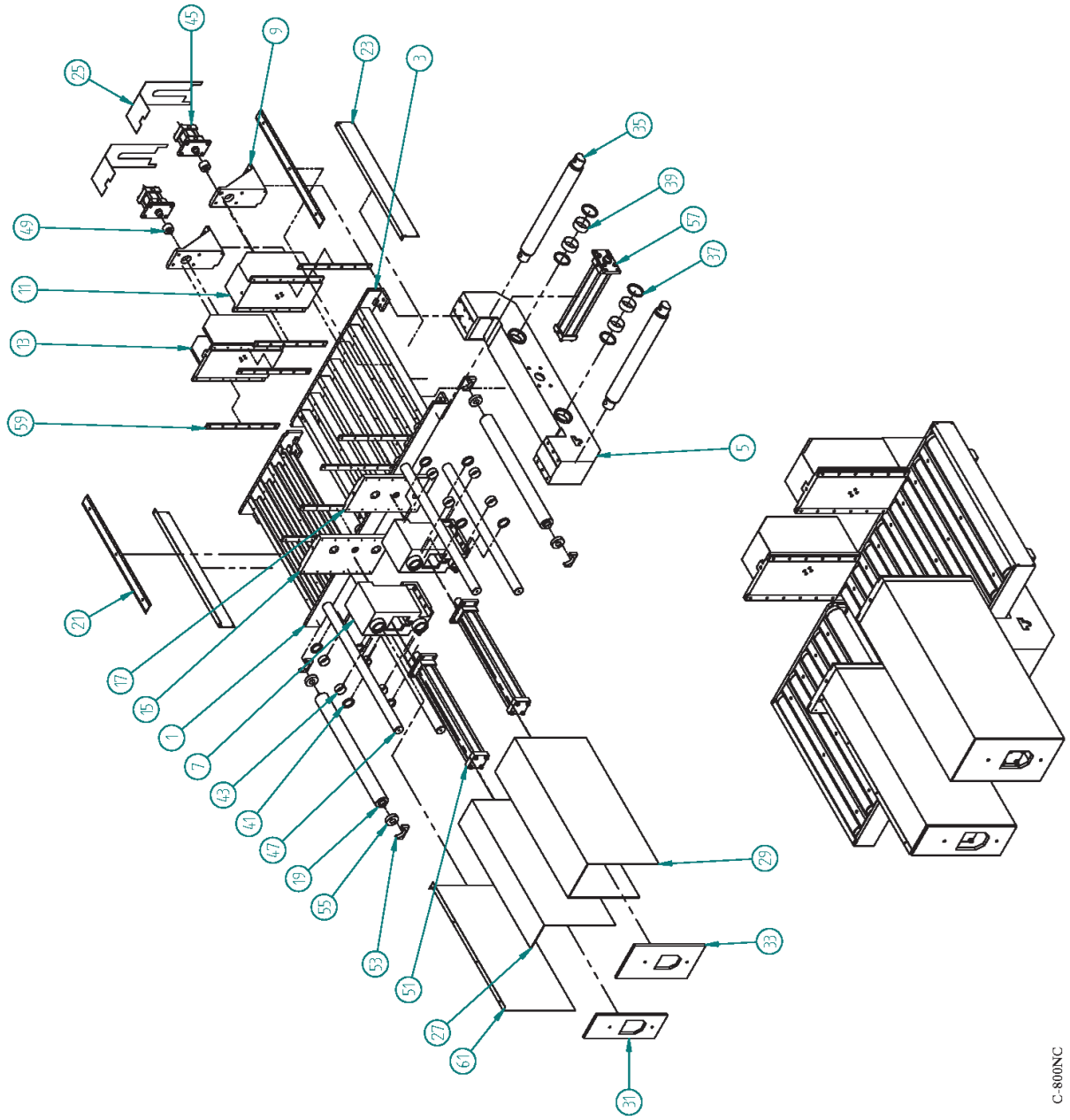

NO.	PART NO.	PART NAME	QTY
1	CGL-1005	Workbed roller frame #1	1
3	CGL-1006	Workbed roller frame #2	1
5	CGL-1013	Rear vise seat	1
7	CGL-1014	Movable vise head	2
9	C800H-2315	Fixed vise cylinder seat	2
11	C800H-2221	Feeding fixed vise	1
13	C800H-2201	Fixed vise	1
15	CGL-1018A	Movable vise	1
17	CGL-1018B	Movable vise	1
19	CGL-1019	Workbed roller	13
21	CGL-1020	Roller interval plate A	11
23	CGL-1022	Workbed front/rear fence	2
25	CGL-1023C	Fixed vise cover	2
27	CGL-1024	Front movable vise cylinder cover	1
29	CGL-1025	Rear movable vise cylinder cover	1
31	CGL-1026-1	Movable vise balance plate #1	1
33	CGL-1026-2	Movable vise balance plate #2	1
35	AGE-1004	Feeding slide shaft	2
37	PP-51143	Dust seal	4
39	PP-13289	DU bushing 9040	4
41	PP-51191	Dust seal	8
43	PP-13225	DU bushing	8
45	PP-43474A	Cylinder	2
47	AGE-1015	Movable vise slide shaft	4
49	AGE-1024	Vise piston connector	2
51	PP-43413A	Cylinder	2
53	AGE-1102	Roller bearing seat	26
55	PP-14141	Bearing 6307ZZ	26
57	PP-43414A	Cylinder	1
59	CGL-1074	Vise plate	8
61	CGL-1052	Front movable vise cylinder side cover	1



# Control box assembly

NO.	PART NO.	PART NAME	QYT
1	NDD-1303	Control box base	1
3	SVJ-3201B	Control box	1
5	C800H-1321	Control panel	1
7	C800H-1323	Control panel frame	1
9	C800H-1329	Flow valve seat	1
11	PP-43115	Flow valve FG0230	1

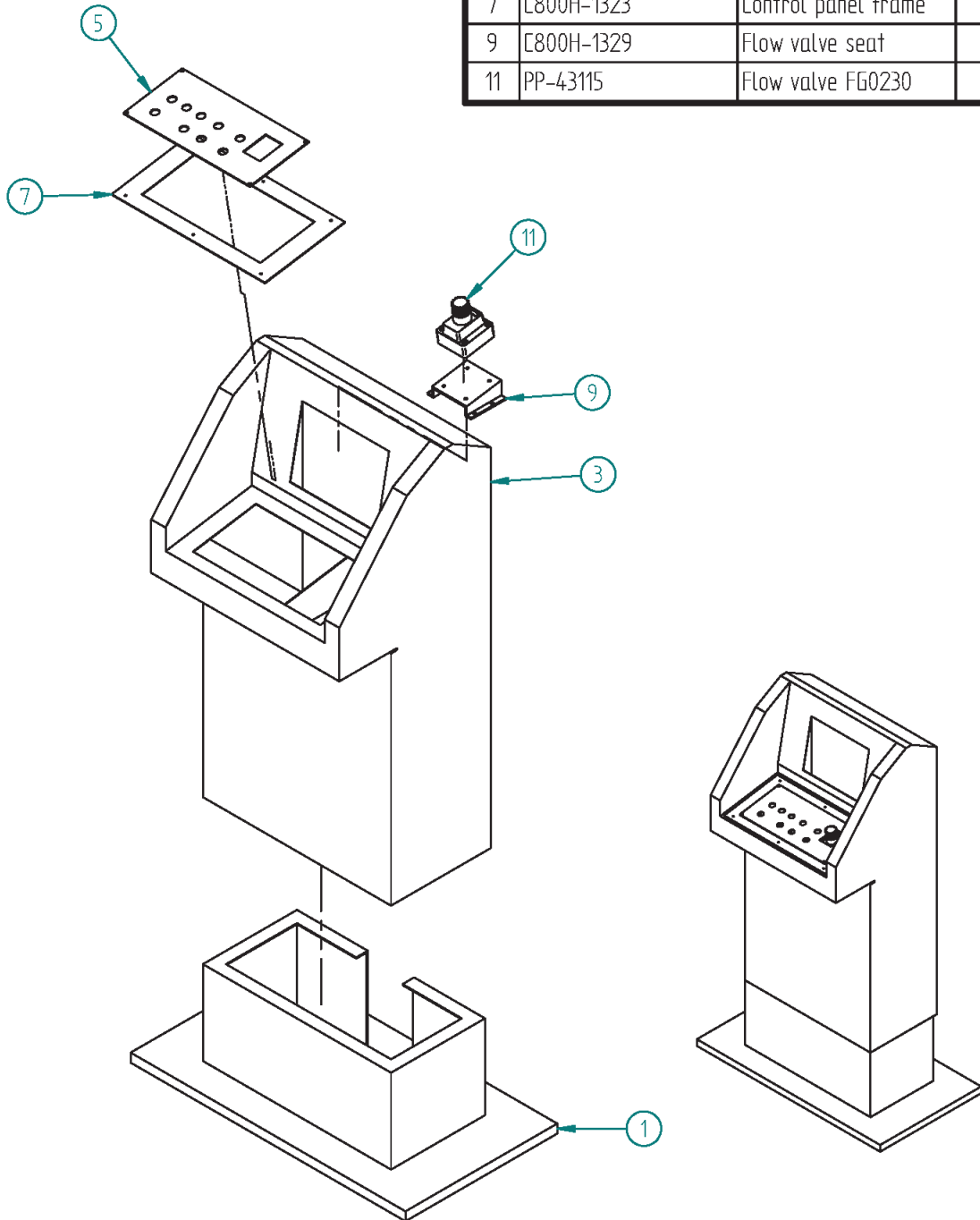

C-800NC

CGL-C001

NO.	PART NO.	PART NAME	QTY
1	AGE-1030B	Chip conveyor body	1
3	AGL-1060A	Motor seat	1
5	AGL-1061	Motor cover	1
7	C1000H-4003	Chip spiral	1
9	AHA-2022B	Spiral shaft	1
11	AHB-2019A	Driving chain wheel.1	1
13	AHB-2019B	Driving chain wheel.2	1
15	AHB-2020B	Bearing seat	1
17	AHB-2023A	Chain wheel shaft	1
19	AHB-2026	Connecting plate	1
21	CGL-1027	Chip collector	1
23	CGL-1039	Fixed bracket	1
25	PP-14003	Bearing 6202WV	2
27	PP-31640-1	Hydraulic motor	1
29	PP-43117	Flow valve	1
31	PP-52097	Ring S15	1
33	PP-58106	Ring R35	1
35	SGL-2118	Chip shield	1
37	SGL-2119	Chip shield seat	1

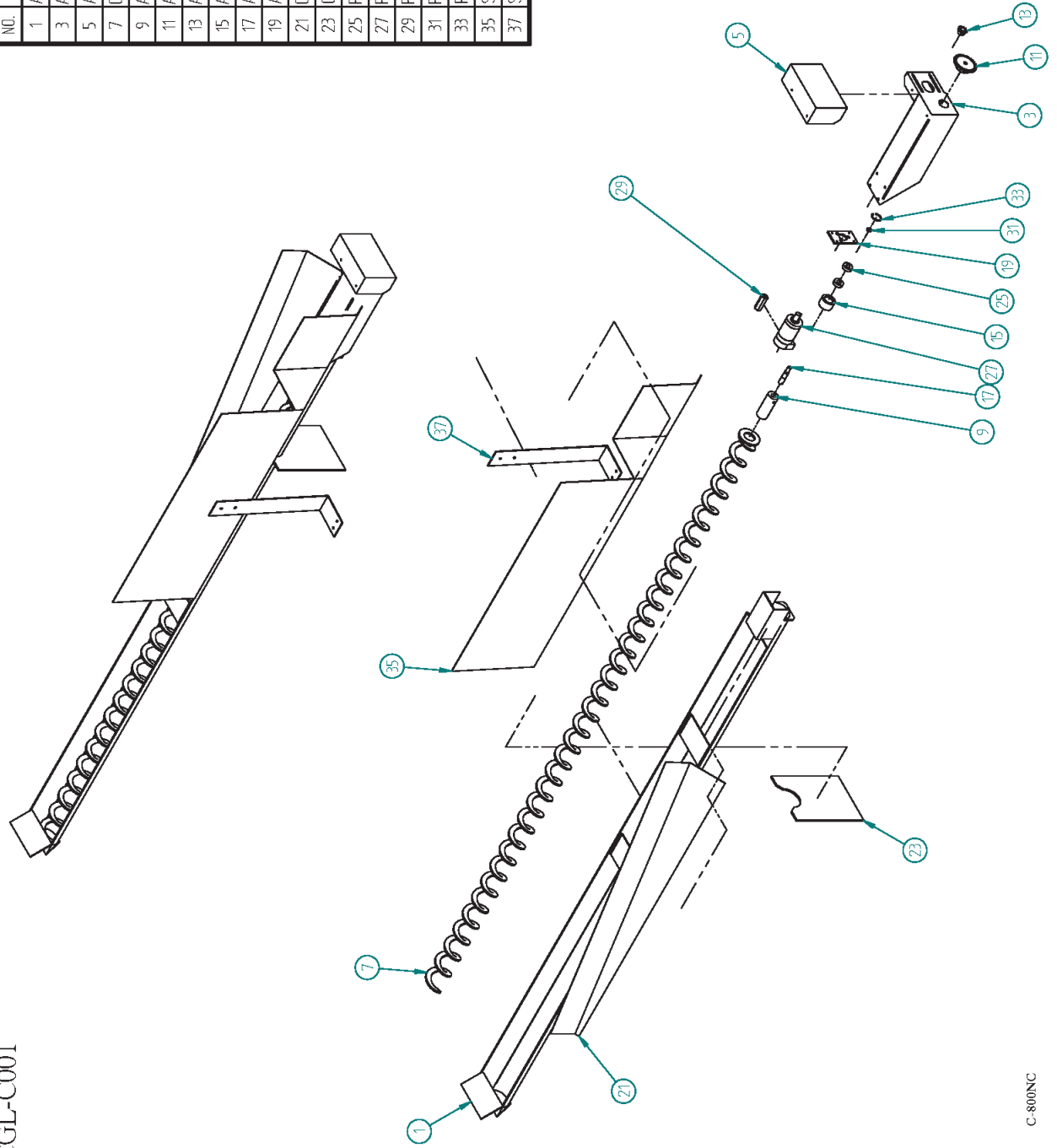

C-500NC

# SGJ-21010

NO.	PART NO.	PART NAME	QTY
1	SGJ-2101	Tensioner sliding seat	1
3	SGJ-2102	Tensioner sliding plate	1
5	AGE-2044	Tensioner sliding pressure plate	2
7	PBA-12-30	Bolt	8
9	SGN-3034	Tensioner adjusting bolt	3

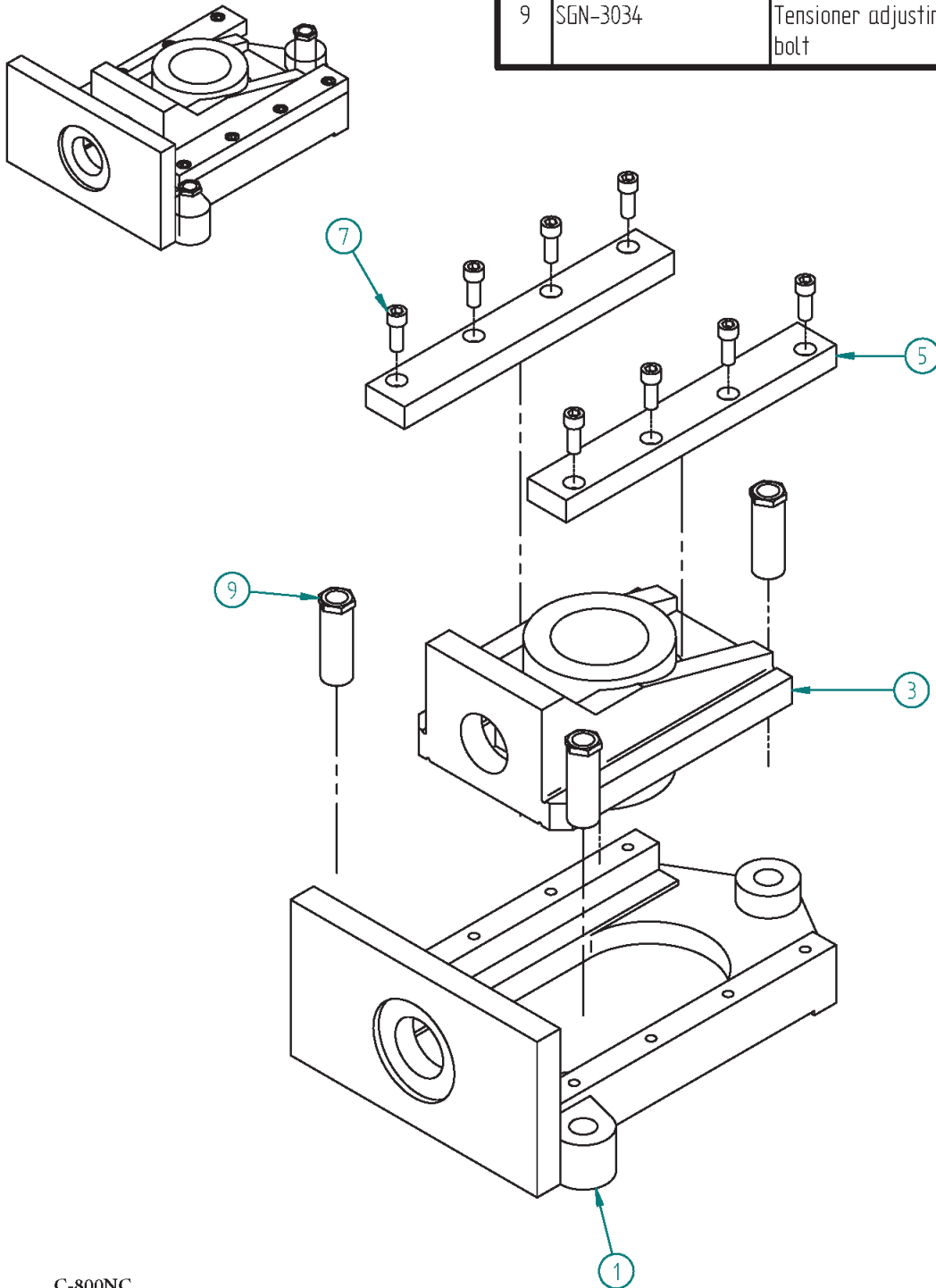

C-800NC

# SGJ-21030-1

NO.	PART NO.	PART NAME	QYT
1	SGJ-2103	Tensioner front cover	1
3	SGJ-2104	Tensioner back cover	1
5	SGJ-2105	Tensioner piston and shaft	1
7	SGJ-2106	Tension tube	1
9	SGJ-2107	Tension shaft	4
11	PP-13249	DU bushing	1
13	PP-59240	O Ring	2
15	PP-59803	O Ring	2
17	PP-59156	O Ring P-60	1
19	PQA-20	Spring washer	8
21	PQA-20	Nut	8

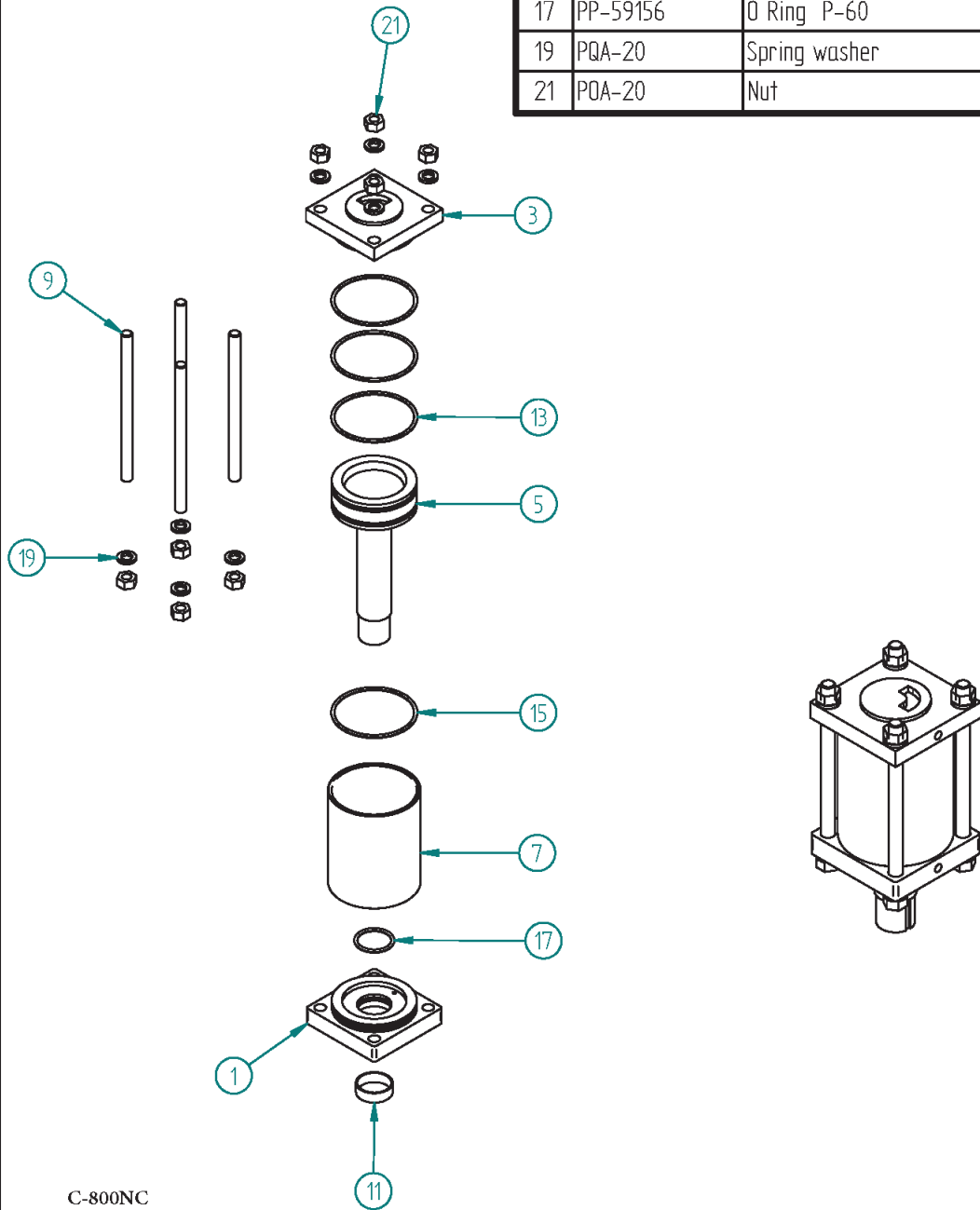

C-800NC

# SGL-33010

NO.	PART NO.	PART NAME	QYT
1	SGL-3303A	Vibration damper seat	1
3	SGL-3305	Shaft	1
5	SGL-3397	Vibration damper seat	1
7	SGL-3302	Shaft	1
9	SGL-3301	Vibration roller	1
11	PP-91369	Pin $\Phi$ 10x55L	1
13	PP-58111	Ring R47	2
15	PP-57403	Spring TB-1625	1
17	PP-14507	Bearing 2204	1
19	AGB-3309	Bolt	1
21	AGB-3308	Rubber ring	1
23	AGB-3307	Grease cover	1
25	AGB-3306N	Spring holder	1
27	PP-14267	Bearing 62032R	5
29	PQA-10	Spring washer	1
31	PBA-10-16	Bolt	1
33	PPA-10	washer	1
35	PQA-16	Nut	1
37	PQA-16	Spring washer	1
39	PBA-5-12	bolt	1
41	PBA-6-50	bolt	1

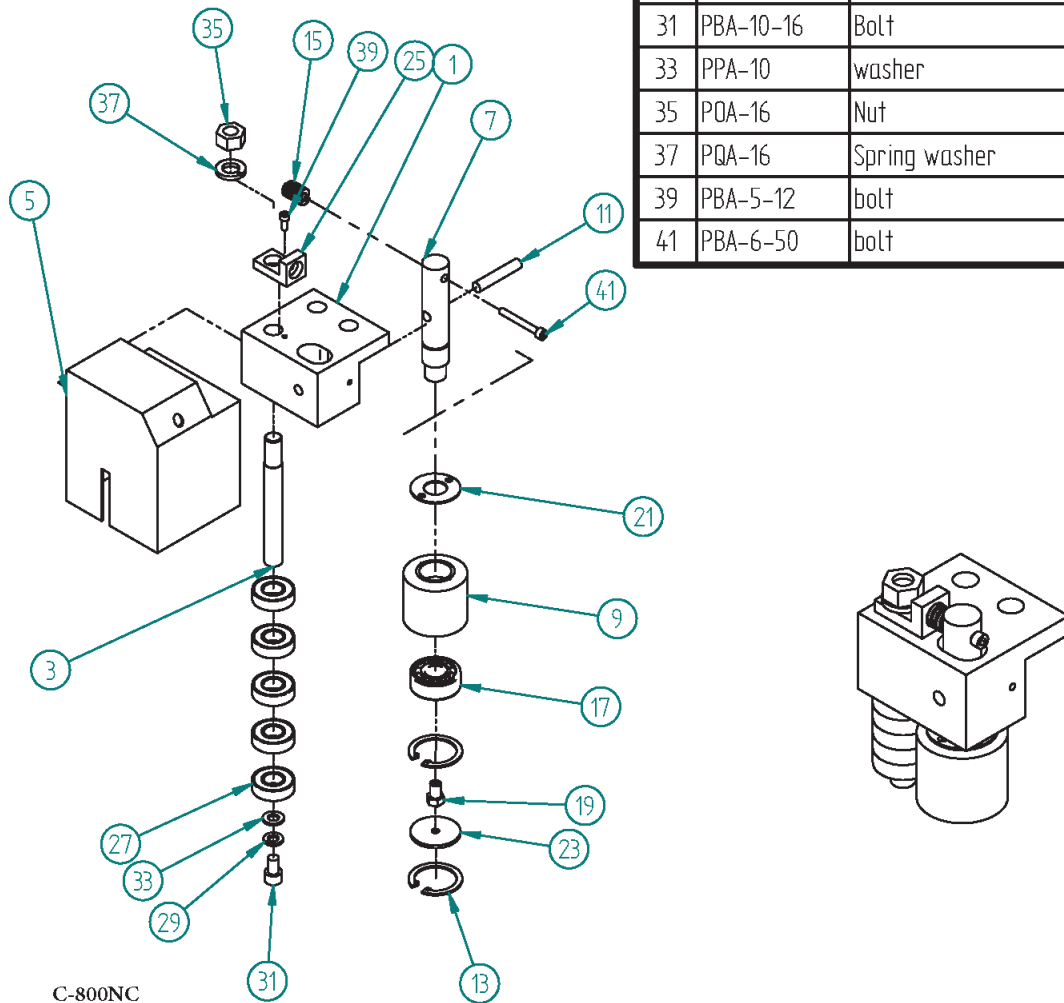

# SGJ-32800-1

NO.	PART NO.	PART NAME	QYT
1	SGJ-2019	Guide arm cylinder front cap	1
3	PP-13195	DU bushing 3020	1
5	PP-59110	O ring -30	1
7	PP-59570	O ring -65	1
9	AGE-2019	Spring	1
11	SGJ-2016	Guide arm locked piston	1
13	PP-59156	O Ring P-60	2
15	SGJ-2017	Guide arm lock cylinder	1
17	SGJ-2018	Guide arm cylinder rear cap	1
19	PBA-10-75	bolt	4
21	PP-51189	Dust seal	1

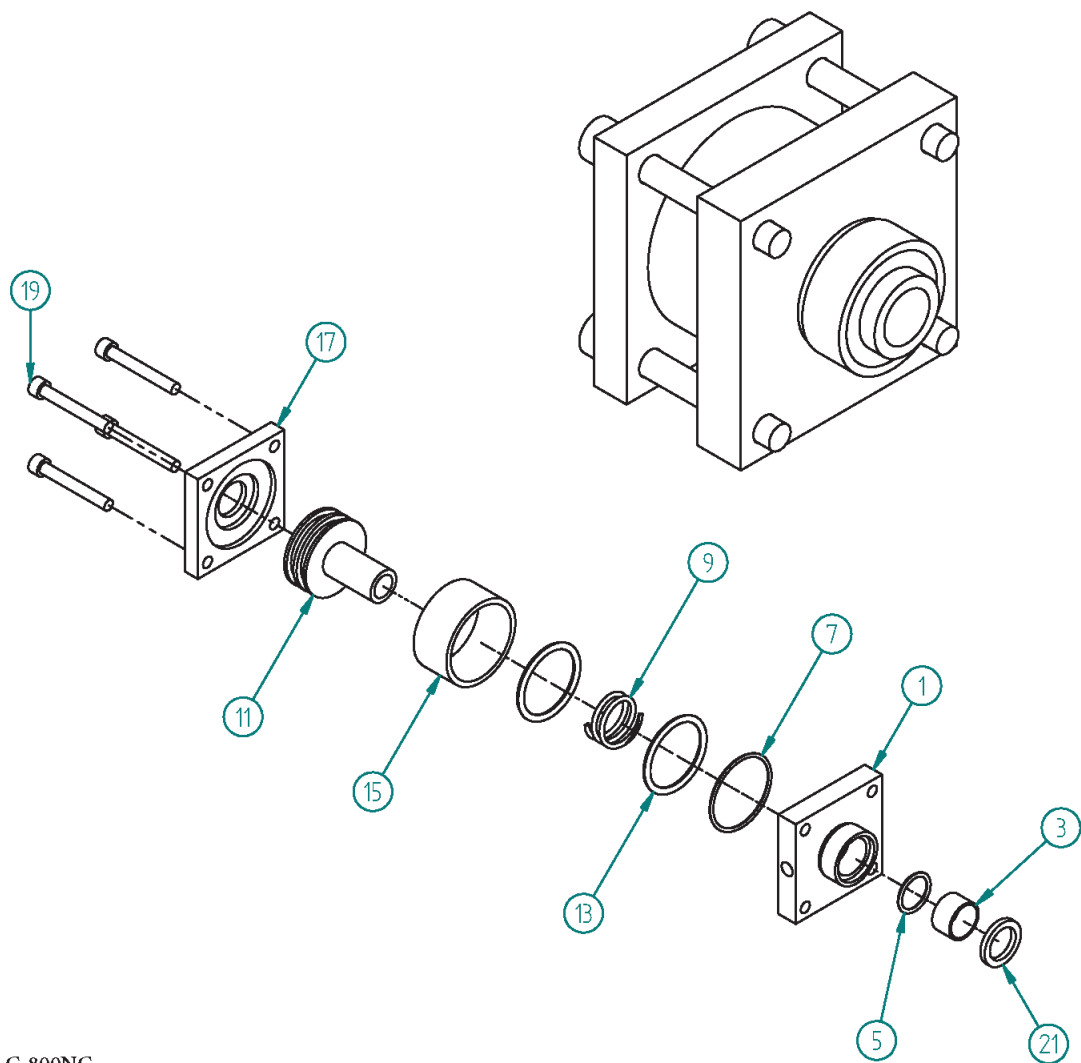

# AGB-707270

NO.	PART NO.	PART NAME	QTY
1	AGB-70727	Oil filter body	1
3	AGB-70730	Filter	1
5	O 型環	O Ring	1
7	AGB-70729	Filter spring	1
9	AGB-70728	Filter cap	1
11	PQA-6	spring washer	3
13	PBA-6-25	bolt	3

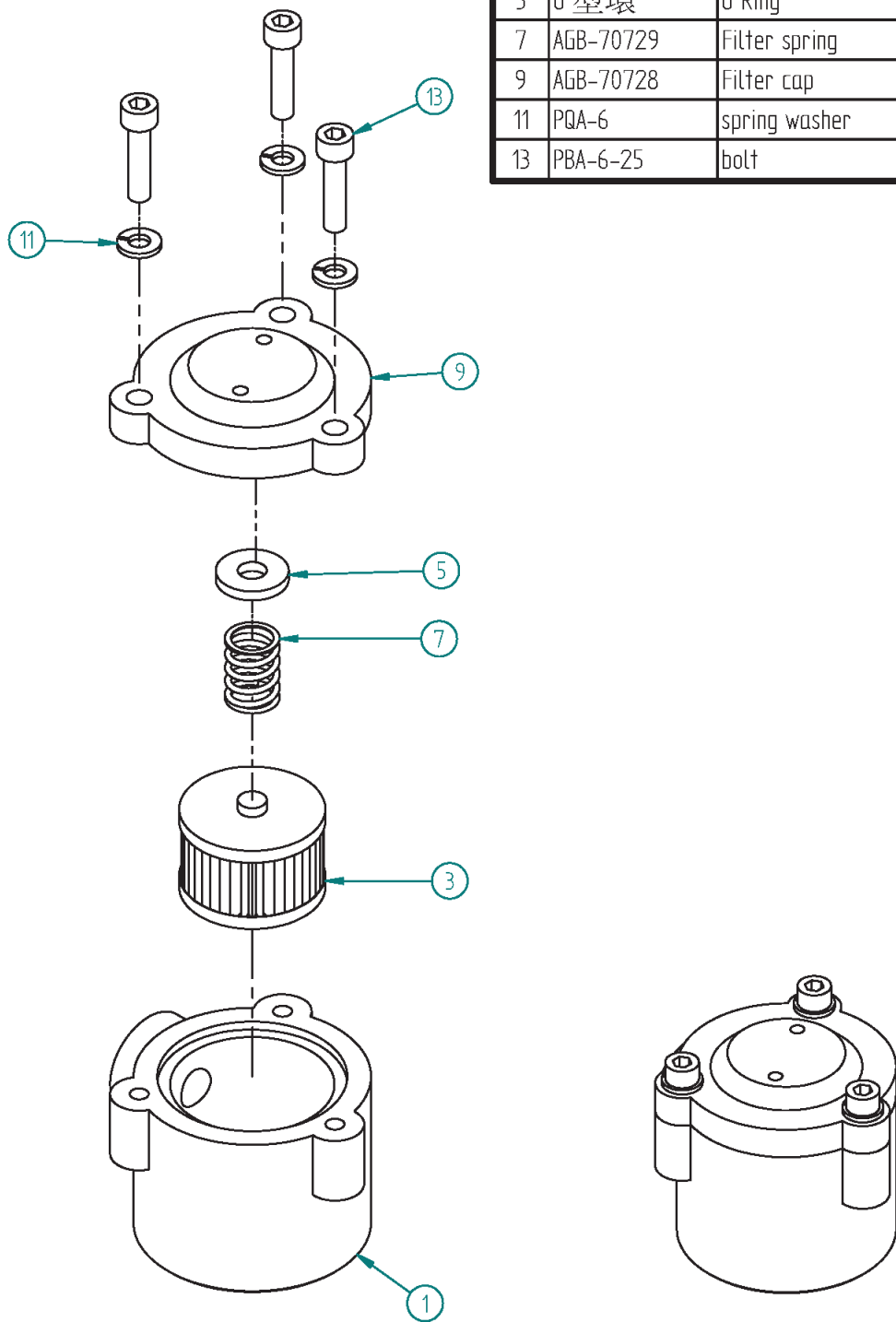

C-800NC

050PR-800DM

NO.	PART NO.	PART NAME	QTY
1	OPR-7202GA	Electric roller Table	1
3	OPR-7201A	Roller	8
5	OPR-7208	Drive sprocket	1
7	OPR-7209	Transmission sprocket	8
9	OPR-7210A	Drive sprocket cover	1
11	OPR-7211AA	Chain wheel cover	1
13	OPR-7212	Crutch cover	1
15	PP-14257	Bearing 6211W	16
17	PP-31645C	Gearbox	1
19	OPR-6205A	Roller rack	16
21	OPR-6206	Roller rack seat	16
23	OPR-6207G	Side shield	4
25	AHL-0152	Table stand adjustment rod	6
27	AHR-1055	Table stand pad	6

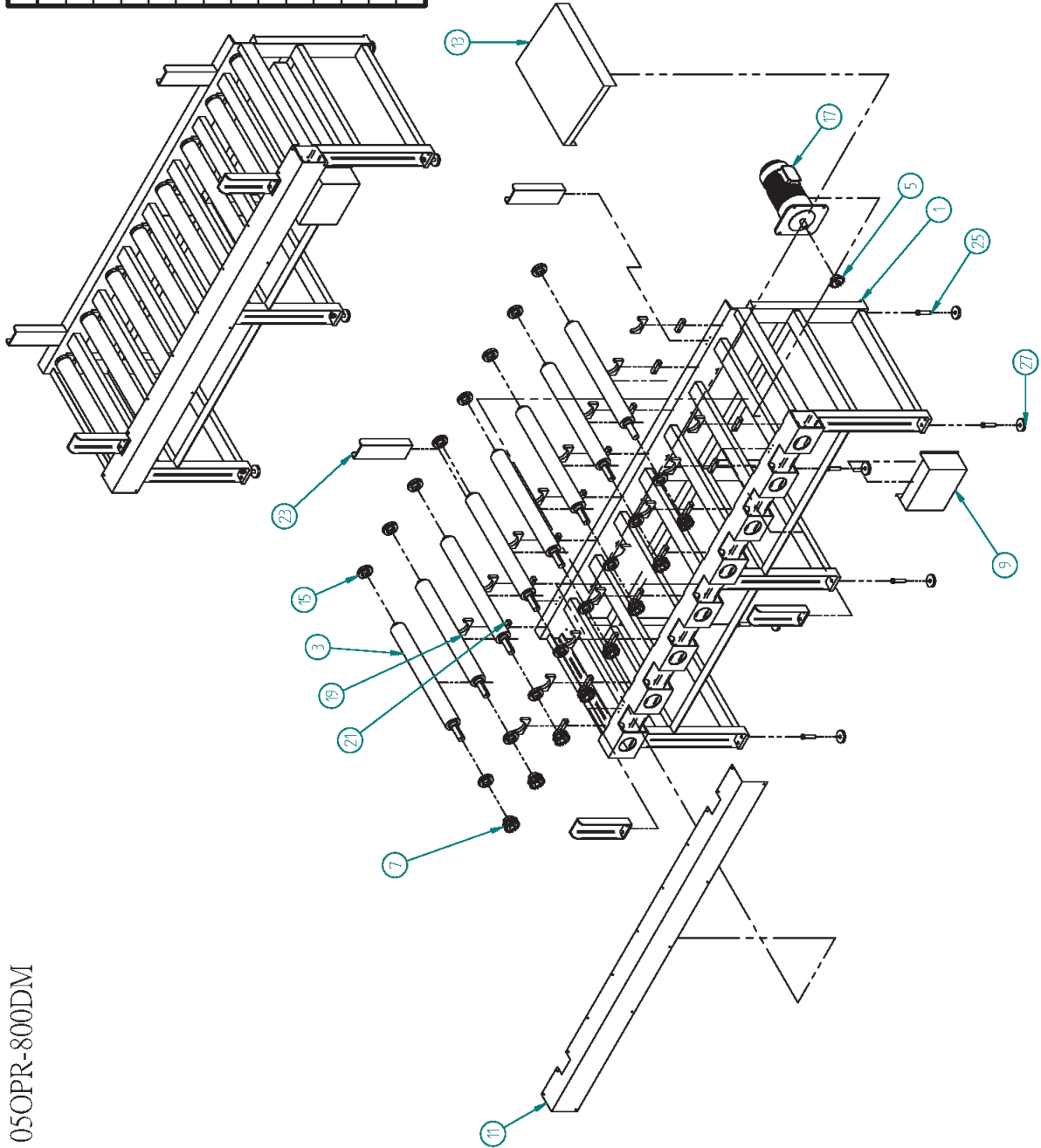

C-500NC



C-1000NC

NO.	PART NO.	PART NAME	QTY
1	Base Assembly	Base Assembly	1
3	Bed Assembly	Bed Assembly	1
5	Saw bow assembly	Saw bow assembly	1
7	C1000H-C001	Chip conveyor assembly	1
9	Control box assembly	Control box assembly	1

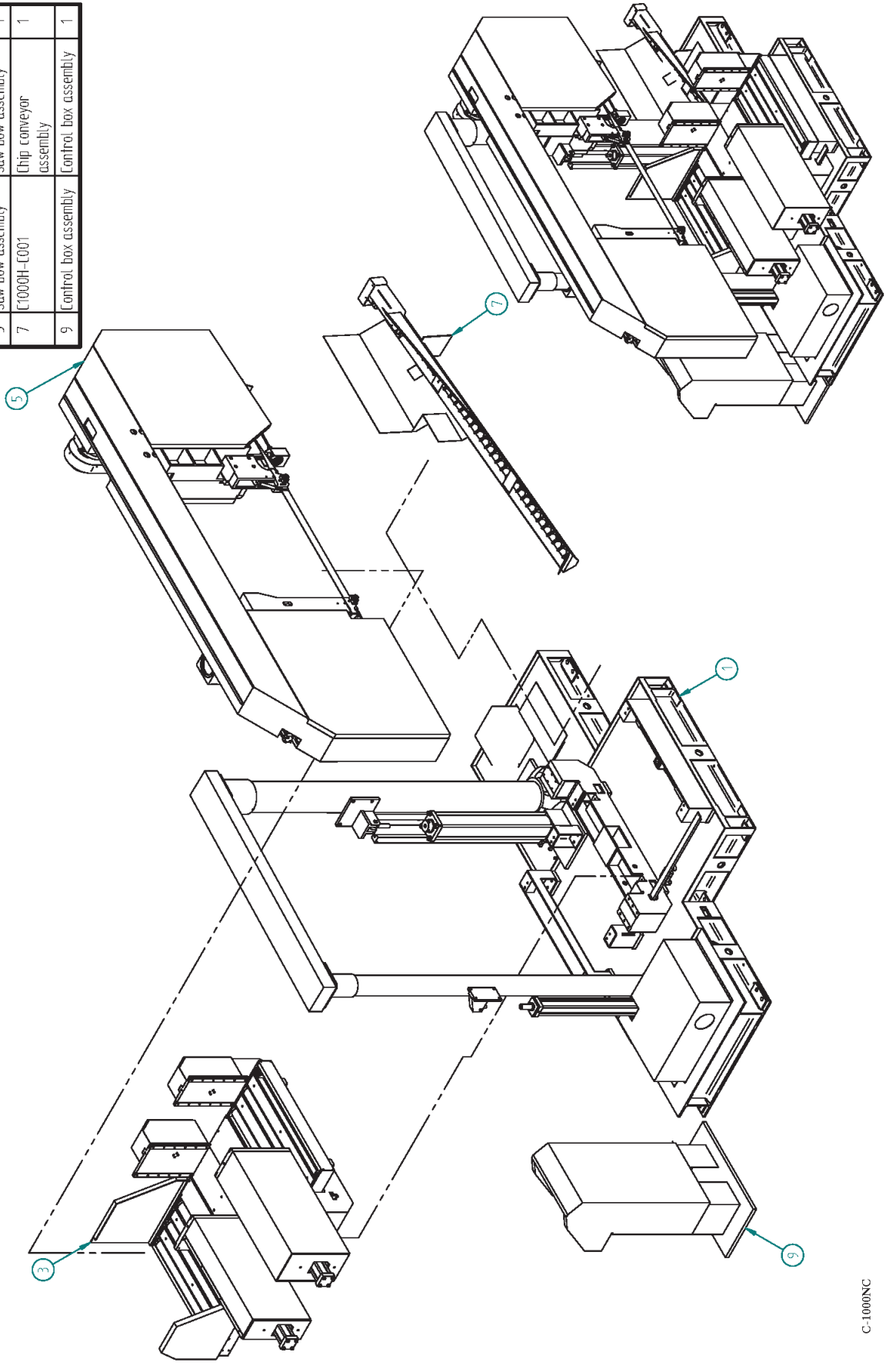

C-1000NC

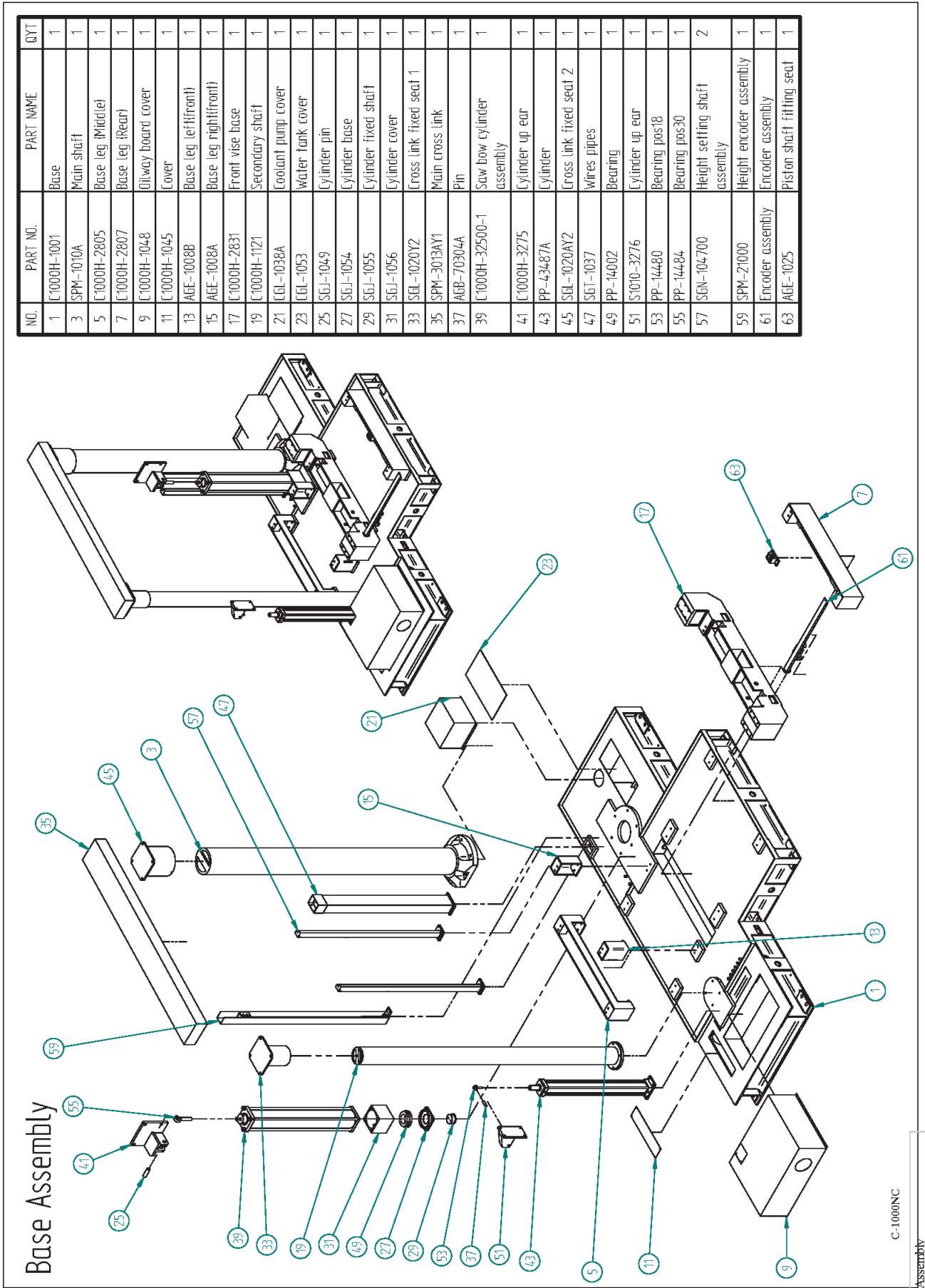

NO.	PART NO.	PART NAME	QTY
1	C1000H-1001	Base	1
3	SPM-1010A	Main shaft	1
5	C1000H-2805	Base leg (Middle)	1
7	C1000H-2807	Base leg (Rear)	1
9	C1000H-1048	Oilway board cover	1
11	C1000H-1045	Cover	1
13	AGE-1008B	Base leg (left/front)	1
15	AGE-1008A	Base leg (right/front)	1
17	C1000H-2831	Front vise base	1
19	C1000H-1121	Secondary shaft	1
21	LGL-1038A	Coolant pump cover	1
23	LGL-1053	Water tank cover	1
25	SGJ-1049	Cylinder pin	1
27	SGJ-1054	Cylinder base	1
29	SGJ-1055	Cylinder fixed shaft	1
31	SGJ-1056	Cylinder cover	1
33	SGJ-1020Y2	Cross link fixed seal 1	1
35	SPM-3013AY1	Main cross link	1
37	AGB-70304A	Pin	1
39	C1000H-32500-1	Saw bow cylinder assembly	1
41	C1000H-3275	Cylinder up ear	1
43	PP-43487A	Cylinder	1
45	SGJ-1020AY2	Cross link fixed seal 2	1
47	SGT-1037	Wires pipes	1
49	PP-14002	Bearing	1
51	S1010-3276	Cylinder up ear	1
53	PP-14480	Bearing pos18	1
55	PP-14484	Bearing pos30	1
57	SGN-104700	Height setting shaft assembly	2
59	SPM-21000	Height encoder assembly	1
61	Encoder assembly	Encoder assembly	1
63	AGE-1025	Piston shaft fitting seal	1

C-1000NC

Base Assembly

# SPM-21000

NO.	PART NO.	PART NAME	QYT
1	SPM-2111	Tooth bar fixed seat 1	1
3	SPM-2109	Tooth bar	1
5	SPM-2113	Tooth bar fixed seat 2	1
7	SGT-3057	Tooth bar cover	1
9	SGO-1039	Up limist switch seat	1
11	PP-13020	Du bushing	1
13	AHA-1565	Spring	1
15	AHA-1560	Inch wheel	1
17	AGB-70536	Encoder fixed seat 2	1
19	AGB-70535	Encoder fixed seat 1	1
21	PP-90492	Encoder	1

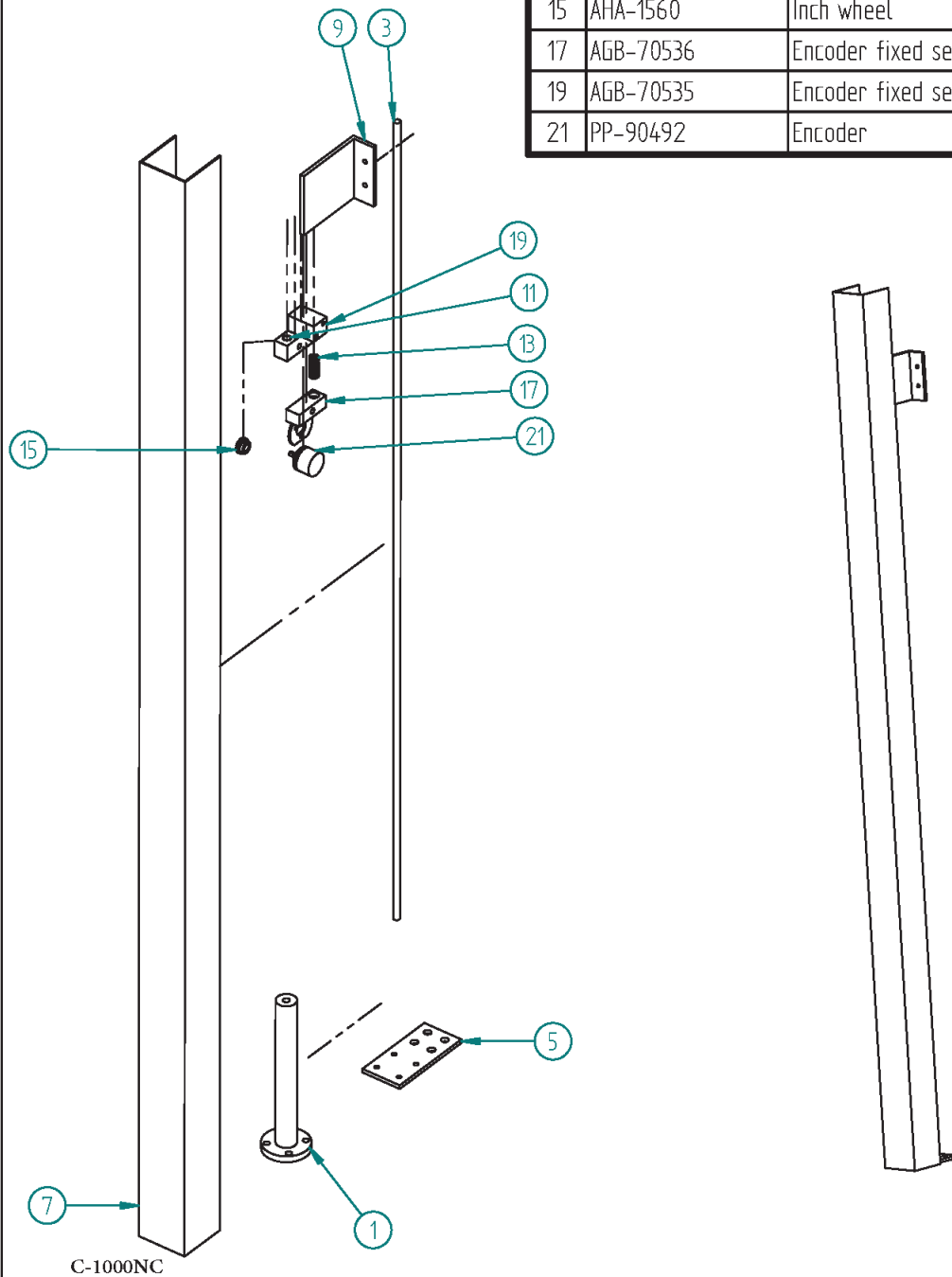

# Encoder assembly

NO.	PART NO.	PART NAME	QYT
1	AHA-1563	Encoder seat	1
3	AHA-1564	Tooth bar seat	1
5	AHA-1565	Spring	1
7	AHA-1561-2	Tooth bar	1
9	AHA-1562	Movable plate	1
11	AHA-1560	Inch wheel	1
13	PP-90492	Encoder	1
15	PP-90492-1	Coupling	1
17	AGB-70539	Encoder plate	1
19	L800H-2119	Teeth bar cover	1

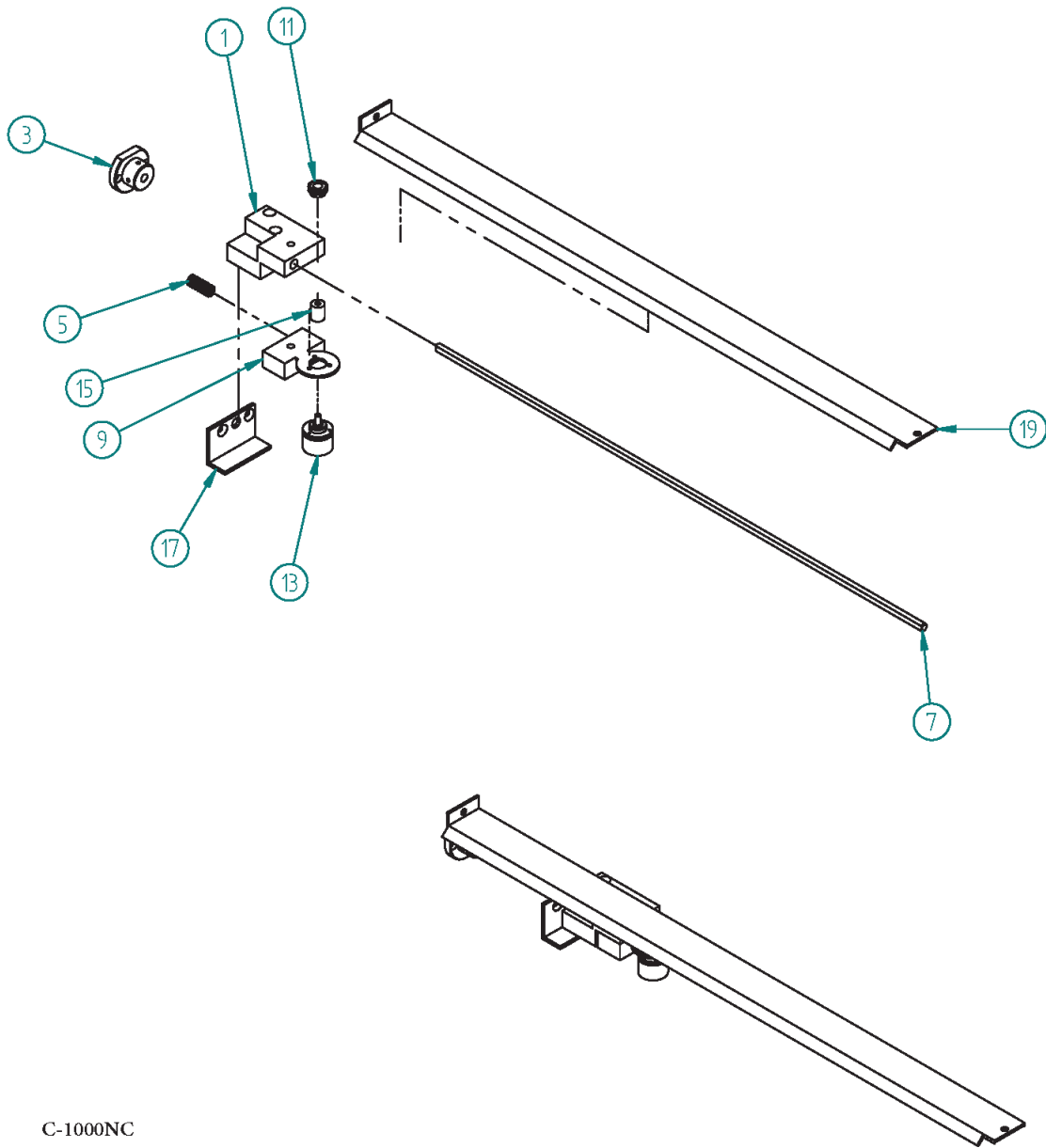

C-1000NC

# Bed Assembly

NO.	PART NO.	PART NAME	QTY
1	C1000H-2871A	Bed roller seat(Front)	1
3	C1000H-2873A	Bed roller seat(Back)	1
5	C1000H-2875	Roller	6
7	C1000H-2877A	Blade line plate 1	1
9	C1000H-2879A	Blade line plate 3	1
11	C1000H-2823	Cover	2
13	C1000H-2825	Spacer 2	2
15	C1000H-2827	Spacer 3	2
17	AGE-1004	Feeding sliding shaft	2
19	C1000H-2818A	Blade line plate 2	1
21	C1000H-2833	Rear vise base seal	1
23	C1000H-2835C	Fixed vise	1
25	C1000H-2843	Front movable vise	1
27	CGI-1074	Movable vise up seat	2
29	CGI-1076	Fixed vise cylinder seat	2
31	CGI-1077B	Feeding fixed vise	1
33	CGI-1078B	Movable vise	1
35	CGI-1023C	Rear fixed vise cover	2
37	CGI-1024	Front movable vise cover	1
39	PP-51143	Dust seal	4
41	PP-13289	Du bushing	4
43	CGI-1025	Rear movable cylinder cover	1
45	CGI-1059	Side cover (right)	1
47	CGI-1060	Side cover (left)	1
49	CGI-1074	Vise plate	8
51	PP-43473A	Cylinder	2
53	PP-43474A	Cylinder	1
55	PP-43474A	Cylinder	2
57	AGE-1024	Piston fitting	2
59	AGE-1075	Sliding shaft	4
61	PP-51191	Dust seal	8
63	PP-13225	Du bushing	8
65	CGI-1026-1	Weight balancer	1
67	CGI-1026-2	Weight balancer	1
69	CGI-1052	Vise side cover	1
71	SPM-2005A	Roller seat	12
73	PP-14143	Bearing	12

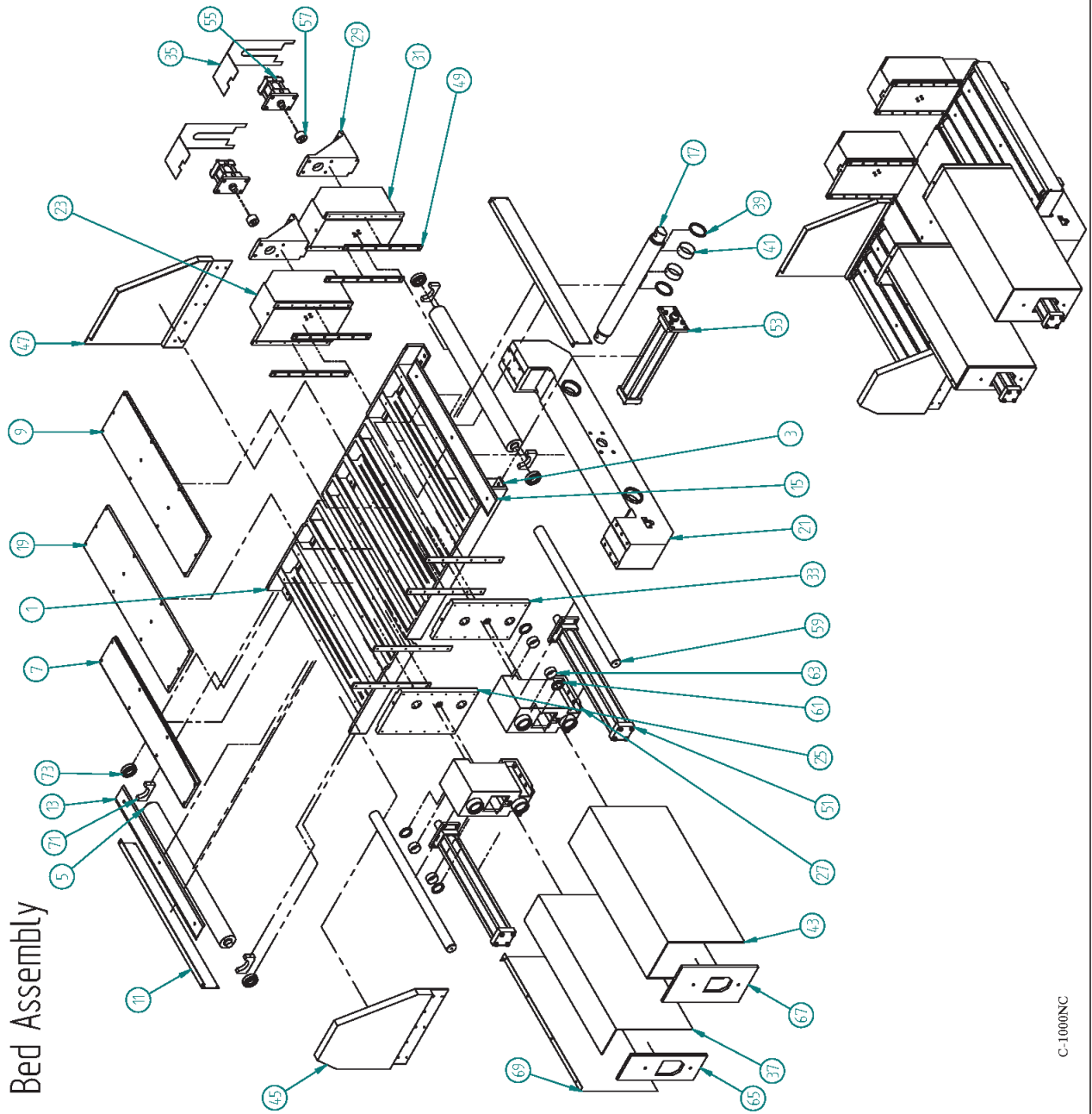

C-1000NC

# Bed Assembly

NO.	PART NO.	PART NAME	QTY
1	C1000H-2871A	Bed roller seat(Front)	1
3	C1000H-2873A	Bed roller seat(Back)	1
5	C1000H-2875	Roller	6
7	C1000H-2877A	Blade line plate 1	1
9	C1000H-2879A	Blade line plate 3	1
11	C1000H-2823	Cover	2
13	C1000H-2825	Spacer 2	2
15	C1000H-2827	Spacer 3	2
17	AGE-1004	Feeding sliding shaft	2
19	C1000H-2818A	Blade line plate 2	1
21	C1000H-2833	Rear vise base seal	1
23	C1000H-2835C	Fixed vise	1
25	C1000H-2843	Front movable vise	1
27	CGI-1074	Movable vise up seat	2
29	CGI-1076	Fixed vise cylinder seat	2
31	CGI-1077B	Feeding fixed vise	1
33	CGI-1078B	Movable vise	1
35	CGI-1023C	Rear fixed vise cover	2
37	CGI-1024	Front movable vise cover	1
39	PP-51143	Dust seal	4
41	PP-13289	Du bushing	4
43	CGI-1025	Rear movable cylinder cover	1
45	CGI-1059	Side cover (right)	1
47	CGI-1060	Side cover (left)	1
49	CGI-1074	Vise plate	8
51	PP-43473A	Cylinder	2
53	PP-43474A	Cylinder	1
55	PP-43474A	Cylinder	2
57	AGE-1024	Piston fitting	2
59	AGE-1075	Sliding shaft	4
61	PP-51191	Dust seal	8
63	PP-13225	Du bushing	8
65	CGI-1026-1	Weight balancer	1
67	CGI-1026-2	Weight balancer	1
69	CGI-1052	Vise side cover	1
71	SPM-2005A	Roller seat	12
73	PP-14143	Bearing	12

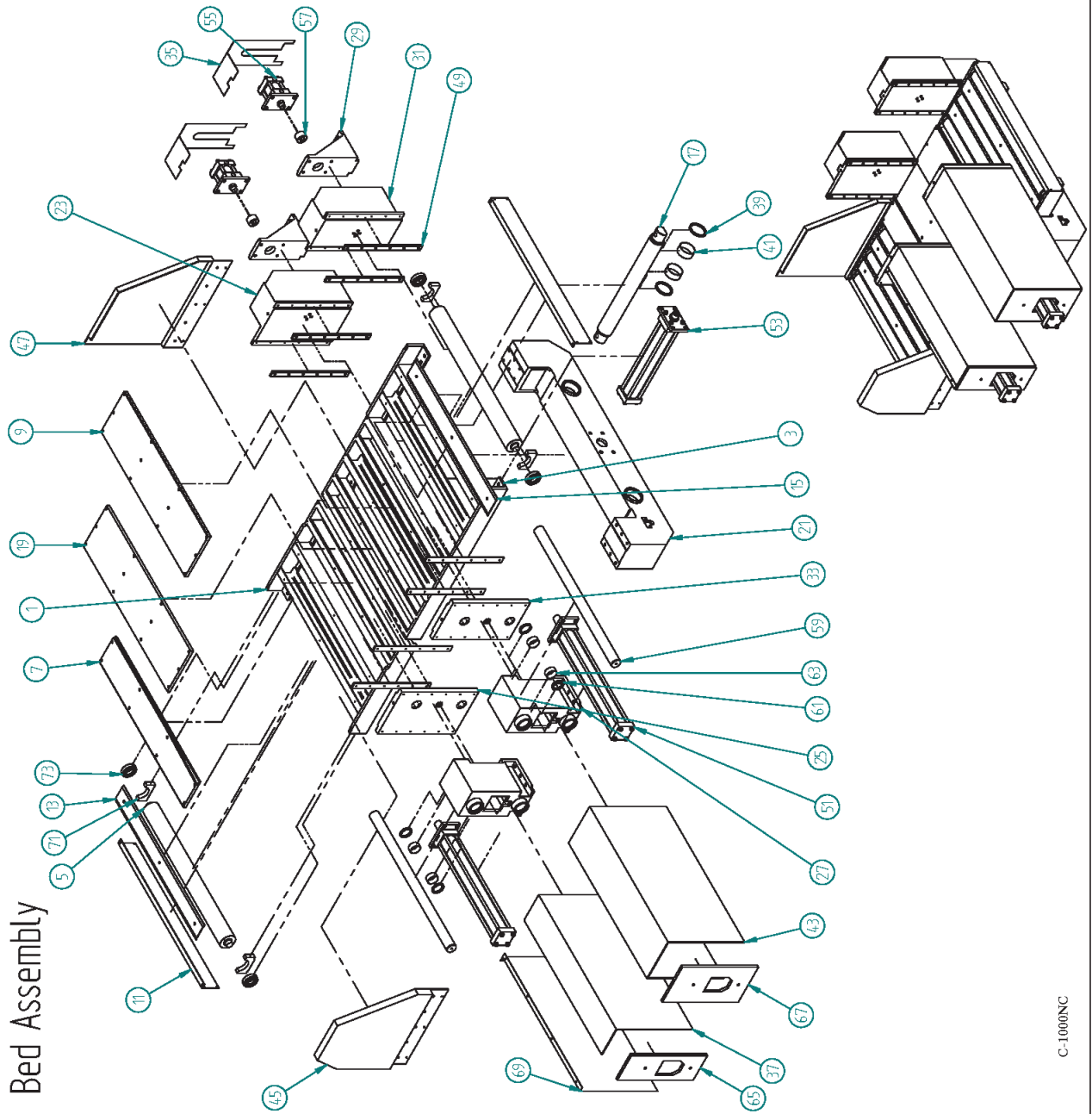

C-1000NC

# Saw bow assembly

NO.	PART NO.	PART NAME	QTY
1	SPM-3001A	Saw bow	1
3	Idle wheel assembly	Idle wheel assembly	1
5	SGJ-21010	Tension sliding assembly	1
7	SGJ-32800-1	Fixed cylinder assembly	1
9	SGJ-21030	Tensioner cylinder assembly	1
11	Motor assembly	Motor assembly	1
13	SPM-3020	Fixed guide arm	1
15	SPM-3021	Movable guide arm	1
17	PP-43405B	Cylinder	1
19	S8580-3127	Cylinder up ear	1
21	SDM-1027	Guide arm sliding plate	1
23	AGL-3010	Secondary sleeve	1
25	GL-3035A	Main sleeve	1
27	SDM-2093	Cylinder seat	1
29	SEL-30550	Left guide roller assembly	1
31	SEL-30560	Right guide roller assembly	1
33	GL-1037	Sleeve end cover	1
35	GL-1036	Sleeve end cover	1
37	PP-13359	Du bushing	2
39	PP-51135A	Oil seal	2
41	SPM-3010A	Driving wheel	1
43	SPM-3002	Idle wheel cover	1
45	SPM-3004	Driving wheel cover	1
47	PP-18805A	Blade	1
49	PP-51129	Oil seal	2
51	PP-13360	Du bushing	2
53	C1000H-3003	Up plate	1
55	C1000H-3004	Cover	1
57	SPM-1058	Saw arm fixed block	1
59	AGE-2083	Right angle junction panel	1
61	Wire brush assembly	Wire brush assembly	1

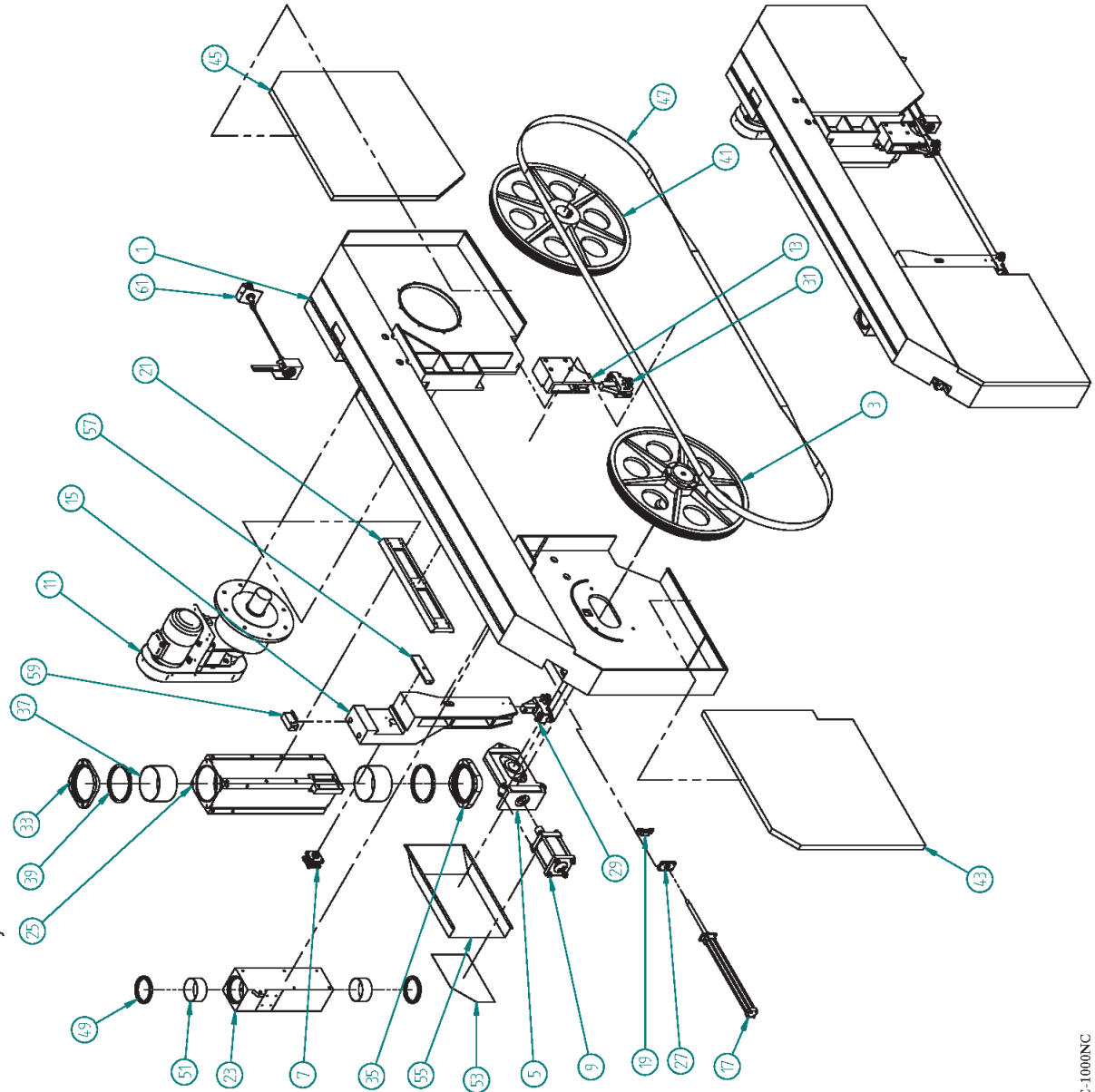

C-1000NC

# Saw bow assembly

NO.	PART NO.	PART NAME	QTY
1	SPM-3001A	Saw bow	1
3	Idle wheel assembly	Idle wheel assembly	1
5	SGJ-21010	Tension sliding assembly	1
7	SGJ-32800-1	Fixed cylinder assembly	1
9	SGJ-21030	Tensioner cylinder assembly	1
11	Motor assembly	Motor assembly	1
13	SPM-3020	Fixed guide arm	1
15	SPM-3021	Movable guide arm	1
17	PP-43405B	Cylinder	1
19	S8580-3127	Cylinder up ear	1
21	SDM-1027	Guide arm sliding plate	1
23	AGL-3010	Secondary sleeve	1
25	GL-3035A	Main sleeve	1
27	SDM-2093	Cylinder seat	1
29	SEL-30550	Left guide roller assembly	1
31	SEL-30560	Right guide roller assembly	1
33	GL-1037	Sleeve end cover	1
35	GL-1036	Sleeve end cover	1
37	PP-13359	Du bushing	2
39	PP-51135A	Oil seal	2
41	SPM-3010A	Driving wheel	1
43	SPM-3002	Idle wheel cover	1
45	SPM-3004	Driving wheel cover	1
47	PP-18805A	Blade	1
49	PP-51129	Oil seal	2
51	PP-13360	Du bushing	2
53	C1000H-3003	Up plate	1
55	C1000H-3004	Cover	1
57	SPM-1058	Saw arm fixed block	1
59	AGE-2083	Right angle junction panel	1
61	Wire brush assembly	Wire brush assembly	1

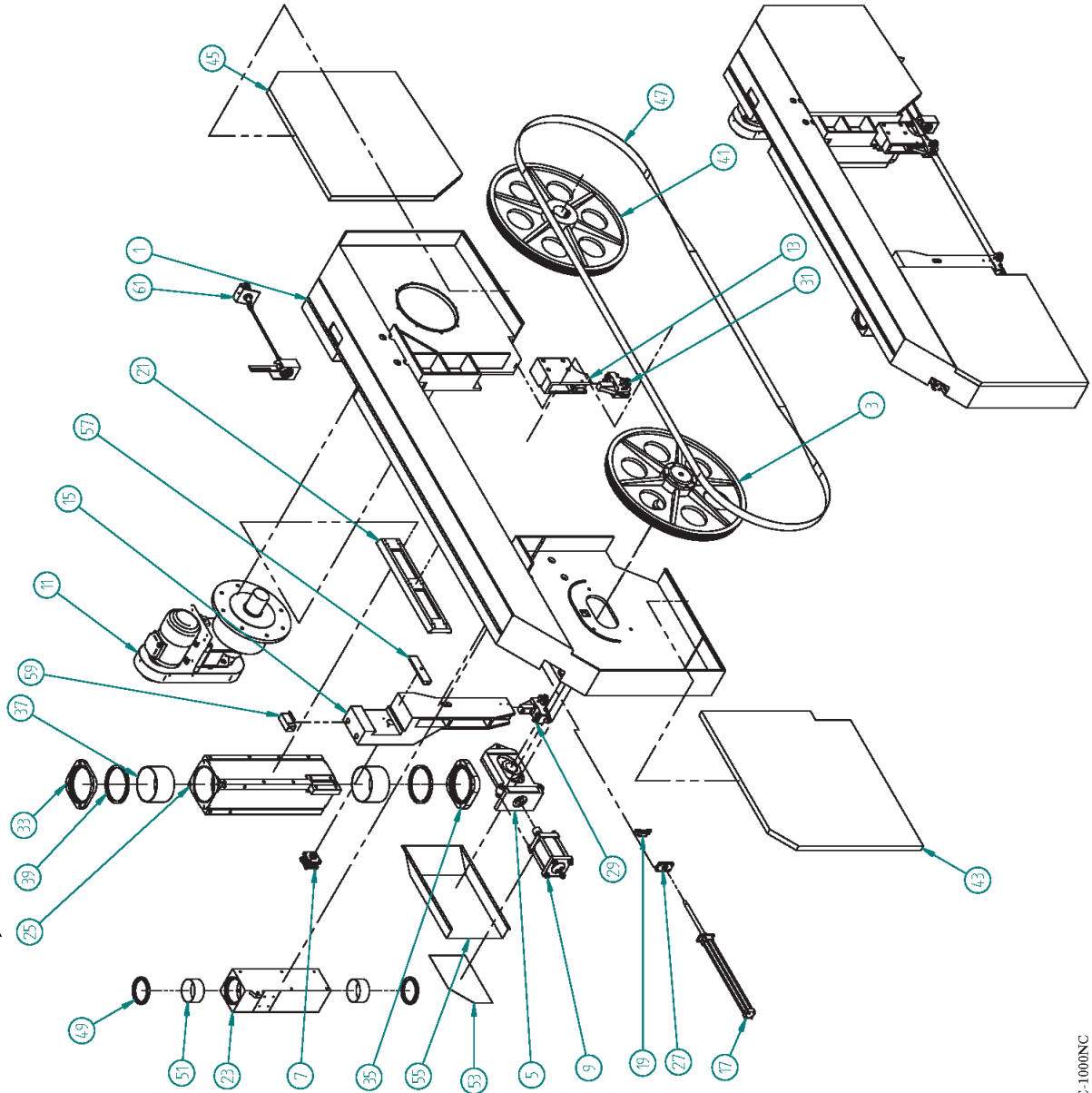

C-1000NC



# Idle wheel assembly

NO.	PART NO.	PART NAME	QYT
1	SPM-3012	Idle wheel	1
3	V1316-3033	Idle wheel shaft	1
5	SGJ-2008	Idle wheel shaft cover	1
7	SGJ-2011	Idle wheel fixer	1
9	PP-14630	BEARING 30220	2
11	PP-14920	Fixed nut AN20	1
13	PP-14970	Ring AW20	1
15	SPM-3014A	Washer	1
17	SPM-3014	Washer	1

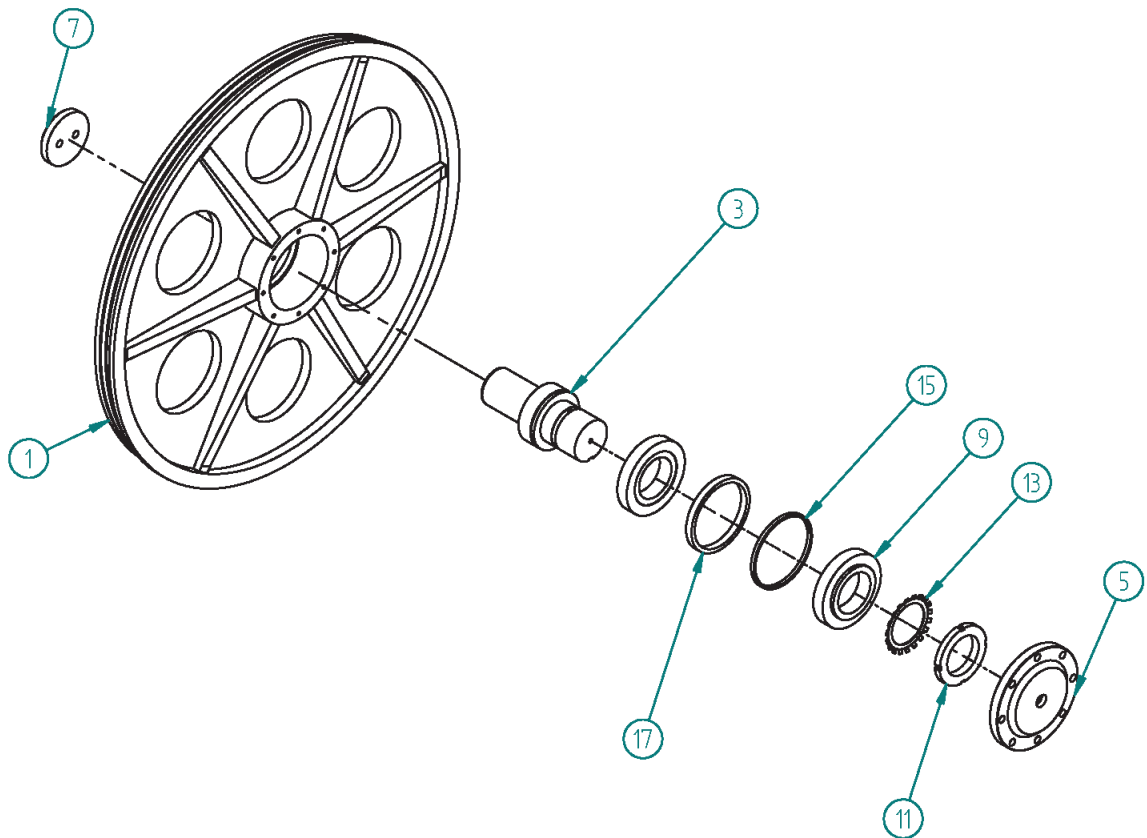

C-1000NC

# SGL-30550

## Left guide roller assembly

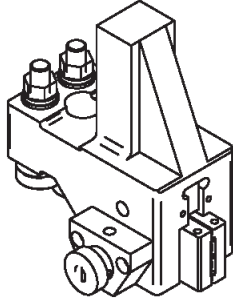

NO.	PART NO.	PART NAME	QTY
1	SGL-3055	Left guide wheel seat	1
3	SGL-3057	Left fixed insert	1
5	SGL-3058	Left movable insert	1
7	SGP-2019	Adjusting ring	1
9	SGP-2030	Cylinder	1
11	SGT-3040	PISTON	1
13	SGT-3041	Extended washer	1
15	S1010-3141	Guid wheel shaft 1	1
17	S1010-3143	Guid wheel shaft 2	1
19	PP-59101	O Ring P-26	1
21	PP-59072	Ring S15	1
23	PP-52089	Ring S17	2
25	PP-14267	Bearing 62032R	4
27	PP-13119	Bearing	1
29	AHA-0704A	Clamping seat	1
31	AGB-70410B	Pin	1
33	PQA-16	Nut	2
35	PPA-16	washer	2
37	PQA-16	Spring washer	2

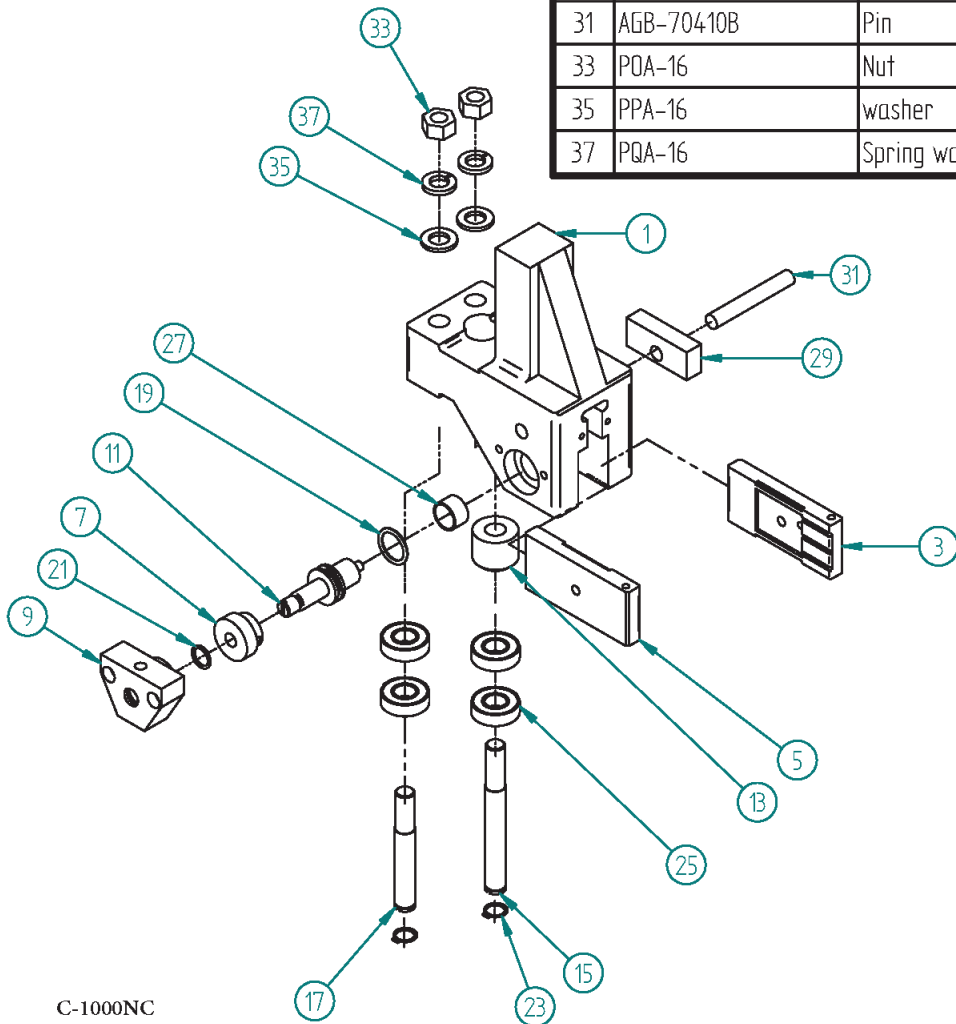

C-1000NC

SGL-3056  
Right guide roller assembly

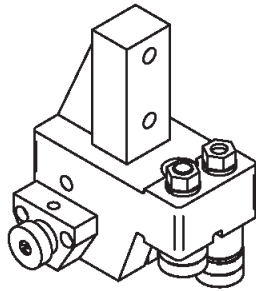

NO.	PART NO.	PART NAME	QYT
1	SGL-3056	Right guide wheel seat	1
3	AGB-70410A	Pin	1
5	AHA-0704A	Clamping seat	1
7	PP-13119	Bearing	1
9	PP-52089	Ring S17	2
11	PP-59072	O Ring P-16	1
13	PP-59101	O Ring P-26	1
15	SGL-3059	Right fixed insert	1
17	SGL-3060	Right movable insert	1
19	SGL-3061	Long leading guide shaft	1
21	SGL-3062	Short leading guide shaft	1
23	SGP-2019	Adjusting ring	1
25	SGP-2030	Cylinder	1
27	SGT-3040	Piston	1
29	SGT-3041	Extended washer	1
31	PP-14267	Bearing 62032R	4
33	PQA-16	Nut	2
35	PQA-16	Spring washer	2

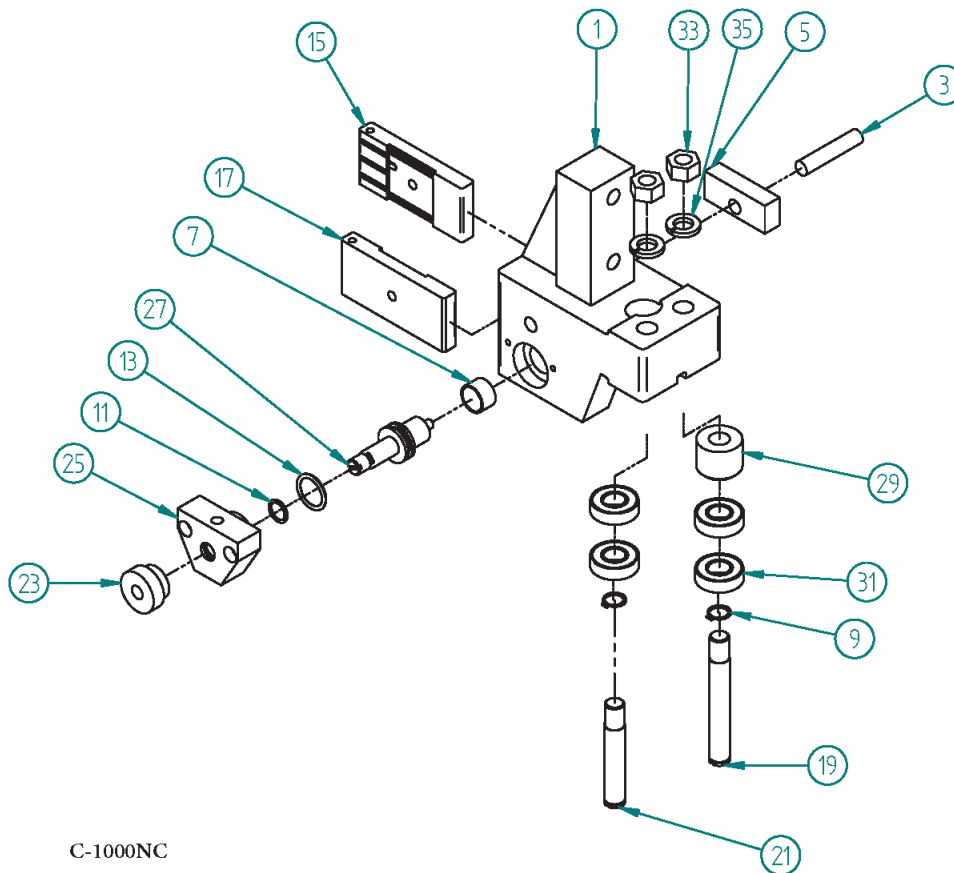

C-1000NC

# SGL-33010

NO.	PART NO.	PART NAME	QYT
1	SGL-3303A	Anti-vibration seat	1
3	SGL-3305	Shaft	1
5	SGL-3397	Shield	1
7	SGL-3302	Shaft	1
9	SGL-3301	Vibration roller	1
11	PP-91369	Pin $\Phi$ 10x55L	1
13	PP-58111	Ring R47	2
15	PP-57403	Spring TB-1625	1
17	PP-14507	Bearing 2204	1
19	AGB-3309	Bolt	1
21	AGB-3308	Rubber ring	1
23	AGB-3307	Grease cover	1
25	AGB-3306N	Spring seat	1
27	PP-14267	Bearing 62032R	5
29	PQA-10	Spring washer	1
31	PBA-10-16	Bolt	1
33	PPA-10	washer	1
35	PQA-16	Nut	1
37	PQA-16	Spring washer	1
39	PBA-5-12	bolt	1
41	PBA-6-50	bolt	1

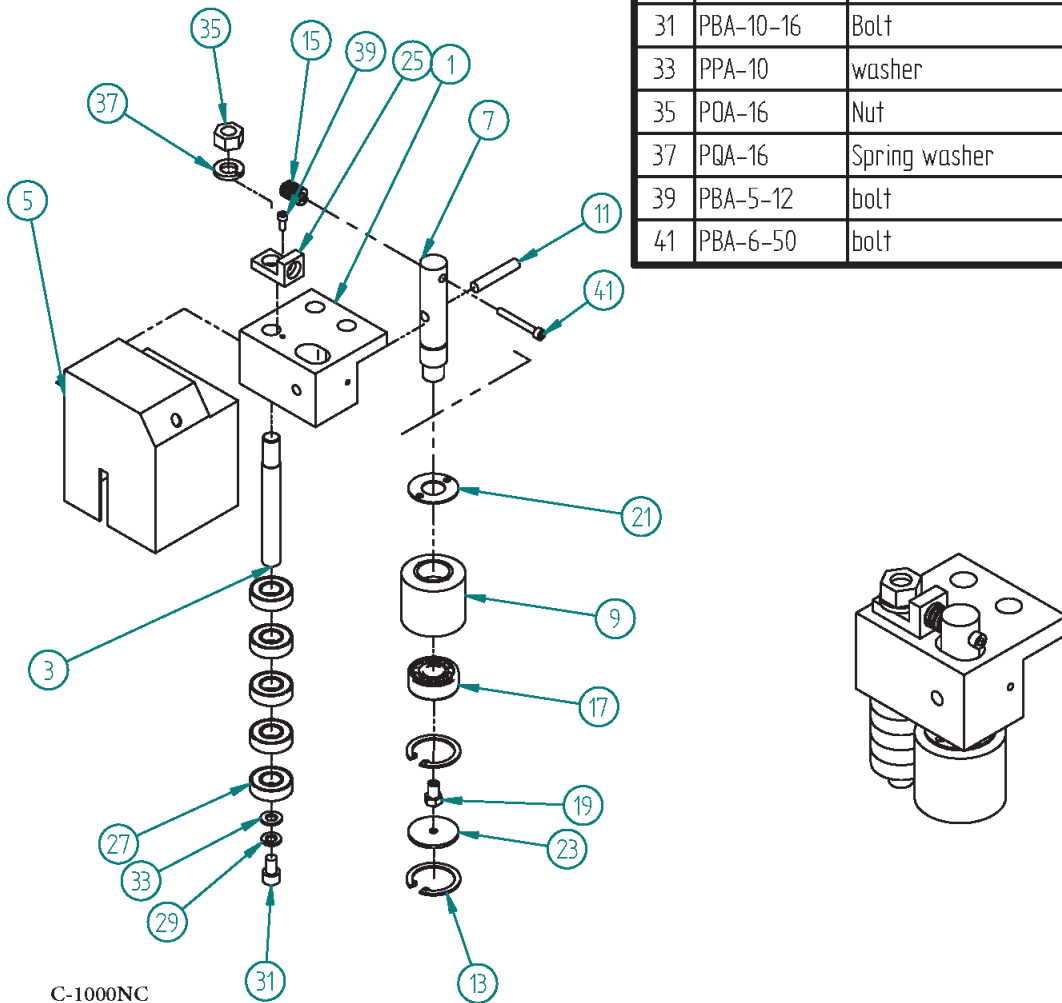

# Motor assembly

NO.	PART NO.	PART NAME	QYT
1	PP-16015	Planetary gearbox	1
3	PP-31172B	Motor	1
5	SGJ-2040	Motor fixed seat	1
7	SGJ-2041	Motor plate	1
9	SGJ-2042	Motor rotation shaft	1
11	SGJ-2043	Motor movable shaft	1
13	SGJ-2045	Motor pulley	1
15	SGJ-2046	Gearbox pulley	1
17	SGJ-2047-1	Pulley cover	1
19	SGJ-2047-2	Pulley cover	1
21	SGJ-2048	Pulley cover seat	2
23	SGJ-2049	Pulley stopper	2
25	SGN-2041	Adjusting screw rod	1
27	SGO-3038	Motor base accessory	1

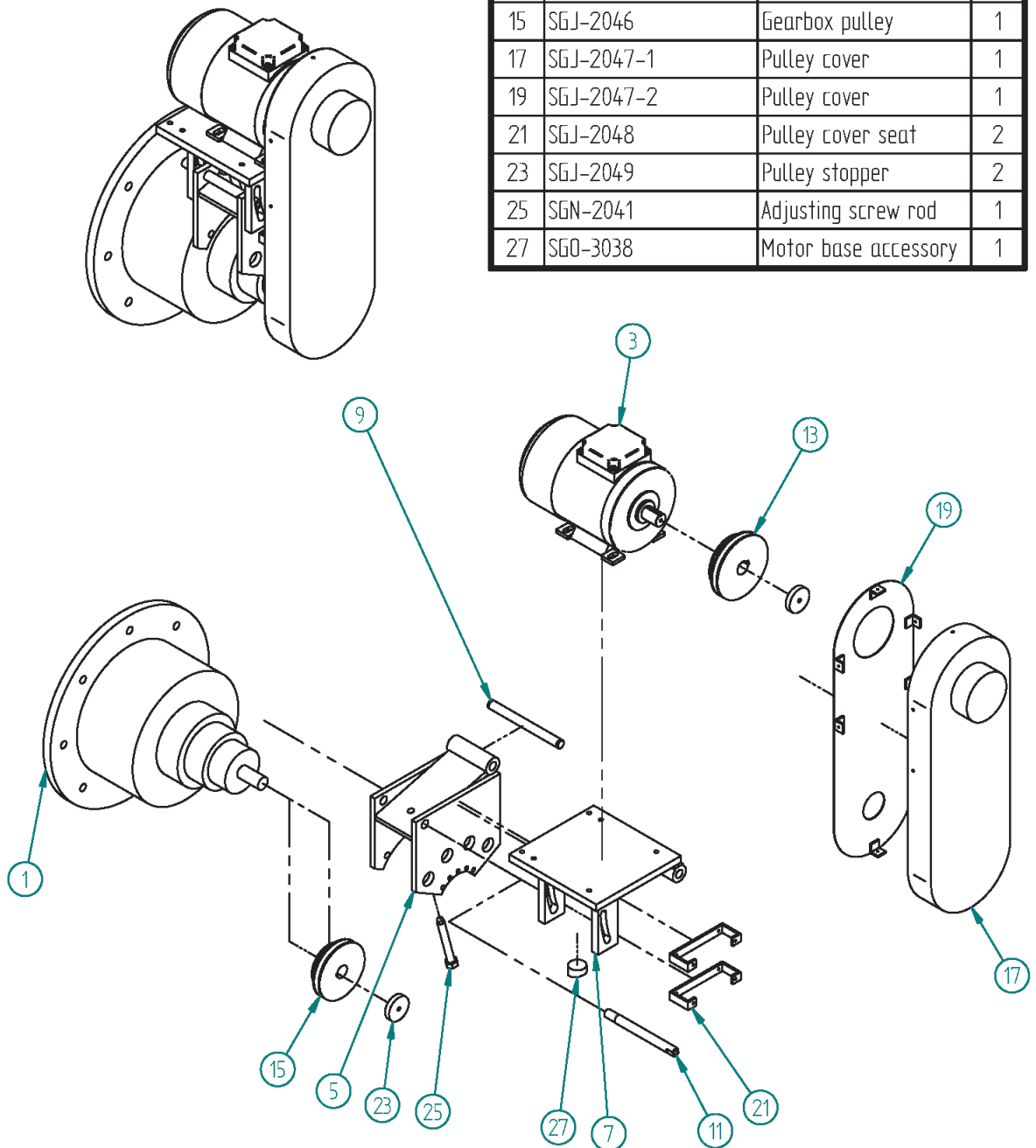

C-1000NC

# SGJ-21010

NO.	PART NO.	PART NAME	QTY
1	SGJ-2101	Tensioner sliding seat	1
3	SGJ-2102	Tensioner sliding plate	1
5	AGE-2044	Tensioner sliding pressure plate	2
7	PBA-12-30	Bolt	8
9	SGN-3034	Tensioner adjusting bolt	3

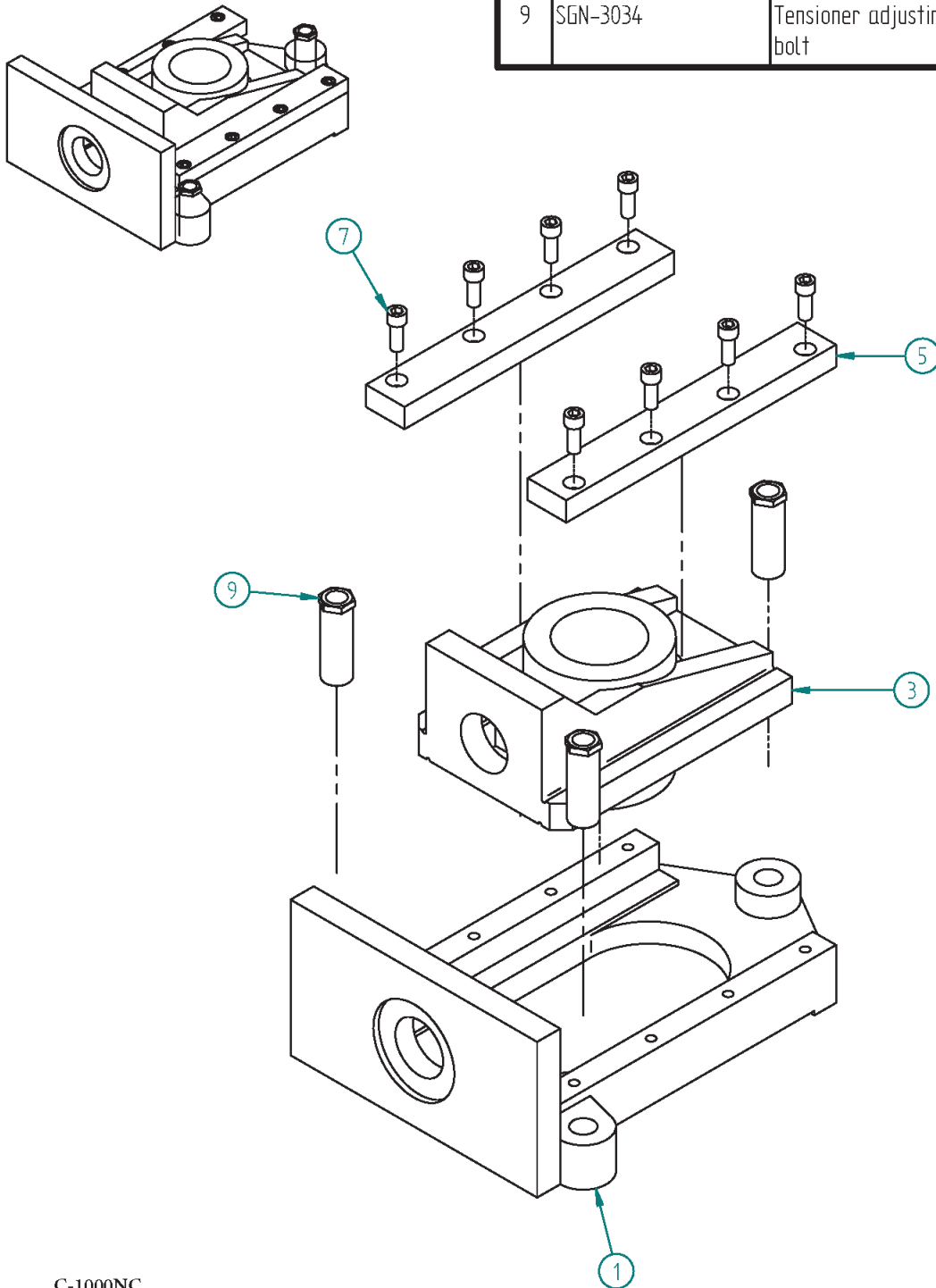

C-1000NC

# Wire brush assembly

NO.	PART NO.	PART NAME	QTY
1	PP-31640-1	Hydraulic motor	1
3	PP-58002	Wire brush	2
5	S1010-3244	Motor seat	1
7	SGJ-2052	Connecting sleeve	1
9	SGJ-2053	Connecting rod	1
11	SGJ-2059	Wire brush shaft	1
13	SGL-3016	Cover	1
15	PP-15010	Universal joint	2

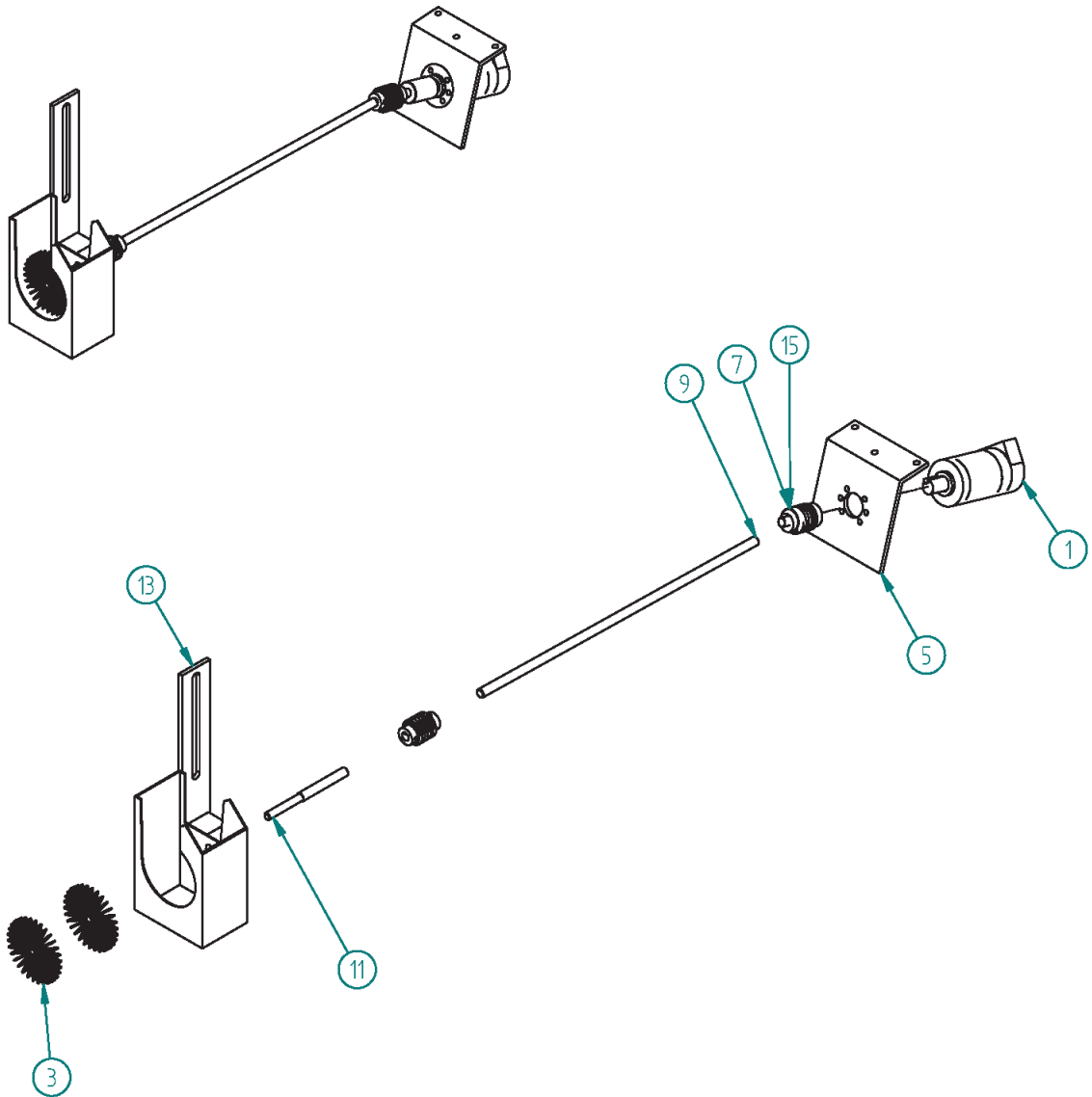

C-1000NC

C1000H-C001

NO.	PART NO.	PART NAME	QTY
1	C1000H-4001	Chip conveyor body	1
3	C1000H-4003A	Chip spiral	1
5	AGC-1061	Motor cover	1
7	AGC-1060A	Motor seat	1
9	AHA-2022B	Spiral shaft	1
11	AHB-2019A	Driving chain wheel 1	1
13	AHB-2019B	Driving chain wheel 2	1
15	AHB-2020B	Bearing seat	1
17	AHB-2023A	Chain wheel shaft	1
19	AHB-2026	Connecting plate	1
21	CGL-1039	Fixed bracket	1
23	CGL-1027	Chip collection board	1
25	PP-14003	Bearing 6202W	2
27	PP-31640-1	Bearing 6202W	1
29	PP-52097	Hydraulic motor	1
31	PP-58106	Ring S15	1
33	SGL-2118	Ring R35	1
35	SGL-2119	Back plate	1

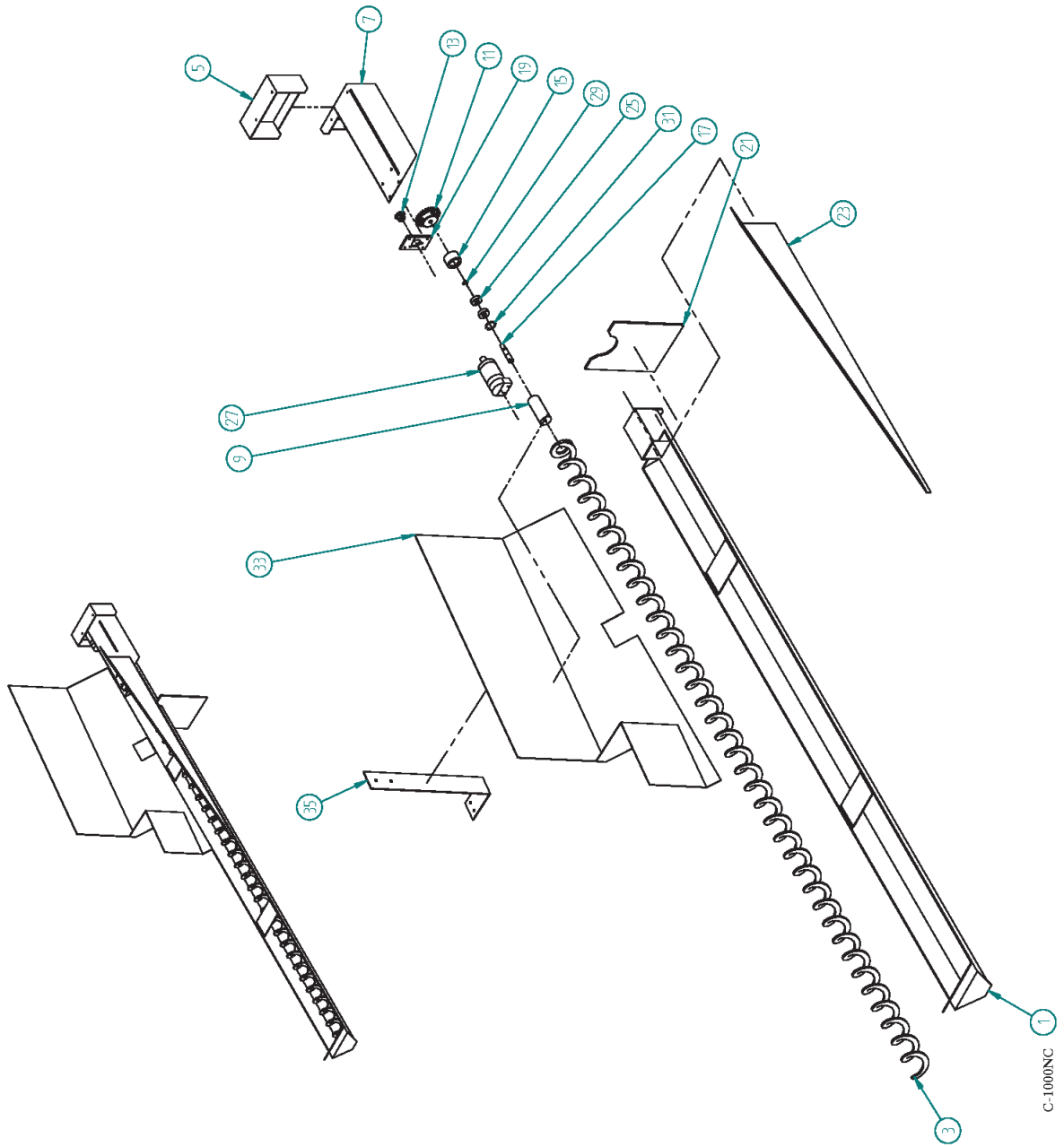

C-1000NC



# Control box assembly

NO.	PART NO.	PART NAME	QYT
1	NDD-1303	Base of control box	1
3	SVJ-3201B	Control box	1
5	C800H-1321	Control panel	1
7	C800H-1323	Ledger plate	1
9	C800H-1329	Fixed bracket	1
11	PP-43115	Flow valve FG0230	1

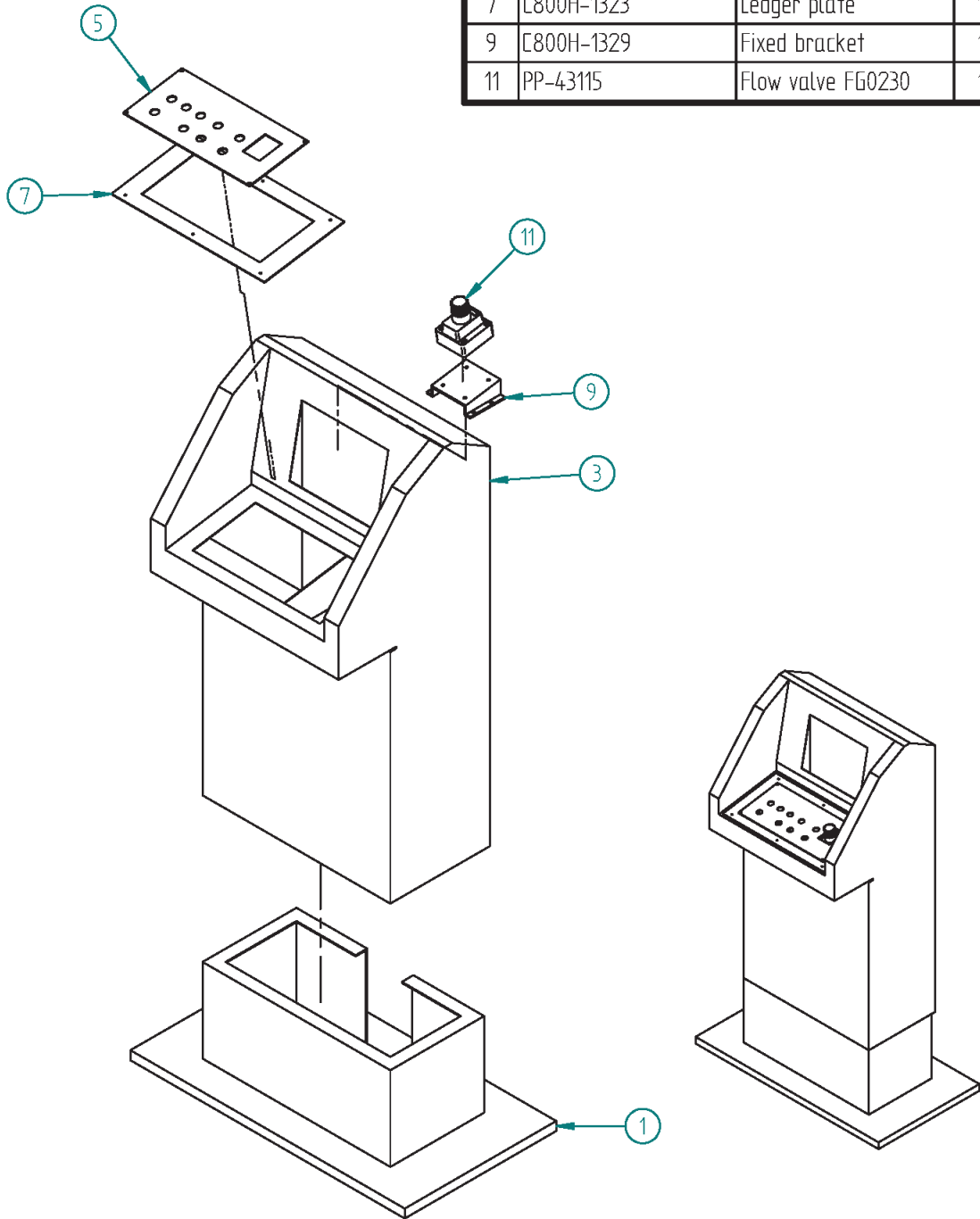

C-1000NC

# NGG-33010B

NO.	PART NO.	PART NAME	QYT
1	NGG-3305	Deviation detector cover	1
3	M3L-9-10	Spring	1
5	NGG-3301	Deviation detector body	1
7	NGG-3302D	Bottom plate	1
9	NGG-3303	Tungsten steel push rod	1
11	NGG-3304	Rotation shaft	1
13	NGG-3306	Tension sensor	1
15	NGG-3308	Fixed seat	1
17	NGG-3309	Detecting spring seat	1
19	PP-90419	Switch	1

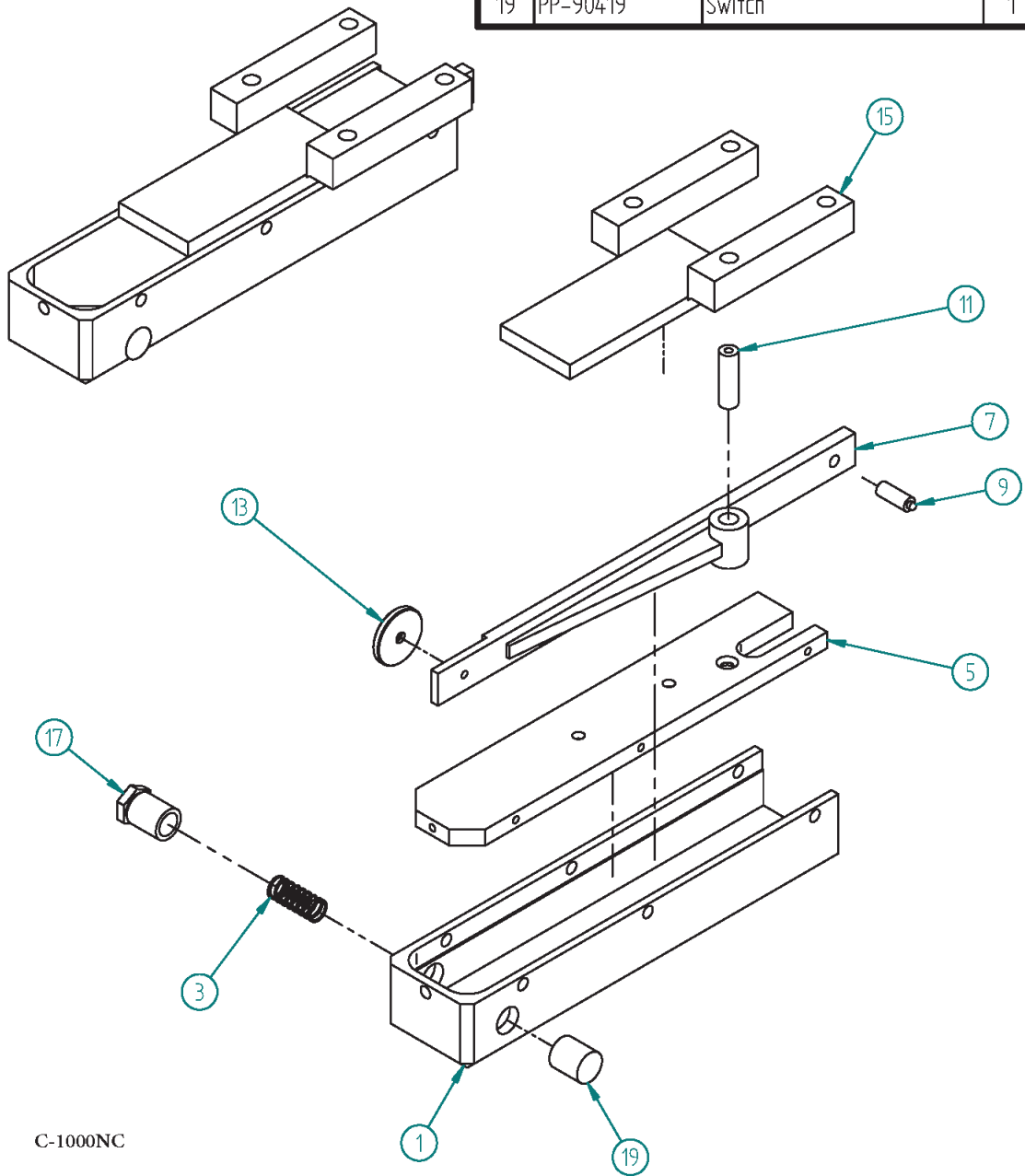

C-1000NC

# AGB-707270

NO.	PART NO.	PART NAME	QTY
1	AGB-70727	Filter body	1
3	AGB-70730	Filter core	1
5	O ring	O ring	1
7	AGB-70729	Spring	1
9	AGB-70728	Cover	1
11	PQA-6	spring washer	3
13	PBA-6-25	bolt	3

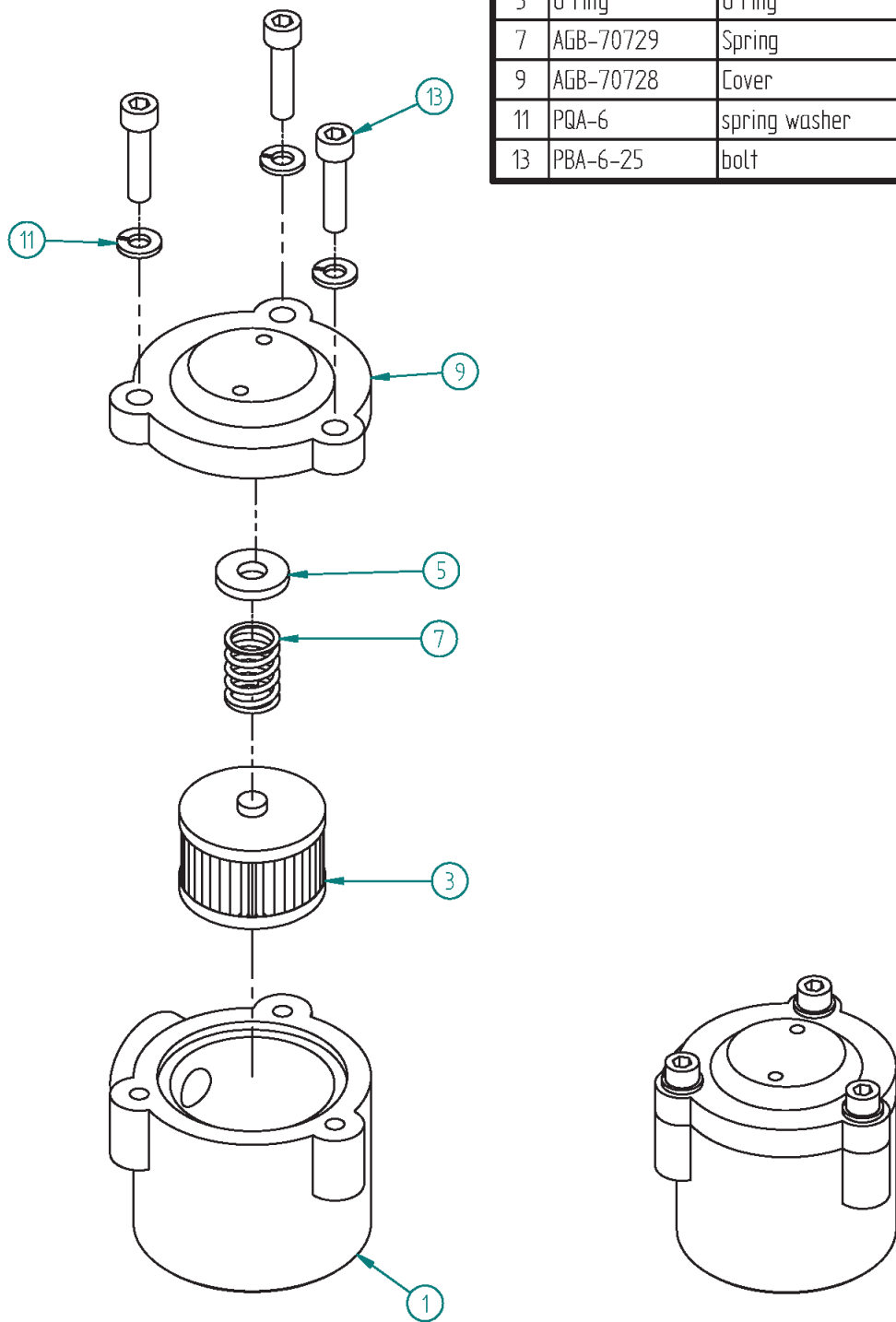

C-1000NC



Automatic bandsawing machines  
Semi-automatic bandsawing machines  
Miter bandsawing machines  
Workshop machines  
Vertical bandsaws  
Projects on measurement  
Roller tables  
Measuring & positioning systems  
Bandsaw blades en circular blades  
Lubricants for sawing  
Cleaning products

Please visit our website  
**[www.cosenedc.com](http://www.cosenedc.com)**